



US Micro Products
Electronic Products for the OEM

LCD PRODUCT SPECIFICATION

PART NUMBER:	USMPG-TQ16032C-TZWBH
DESCRIPTION:	160x32 Graphic LCD; STN Blue Display Mode; Transflective, Positive with White LED Sidelight and 6 O'Clock Viewing Direction.

ISSUE DATE	APPROVED BY (Customer Use Only)	CHECKED BY	PREPARED BY
PROPRIETARY NOTE:	THIS SPECIFICATION IS THE PROPERTY OF US MICRO PRODUCTS AND SHALL NOT BE REPRODUCED OR COPIED WITHOUT THE WRITTEN PERMISSION OF US MICRO PRODUCTS AND MUST BE RETURNED TO US MICRO PRODUCTS UPON ITS REQUEST.		

1.Features

1. Display format: 160*32 dots matrix graphic
2. FSTN, Positive Image , Transflective
3. Easy interface with 8-bit MPU
4. Low power consumption
5. LED side-light (white)
6. Viewing angle: 6 O'clock
7. Driving method: 1/32 duty, 1/6 bias
- 8 .LCD driver IC: AX6120DOA/AX6121DOA
9. Building in DC/DC

2.Outline dimension

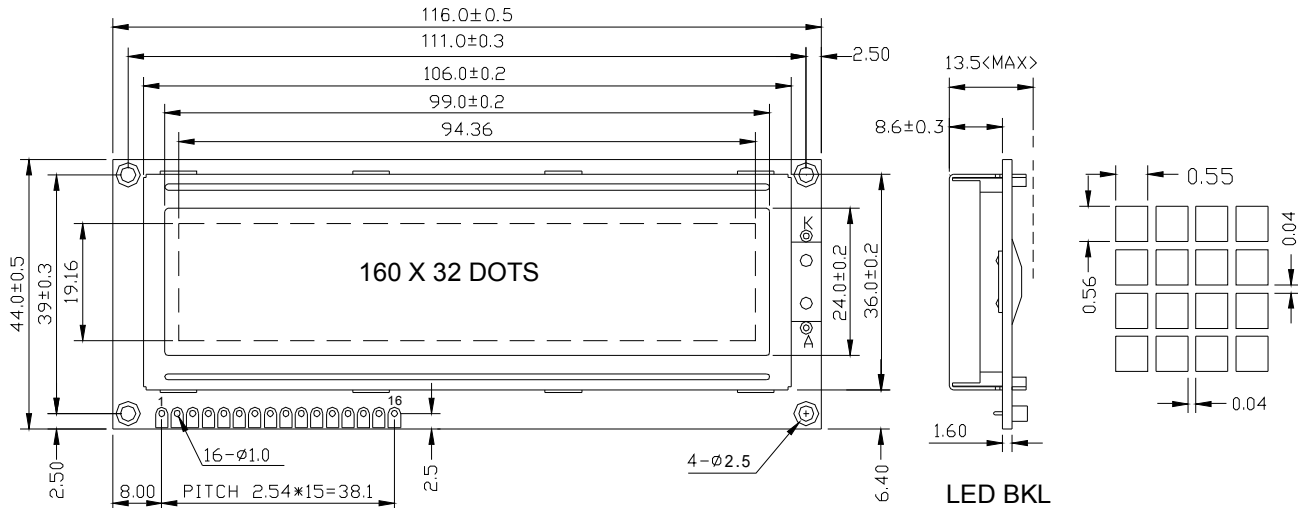

3.Absolute maximum ratings

Item	Symbol	Standard	Unit
Power voltage	$V_{DD}-V_{SS}$	0	7.0
Input voltage	V_{in}	VSS	VDD
Operating temperature range	Top	-20	+70
Storage temperature range	Tst	-30	+80

CONFIDENTIAL

4. Block diagram

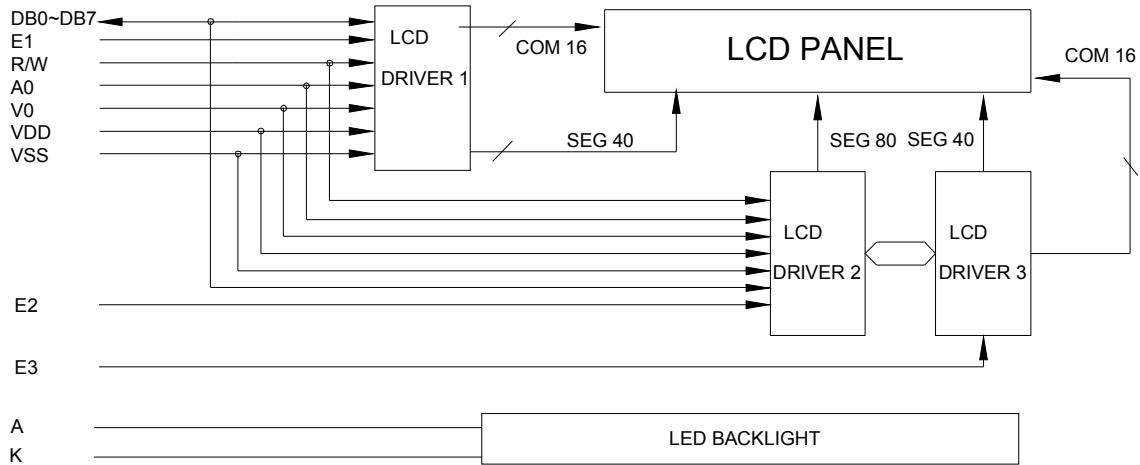

5. Interface pin description

Pin no.	Symbol	External connection	Function
1	A0	I	0: Instructions 1: data
2	E2	I	Enable signal for U2
3	E1	I	Enable signal for U1
4	R/W	I	Read/write select signal
5	V _{DD}	Power supply	Power supply for logic (+5V) for LCM
6	V _{SS}		Signal ground for LCM (GND)
7~14	DB0~DB7	I/O	Data bus [0~7] Bi-directional data bus
15	NC		
16	E3	I	Enable signal for U3

6. Optical characteristics

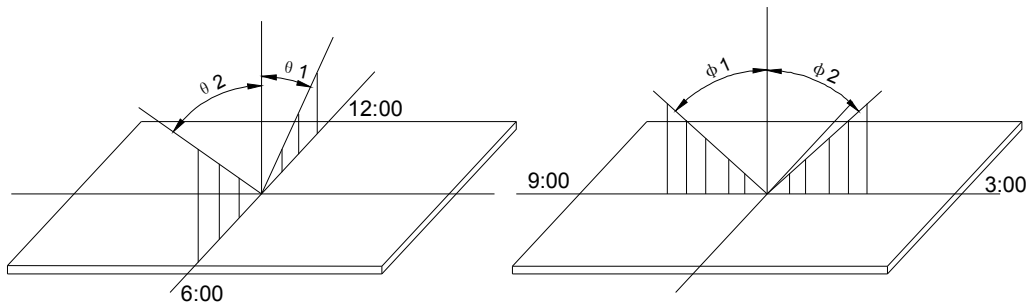

FSTN type display module (Ta=25°C, VDD=5.0V)

Item	Symbol	Condition	Min.	Typ.	Max.	Unit
Viewing angle	$\theta 1$	$C_r \geq 2$	-	45	-	deg
	$\theta 2$		-	60	-	
	$\Phi 1$		-	40	-	
	$\Phi 2$		-	40	-	
Contrast ratio	C_r	-	-	10	-	-
Response time (rise)	T_r	-	-	300	-	ms
Response time (fall)	T_r	-	-	300	-	

7. Electrical characteristics

CONFIDENTIAL

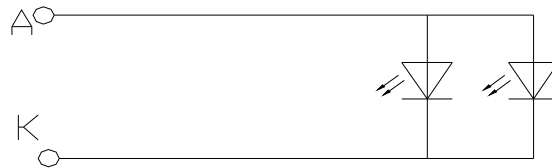
Backlight circuit diagram(light 2X1 Color :White)

LED ratings

Item	Symbol	Min	Typ.	Max	Unit
Forward Voltage	V_F	2.9	3.1	3.3	V
Forward current	I_F	-	20	30	mA
Power	P	-	-	99	mW
Peak wave length	λ_p	-	-	-	nm
Luminance	L_v	-	280	-	Cd/m^2

DC Electrical Characteristics

Parameter	Symbol	Conditions	Min.	Typ.	Max.	Unit
Supply voltage for LCD	$V_{DD}-V_0$	$T_a = 25^\circ C$	-	6.5	-	V
Input voltage	V_{DD}		4.8	5.0	5.3	
Supply current	I_{DD}	$T_a = 25^\circ C, V_{DD} = 5.0V$	-	2.0	3.5	mA
Input leakage current	I_{LKG}		-	-	5.0	μA
"H" level input voltage	V_H		2.2	-	V_{DD}	V
"L" level input voltage	V_L	Twice initial value or less	0	-	0.6	
"H" level output voltage	V_{OH}	LOH=-0.25mA	2.4	-	-	
"L" level output voltage	V_{OL}	LOH=1.6mA	-	-	0.4	
Backlight supply voltage	V_F		-	3.1	-	
Backlight supply current	I_F	$V = 3.1V$	-	20	-	mA

MPU bus read/write (68-family MPU)

Item	Symbol	Conditions	Min.	Max.	Unit
Address hold time	tAH6		10		ns
Address setup time	tAW6		20		
System cycle time	tCYC6		1000		
Data setup time	tDS6		80		
Data hold time	tDH6		10		
RD access time	tACC6	CL=100PF		90	
Output disable time	tCH6		10	60	
Enable pulse width	Read	tEW	100		
	Write		80		

MCU Bus Read /write 68MPU

CONFIDENTIAL

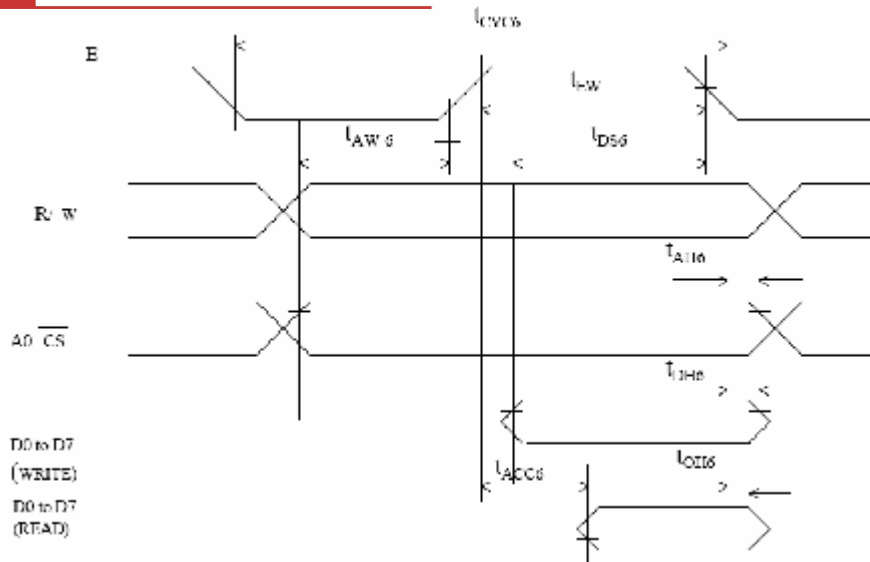

MPU bus read/write (80-family MPU)

Item	Symbol	Conditions	Min.	Max.	Unit
Address hold time	tAH8		10		ns
Address setup time	tAW8		20		
System cycle time	tCC		200		
Control pulse width	tCYC8		1000		
Data setup time	tDS8		80		
Data hold time	tDH8		10		
RD access time	tACC8	CL=100PF		90	
Output disable time	tCH8		10	60	

MCU Bus Read /write 80MPU

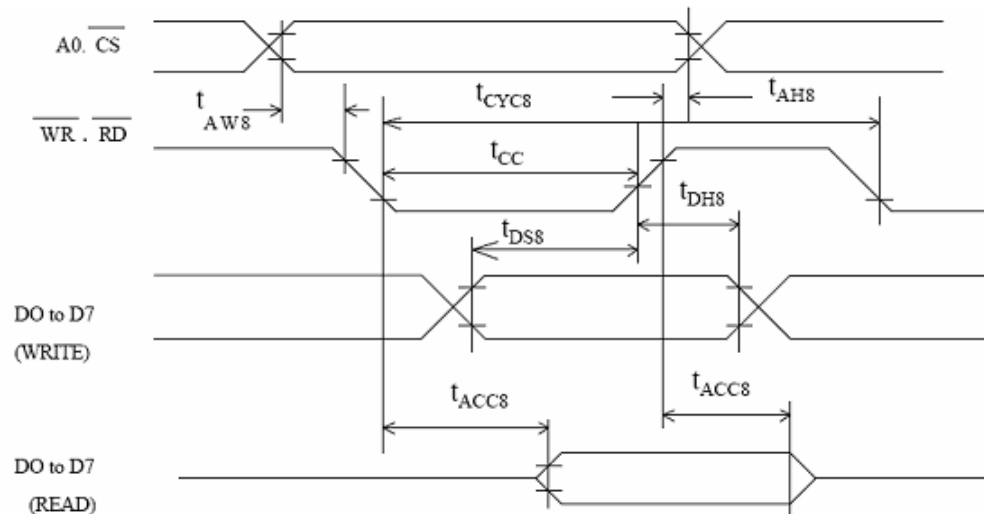

8. OPERATING PRINCIPLES & METHODS

BLOCK DESCRIPTION

System Bus

Data transfer

The AX6120 and AX6121 drivers use the A0.E (or RD) and R/W (or WR) signals to transfer data between the system MPU and internal registers. The combinations used are given in the table

CONFIDENTIAL

below.

In order to match the timing requirements of the MPU with those of the display data RAM and control registers all data is latched into and out of the driver. This introduces a one cycle delay between a read request for data and the arriving. For example when the MPU executes a read cycle to access display RAM the current contents of the latch are placed on the system data bus while the desired contents of the display RAM are moved into the latch.

This means that a dummy read cycle has to be executed at the start of every series of reads. See Figure 1. No dummy cycle is required at the start of a series of writes as data is transferred automatically from the input latch to its destination.

Common	68MPU	80MPU		Function
	R/W	RD	WR	
A0	1	0	1	Read display data
1	0	1	0	Write display data
0	1	0	1	Read status
0	0	1	0	Write to internal register (command)

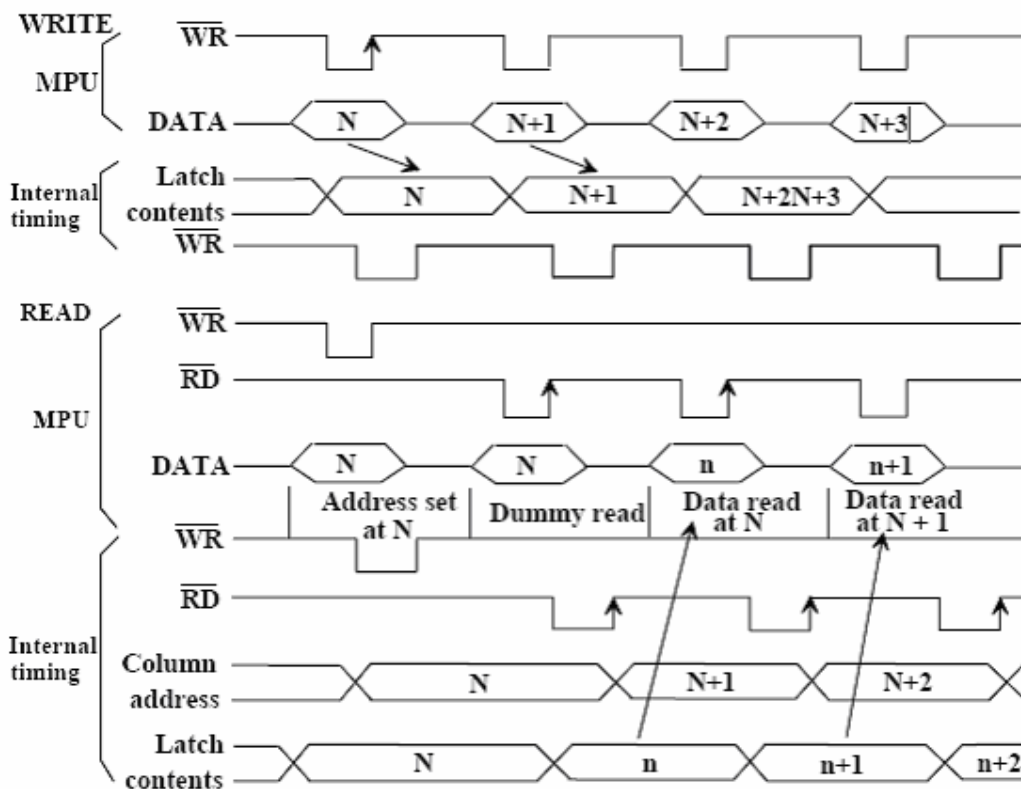

Figure 1 Bus Buffer Delay

Display Start Line and Line Count Registers

The contents of this register form a pointer to a line of data in display data RAM corresponding to the first line of the display (COM0), and are set by the Display Start Line command. See section 3. The contents of the display start line register are copied into the line count register at the start of every frame, that is on each edge of FR. The line count register is incremented by the CL clock once for every display line, thus generating a pointer to the current line of data, in display data RAM, being transferred to the segment driver circuits.

Column Address Counter

The column address counter is a 7-bit presettable counter that supplies the column address for

CONFIDENTIAL

MPU access to the display data RAM. See Figure 2. The counter is incremented by one every time the driver receives a Read or Write Display Data command. Addresses above 50H are invalid, and the counter will not increment past this value. The contents of the column address counter are set with the Set Column Address command.

Page Register

The page register is a 2-bit register that supplies the page address for MPU access to the display data RAM. See Figure 2. The contents of the page register are set by the Set Page Register command.

Display Data RAM

The display data RAM stores the LCD display data, on a 1-bit per pixel basis. The relationship between display data, display address and the display is shown in Figure 2.

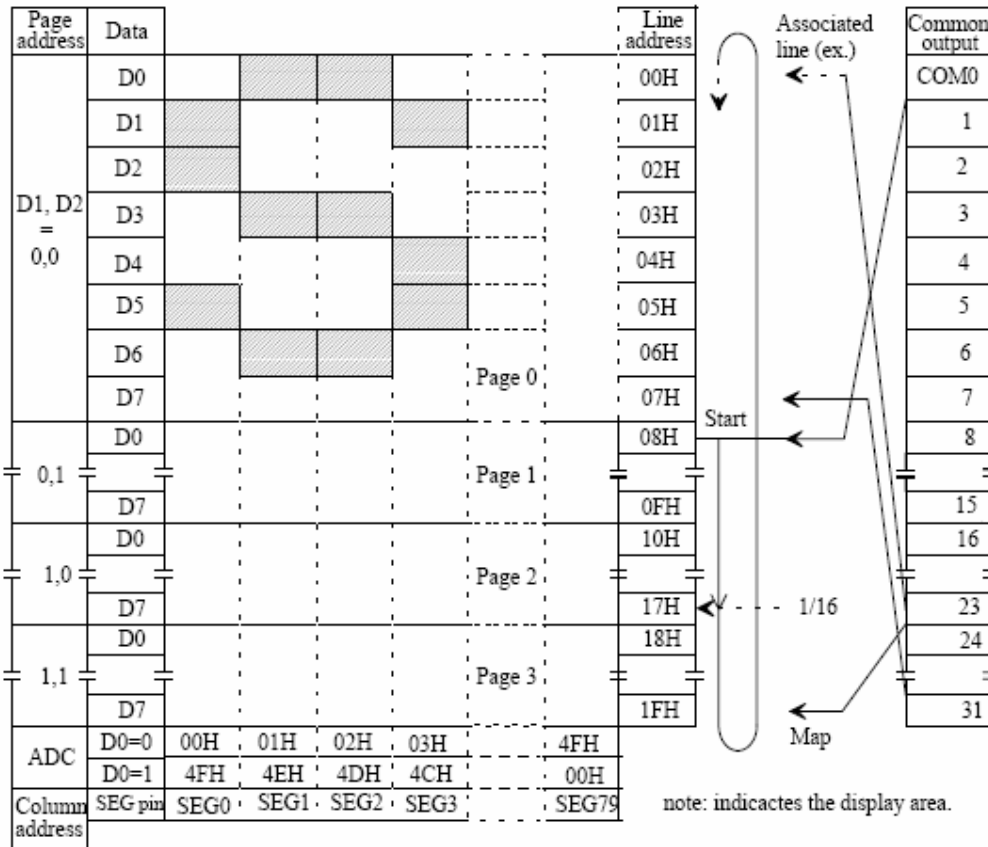

Figure 2 Display Data RAM Addressing

Common Timing Generator

This circuit generates common timing and frame, FR, signals from the basic clock, CL.

Display Data Latch Circuit

This latch stores one line of display data for use by the LCD driver interface circuitry. The output of

this latch is controlled by the Display ON/OFF and Static Drive ON/OFF commands

LCD Driver Circuit

The LCD driver circuitry generates the 80 4-level signals used to drive the LCD panel, using output from the display data latch and the common timing generator circuitry.

Display Timing Generator

This circuit generates the internal display timing signal using the basic clock, CL, and the frame signals, FR. FR is used to generate the dual frame AC-drive wave-form (type B drive) and to lock the line counter and common timing generator to the system frame rate.

CONFIDENTIAL

CL is used to lock the line counter to the system line scan rate. If a system uses both AX6120s and AX6121s they must have the same CL frequency rating.

Oscillator Circuit (AX6120F_{OA} Only)

The oscillator is a low power CR oscillator whose frequency of oscillation is determined by the value of the feedback resistor R_f. For details see section 6.1.

Reset Circuit

This circuit senses both the edge and the level of the signal at the RES pin and uses this information to

- reset the driver.
- configure the system bus interface.

9. Display Control Instruction

Parameter	A0	E	RW	D7	D6	D5	D4	D3	D2	D1	D0	Note
Display ON /OFF	0	1	0	1	0	1	0	1	1	1	0/1	Turns display on or off 1: ON ; 0 : OFF
Display start line	0	1	0	1	1	0	Display start address (0 to 31)				Specifies RAM line corresponding to top line of display	
Set page address	0	1	0	1	0	1	1	1	0	Page (0 to 3)		Sets display RAM page in page address register
Set column (segment) address	0	1	0	0	Column address (0 to 79)						Sets display RAM column address in column address register	
Read status	0	0	1	Bu sy	A D C	ON/ OFF	R E S E T	0	0	0	0	Reads the following status: BUSY 1: Busy 0: Ready ADC 1: CW output 0: CCW output ON/OFF 1: Display off 0: Display on RESET 1: Being reset 0: Normal
Write display data	1	1	0	Write data							Write data from data bus into display RAM	
Read display data	1	0	1	Read data							Read data from display RAM onto data bus	
Select ADC	0	1	0	1	0	1	0	0	0	0	0/1	0: CW output 1: CCW output
Static driver ON/OFF	0	1	0	1	0	1	0	0	1	0	0/1	Selects static driving operation. 1: static driver, 0: Normal driving
Select duty	0	1	0	1	0	1	0	1	0	0	0/1	Select LCD duty cycle 1: 1/32, 0: 1/16
Read-modify write	0	1	0	1	1	1	0	0	0	0	0	Read-modify-write ON
End	0	1	0	1	1	1	0	1	1	1	0	Read-modify-write OFF
Reset	0	1	0	1	1	1	0	0	0	1	0	Software reset

Above is the command table. The AX6120 series identifies a data bus using a combination of A0 and R/W (RD or WR signals. As the MPU translates a command in the internal timing only (independent from the external clock). Its speed is very high. The busy check is usually not

CONFIDENTIAL

required.

Display ON/OFF (AEH, AFH)

A0	E (RD)	R/W (/WR)	D7	D6	D5	D4	D3	D2	D1	D0
0	1	0	1	0	1	0	1	1	1	D

The command turns the display on and off
D=1: display ON D=0: display OFF

Display start line (C0H~DFH)

This command specifies the line address and indicates the display line that corresponds to COM0. the display area begins at the specified line address and continues the line address increment direction. This area having the number of lines of the specified display duty is displayed. If the line address is changed dynamically by this command the vertical smooth scrolling and paging can be used.

A0	E (RD)	R/W (/WR)	D7	D6	D5	D4	D3	D2	D1	D0
0	1	0	1	1	0	A4	A3	A2	A1	A0

This command loads the display start line register.

A4	A3	A2	A1	A0	Line address
0	0	0	0	0	0
0	0	0	0	1	1
/	/	/	/	/	/
1	1	1	1	1	31

Set page address (B8H~BBH)

This command specifies the page address that corresponds to the low address of the display data RAM when it is accessed by the MPU. Any bit of the display data RAM can be accessed when its page address and column address are specified. The display status is not changed even when the page address is changed.

A0	E (RD)	R/W (/WR)	D7	D6	D5	D4	D3	D2	D1	D0
0	1	0	1	0	1	1	1	0	A1	A0

This command loads the page address register.

A1	A0	Page
0	0	0

CONFIDENTIAL

0	1	1
1	0	2
1	1	3

Set column address (00H~4FH)

This command specifies a column address of the display data RAM. When the display data RAM is accessed by the MPU continuously, the column address is incremented by 1 each time it is accessed from the set address. Therefore, the MPU can access to data continuously. The column address stops to be incremented at address 80, and the page address is not changed continuously.

A0	E (RD)	R/W (/WR)	D7	D6	D5	D4	D3	D2	D1	D0
0	1	0	0	A6	A5	A4	A3	A2	A1	A0

This command loads the column address register.

A6	A5	A4	A3	A2	A1	A0	Line address
0	0	0	0	0	0	0	0
0	0	0	0	0	0	1	1
/	/	/	/	/	/	/	/
1	0	0	1	1	1	1	79

Read status

A0	E (RD)	R/W (/WR)	D7	D6	D5	D4	D3	D2	D1	D0
0	1	0	Busy	ADC	On/off	Reset	A3	A2	A1	A0

Reading the command I/O register (A0=0) yields system status information.

∅ The busy bit indicates whether the driver will accept a command or not.

Busy=1: the driver is currently executing a command or is resetting. No new command will be accepted.

Busy=0: the driver will accept a new command.

∅ The ADC bit indicates the way column addresses are assigned to segment drivers.

ADC=1 Normal. Column address n → segment driver n.

ADC=0 Inverted. Column address 79 u → segment driver u.

∅ The ON/OFF bit indicates the current status of the display.

It is the inverse of the polarity of the display ON/OFF command.

ON/OFF=1: display off

ON/OFF=0: display on

∅ The RESET bit indicates whether the driver is executing a hardware or software reset or if it is in normal operating mode.

Reset=1: currently executing reset command.

Reset=0: normal operation

Write display data

A0	E (RD)	R/W (/WR)	D7	D6	D5	D4	D3	D2	D1	D0
1	1	0	Write data							

Writes 8-bit of data into the display data RAM, at a location specified by the contents of the column address and page address registers and then increments the column address register by one.

Read display data

A0	E (RD)	R/W (/WR)	D7	D6	D5	D4	D3	D2	D1	D0
1	0	1	Read data							

Reads 8-bit of data from the data I/O latch, updates the contents of the I/O latch with display data from the display data RAM location specified by the contents of the column address and page address registers and then increments the column address register. After loading a new address into the column address register one dummy read is required before valid data is obtained.

Select ADC (A0H, A1H)

A0	E (RD)	R/W (/WR)	D7	D6	D5	D4	D3	D2	D1	D0
0	1	0	1	0	1	0	0	0	0	D

This command selects the relationship between display data RAM column addresses and segment drivers.

D=1: SEG0 ← column address 4FH,...(inverted).

D=0: SEG0 ← column address 00H,...(normal).

This command is provided to reduce restrictions on the placement of driver ICs and routing of traces during printed circuit board design.

Static drive ON/OFF (A4H, A5H)

A0	E (RD)	R/W (/WR)	D7	D6	D5	D4	D3	D2	D1	D0
0	1	0	1	0	1	0	0	1	0	D

Forces display on and all common outputs to be selected.

D=1:static drive on

D=0:static drive off

Select duty (A8H; A9H)

A0	E (RD)	R/W (/WR)	D7	D6	D5	D4	D3	D2	D1	D0
0	1	0	1	0	1	0	1	0	0	D

This command sets the duty cycle of the LCD drive and is only valid for the AX6120DAA and AX6122DAA. It is invalid for the AX6121DAA which performs passive operation. The duty cycle of the AX6121DAA is determined by the externally generated FR signal.

AX6120: D=1: 1/32 duty cycle; D=0: 1/16 duty cycle

AX6122: D=1: 1/16 duty cycle; D=0: 1/8 duty cycle

When using the AX6120DAA, AX6122DAA (having a built-in oscillator) and the AX6121DAA continuously, set the duty as follows:

		AX6121FOA
AX6120DAA	1/32	1/32
	1/16	1/16
AX6122DAA	1/16	1/32
	1/8	1/16

READ-MODIFY-WRITE (E0H)

A0	E (RD)	R/W (/WR)	D7	D6	D5	D4	D3	D2	D1	D0
0	1	0	1	1	1	0	0	0	0	0

This command defeats column address register auto-increment after data reads. The current contents of the column address register are saved. This mode remains active until an End command is received.

Operation sequence during cursor display

When the End command is entered, the column address is returned to the one used during input of read-modify-write command. This function can reduce the load of MPU when data change is repeated at a specific display area (such as cursor blinking).

*Any command other than data read or write can be used in the read-modify-write mode. However, the column address set command cannot be used.

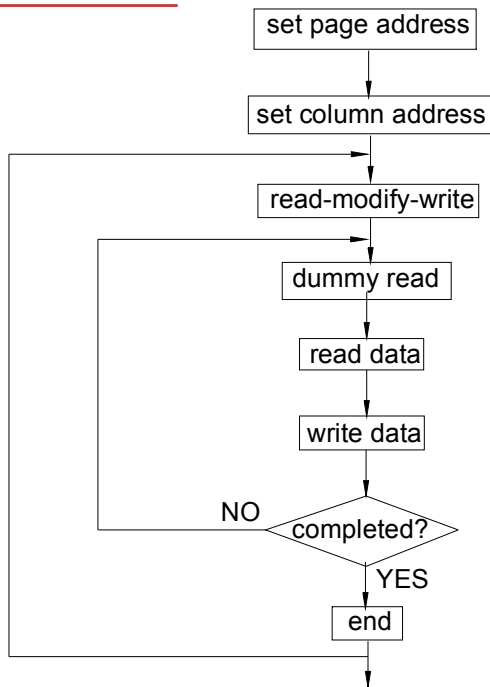

END (EEH)

A0	E (RD)	R/W (/WR)	D7	D6	D5	D4	D3	D2	D1	D0
0	1	0	1	1	1	0	1	1	1	0

This command cancels read-modify-write mode and restores the contents of the column address register to their value prior to the receipt of the read-modify-write command.

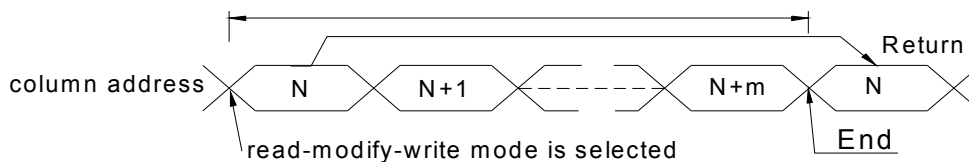

RESET (E2H)

A0	E (RD)	R/W (/WR)	D7	D6	D5	D4	D3	D2	D1	D0
0	1	0	1	1	1	0	1	1	1	0

This command clears

- The display starts line register.

- And set page address register to 3 page.

It does not affect the contents of the display data RAM.

When the power supply is turned on, a Reset signal is entered in the RES pin. The Reset command cannot be used instead of this Reset signal.

CONFIDENTIAL

10.QUALITY SPECIFICATIONS

10.1 Standard of the product appearance test

Manner of appearance test: The inspection should be performed in using 20W x 2 fluorescent lamps. Distance between LCM and fluorescent lamps should be 100 cm or more. Distance between LCM and inspector eyes should be 25 cm or more.

Viewing direction for inspection is 35° from vertical against LCM.

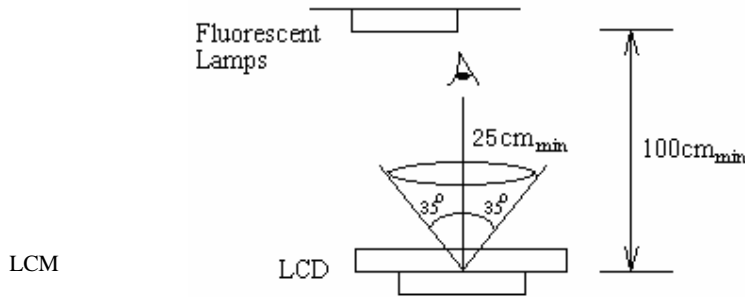

Definition of zone:

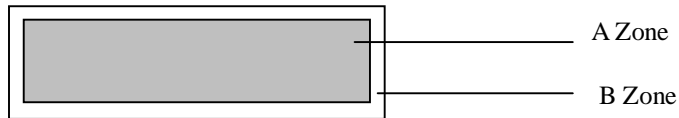

A Zone: Active display area (minimum viewing area).

B Zone: Non-active display area (outside viewing area).

10.2 Specification of quality assurance

AQL inspection standard

Sampling method: GB2828-87, Level II, single sampling

Defect classification **(Note: * is not including)**

Classify	Item	Note	AQL	
Major	Display state	Short or open circuit	1	0.65
		LC leakage		
		Flickering		
		No display		
	Wrong viewing direction	2		
	Contrast defect (dim, ghost)			
	Back-light	1,8		
Non-display	Flat cable or pin reverse	10		
	Wrong or missing component	11		
Minor	Display state	Background color deviation	2	1.0
		Black spot and dust	3	
		Line defect, Scratch	4	
		Rainbow	5	
		Chip	6	
		Pin hole	7	
		Protruded	12	
	Polarizer	Bubble and foreign material	3	
	Soldering	Poor connection	9	
	Wire	Poor connection	10	
	TAB	Position, Bonding strength	13	

CONFIDENTIAL

Note on defect classification

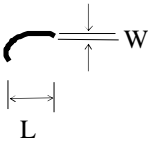
No.	Item	Criterion												
1	Short or open circuit	Not allow												
	LC leakage													
	Flickering													
	No display													
	Wrong viewing direction													
	Wrong Back-light													
2	Contrast defect	Refer to approval sample												
	Backgroundcolor deviation													
3	Point defect, Black spot, dust (including Polarizer)	 <table border="1" data-bbox="873 793 1279 1031"> <thead> <tr> <th>Point Size</th> <th>Acceptable Qty.</th> </tr> </thead> <tbody> <tr> <td>$\phi \leq 0.10$</td> <td>Disregard</td> </tr> <tr> <td>$0.10 < \phi \leq 0.15$</td> <td>2</td> </tr> <tr> <td>$0.15 < \phi \leq 0.25$</td> <td>1</td> </tr> <tr> <td>$\phi > 0.25$</td> <td>0</td> </tr> </tbody> </table> <p style="text-align: center;">Unit: Inch²</p>	Point Size	Acceptable Qty.	$\phi \leq 0.10$	Disregard	$0.10 < \phi \leq 0.15$	2	$0.15 < \phi \leq 0.25$	1	$\phi > 0.25$	0		
	Point Size		Acceptable Qty.											
$\phi \leq 0.10$	Disregard													
$0.10 < \phi \leq 0.15$	2													
$0.15 < \phi \leq 0.25$	1													
$\phi > 0.25$	0													
	$\phi = (X+Y)/2$													
4	Line defect, Scratch	 <table border="1" data-bbox="808 1245 1317 1409"> <thead> <tr> <th colspan="2">Line</th> <th rowspan="2">Acceptable Qty.</th> </tr> <tr> <th>L</th> <th>W</th> </tr> </thead> <tbody> <tr> <td>---</td> <td>$0.05 > W$</td> <td rowspan="3">Disregard</td> </tr> <tr> <td>$3.0 > L$</td> <td>$0.1 > W > 0.05$</td> </tr> <tr> <td>$2.0 > L$</td> <td>$0.15 \geq W > 0.1$</td> </tr> </tbody> </table> <p style="text-align: center;">Unit: mm</p>	Line		Acceptable Qty.	L	W	---	$0.05 > W$	Disregard	$3.0 > L$	$0.1 > W > 0.05$	$2.0 > L$	$0.15 \geq W > 0.1$
	Line		Acceptable Qty.											
L	W													
---	$0.05 > W$	Disregard												
$3.0 > L$	$0.1 > W > 0.05$													
$2.0 > L$	$0.15 \geq W > 0.1$													
5	Rainbow	Not more than two color changes across the viewing area.												

CONFIDENTIAL

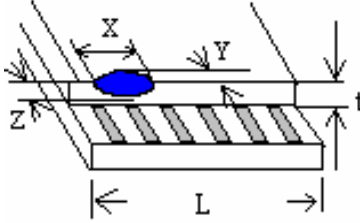
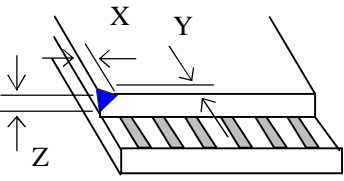
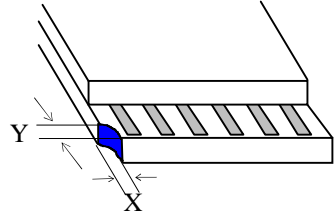
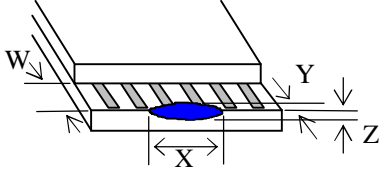
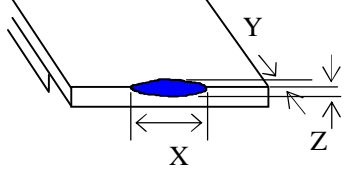
No	Item	Criterion																																	
6	<p>Chip</p> <p>Remark:</p> <p>X: Length direction</p> <p>Y: Short direction</p> <p>Z: Thickness direction</p> <p>t: Glass thickness</p> <p>W: Terminal Width</p> <p>L: Glass length</p>	 <p>Acceptable criterion</p> <table border="1" data-bbox="933 304 1299 378"> <thead> <tr> <th>X</th> <th>Y</th> <th>Z</th> </tr> </thead> <tbody> <tr> <td>$< L/8$</td> <td>0.5mm</td> <td>$\leq t/2$</td> </tr> </tbody> </table>  <p>Acceptable criterion</p> <table border="1" data-bbox="925 598 1307 672"> <thead> <tr> <th>X</th> <th>Y</th> <th>Z</th> </tr> </thead> <tbody> <tr> <td>≤ 2</td> <td>0.5mm</td> <td>$\leq t$</td> </tr> </tbody> </table>  <p>Acceptable criterion</p> <table border="1" data-bbox="941 871 1307 976"> <thead> <tr> <th>X</th> <th>Y</th> <th>Z</th> </tr> </thead> <tbody> <tr> <td>≤ 3</td> <td>≤ 2</td> <td>$\leq t$</td> </tr> <tr> <td colspan="2">shall not reach to ITO</td> <td></td> </tr> </tbody> </table>  <p>Acceptable criterion</p> <table border="1" data-bbox="933 1228 1307 1302"> <thead> <tr> <th>X</th> <th>Y</th> <th>Z</th> </tr> </thead> <tbody> <tr> <td>Disregard</td> <td>≤ 0.2</td> <td>$\leq t$</td> </tr> </tbody> </table>  <p>Acceptable criterion</p> <table border="1" data-bbox="933 1491 1274 1564"> <thead> <tr> <th>X</th> <th>Y</th> <th>Z</th> </tr> </thead> <tbody> <tr> <td>≤ 5</td> <td>≤ 2</td> <td>$\leq t/3$</td> </tr> </tbody> </table>	X	Y	Z	$< L/8$	0.5mm	$\leq t/2$	X	Y	Z	≤ 2	0.5mm	$\leq t$	X	Y	Z	≤ 3	≤ 2	$\leq t$	shall not reach to ITO			X	Y	Z	Disregard	≤ 0.2	$\leq t$	X	Y	Z	≤ 5	≤ 2	$\leq t/3$
X	Y	Z																																	
$< L/8$	0.5mm	$\leq t/2$																																	
X	Y	Z																																	
≤ 2	0.5mm	$\leq t$																																	
X	Y	Z																																	
≤ 3	≤ 2	$\leq t$																																	
shall not reach to ITO																																			
X	Y	Z																																	
Disregard	≤ 0.2	$\leq t$																																	
X	Y	Z																																	
≤ 5	≤ 2	$\leq t/3$																																	

CONFIDENTIAL

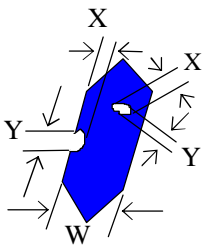
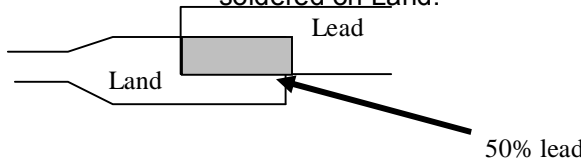
No.	Item	Criterion								
7	Segment pattern W = Segment width $\phi = (X+Y)/2$	<p>(1) Pin hole $\phi < 0.10\text{mm}$ is acceptable.</p>  <table border="1" data-bbox="868 409 1295 567"> <thead> <tr> <th>Point Size</th> <th>Acceptable Qty</th> </tr> </thead> <tbody> <tr> <td>$\phi \leq 1/4W$</td> <td>Disregard</td> </tr> <tr> <td>$1/4W < \phi \leq 1/2W$</td> <td>1</td> </tr> <tr> <td>$\phi > 1/2W$</td> <td>0</td> </tr> </tbody> </table> <p style="text-align: right;">Unit: mm</p>	Point Size	Acceptable Qty	$\phi \leq 1/4W$	Disregard	$1/4W < \phi \leq 1/2W$	1	$\phi > 1/2W$	0
Point Size	Acceptable Qty									
$\phi \leq 1/4W$	Disregard									
$1/4W < \phi \leq 1/2W$	1									
$\phi > 1/2W$	0									
8	Back-light	<p>(1) The color of backlight should correspond its specification.</p> <p>(2) Not allow flickering</p>								
9	Soldering	<p>(1) Not allow heavy dirty and solder ball on PCB. (The size of dirty refer to point and dust defect)</p> <p>(2) Over 50% of lead should be soldered on Land.</p> 								
10	Wire	<p>(1) Copper wire should not be rusted</p> <p>(2) Not allow crack on copper wire connection.</p> <p>(3) Not allow reversing the position of the flat cable.</p> <p>(4) Not allow exposed copper wire inside the flat cable.</p>								
11*	PCB	<p>(1) Not allow screw rust or damage.</p> <p>(2) Not allow missing or wrong putting of component.</p>								

CONFIDENTIAL

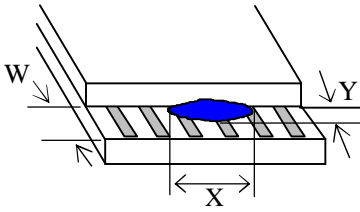
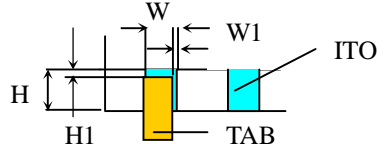
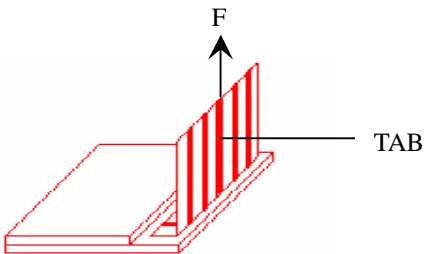
No	Item	Criterion
12	Protruded W: Terminal Width	 <p>Acceptable criteria: $Y \leq 0.4$</p>
13	TAB	<p>1. Position</p>  <div style="border: 1px solid black; padding: 5px; width: fit-content; margin-left: auto; margin-right: auto;"> $W1 \leq 1/3W$ $H1 \leq 1/3H$ </div> <p>2. TAB bonding strength test</p>  <p>$P (=F/TAB \text{ bonding width}) \geq 650\text{gf/cm}$, (speed rate: 1mm/min) 5pcs per SOA (shipment)</p>
14	Total no. of acceptable Defect	<p>A. Zone</p> <p>Maximum 2 minor non-conformities per one unit. Defect distance: each point to be separated over 10mm</p> <p>B. Zone</p> <p>It is acceptable when it is no trouble for quality and assembly in customer's end product.</p>

10.3 Reliability of LCM

Reliability test condition:

Item	Condition	Time (hrs)	Assessment
High temp. Storage	80°C	48	No abnormalities in functions and appearance
High temp. Operating	70°C	48	
Low temp. Storage	-30°C	48	
Low temp. Operating	-20°C	48	
Humidity	40°C/ 90%RH	48	
Temp. Cycle	0°C ← 25°C → 50°C (30 min ← 5 min → 30min)	10cycles	

Recovery time should be 24 hours minimum. Moreover, functions, performance and appearance shall be free from remarkable deterioration within 50,000 hours under ordinary operating and storage conditions room temperature (20±8°C), normal humidity (below 65% RH), and in the area not exposed to direct sun light.

10.4 Precaution for using LCD/LCM

LCD/LCM is assembled and adjusted with a high degree of precision. Do not attempt to make any alteration or modification. The followings should be noted.

General Precautions:

1. LCD panel is made of glass. Avoid excessive mechanical shock or applying strong pressure onto the surface of display area.
2. The polarizer used on the display surface is easily scratched and damaged. Extreme care should be taken when handling. To clean dust or dirt off the display surface, wipe gently with cotton, or other soft material soaked with isopropyl alcohol, ethyl alcohol or trichlorotrifluoroethane, do not use water, ketone or aromatics and never scrub hard.
3. Do not tamper in any way with the tabs on the metal frame.
4. Do not make any modification on the PCB without consulting USMP
5. When mounting a LCM, make sure that the PCB is not under any stress such as bending or twisting. Elastomer contacts are very delicate and missing pixels could result from slight dislocation of any of the elements.
6. Avoid pressing on the metal bezel, otherwise the elastomer connector could be deformed and lose contact, resulting in missing pixels and also cause rainbow on the display.
7. Be careful not to touch or swallow liquid crystal that might leak from a damaged cell. Any liquid crystal adheres to skin or clothes, wash it off immediately with soap and water.

Static Electricity Precautions:

1. CMOS-LSI is used for the module circuit; therefore operators should be grounded whenever he/she comes into contact with the module.
2. Do not touch any of the conductive parts such as the LSI pads; the copper leads on the PCB and the interface terminals with any parts of the human body.
3. Do not touch the connection terminals of the display with bare hand; it will cause disconnection or

CONFIDENTIAL

- defective insulation of terminals.
4. The modules should be kept in anti-static bags or other containers resistant to static for storage.
 5. Only properly grounded soldering irons should be used.
 6. If an electric screwdriver is used, it should be grounded and shielded to prevent sparks.
 7. The normal static prevention measures should be observed for work clothes and working benches.
 8. Since dry air is inductive to static, a relative humidity of 50-60% is recommended.

Soldering Precautions:

1. Soldering should be performed only on the I/O terminals.
2. Use soldering irons with proper grounding and no leakage.
3. Soldering temperature: $280^{\circ}\text{C}\pm 10^{\circ}\text{C}$
4. Soldering time: 3 to 4 second.
5. Use eutectic solder with resin flux filling.
6. If flux is used, the LCD surface should be protected to avoid spattering flux.
7. Flux residue should be removed.

Operation Precautions:

1. The viewing angle can be adjusted by varying the LCD driving voltage V_o .
2. Since applied DC voltage causes electro-chemical reactions, which deteriorate the display, the applied pulse waveform should be a symmetric waveform such that no DC component remains. Be sure to use the specified operating voltage.
3. Driving voltage should be kept within specified range; excess voltage will shorten display life.
4. Response time increases with decrease in temperature.
5. Display color may be affected at temperatures above its operational range.
6. Keep the temperature within the specified range usage and storage. Excessive temperature and humidity could cause polarization degradation, polarizer peel-off or generate bubbles.
7. For long-term storage over 40°C is required, the relative humidity should be kept below 60%, and avoid direct sunlight.

Limited Warranty

XIAMEM OCULAR LCDs and modules are not consumer products, but may be incorporated by XIAMEM OCULAR's customers into consumer products or components thereof, XIAMEM OCULAR does not warrant that its LCDs and components are fit for any such particular purpose.

1. The liability of XIAMEM OCULAR is limited to repair or replacement on the terms set forth below. XIAMEM OCULAR will not be responsible for any subsequent or consequential events or injury or damage to any personnel or user including third party personnel and/or user. Unless otherwise agreed in writing between XIAMEM OCULAR and the customer, XIAMEM OCULAR will only replace or repair any of its LCD which is found defective electrically or visually when inspected in accordance with XIAMEM OCULAR general LCD inspection standard . (Copies available on request)
2. No warranty can be granted if any of the precautions state in handling liquid crystal display above has been disregarded. Broken glass, scratches on polarizer mechanical damages as well as defects that are caused accelerated environment tests are excluded from warranty.
3. In returning the LCD/LCM, they must be properly packaged; there should be detailed description of the failures or defect.



US Micro Products

Electronic Products for the OEM

Los Angeles • Austin • New York • Orlando • Shenzhen

(800) 741-7755

www.usmicroproducts.com

Displays

US Micro Products is an industrial distributor specializing in engineered display solutions. We dedicate ourselves to providing the best in displays for the medical, industrial, gaming, automotive, aerospace, military, and consumer markets.

OLEDs



TFT Displays



Open Frame Monitors



Passive LCDs



Multitouch



As a customer, you benefit from our expert knowledge, support and service which allow quick selection and design-in of the best display for your application. On hand stock and demo boards facilitate quick access and evaluation to get you going fast. Our technical sales staff and experienced design engineers provide answers to your questions as well as engineered solutions to solve your display needs.

Peripheral Devices

Our full line of peripheral devices includes keyboards, trackballs, and printers. These rugged industrial products are designed to meet your demanding requirements and are available as both standard and custom solutions.

Keyboards



Trackballs



Aerospace Trackballs



Joysticks



Printers

