



**US Micro Products**  
*Electronic Products for the OEM*

# LCD PRODUCT SPECIFICATION

<b>PART NUMBER:</b>	<b>USMPG-TQ16032C-TBYBH</b>
<b>DESCRIPTION:</b>	160x32 Graphic LCD; STN Blue Display Mode; Transflective, Positive with Yellow-Green LED Backlight and 6 O'Clock Viewing Direction.

ISSUE DATE	APPROVED BY (Customer Use Only)	CHECKED BY	PREPARED BY
<b>PROPRIETARY NOTE:</b>	THIS SPECIFICATION IS THE PROPERTY OF US MICRO PRODUCTS AND SHALL NOT BE REPRODUCED OR COPIED WITHOUT THE WRITTEN PERMISSION OF US MICRO PRODUCTS AND MUST BE RETURNED TO US MICRO PRODUCTS UPON ITS REQUEST.		

### 1、 Features

- 1、 160x32 dots with 8192 chinese character fonts (16x16)
- 2、 Display Mode: STN(Yellow-green), Transflective
- 3、 Viewing angle: 6:00 O'clock
- 4、 Built-in controller (ST7920)
- 5、 128 alpha-numerical fonts (16x8)
- 6、 64x256 bit graphic display RAM
- 7、 Strong display control functions:
- 8、 Vertical scroll, horizontal bit scroll, line reverse etc
- 9、 4 bit, 8 bit, parallel interface
- 10、 LED backlight (Yellow-green) to be driven by PIN15,PIN16

### 2、 Outline dimension

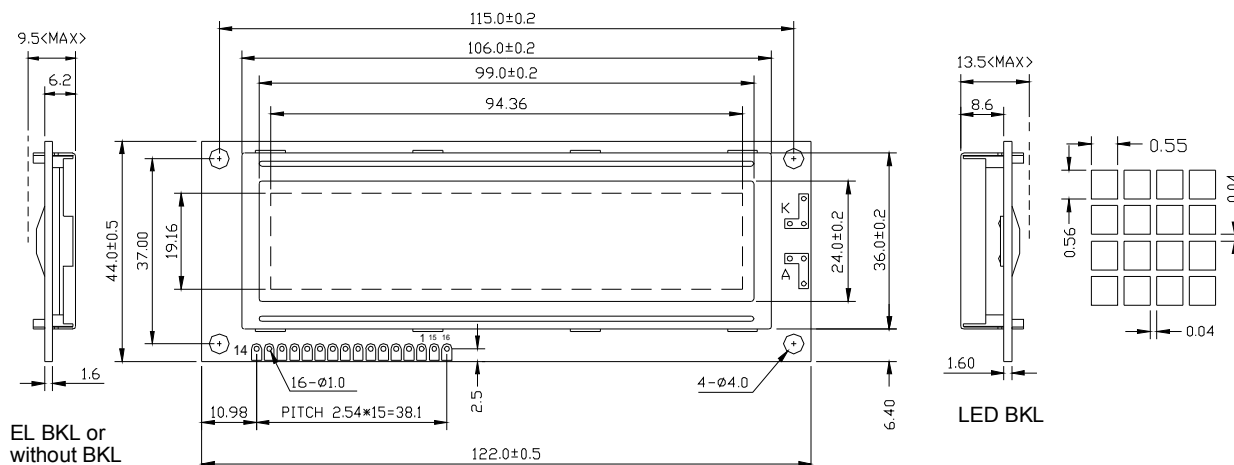

### 3、 Absolute maximum ratings

Item	Symbol	Standard	Standard	Standard	Unit
Power voltage	V <sub>DD</sub> -V <sub>SS</sub>	0	-	7.0	V
Input voltage	V <sub>in</sub>	V <sub>SS</sub>	-	V <sub>DD</sub>	
Operating temperature range	T <sub>op</sub>	-20	-	+70	°C
Storage temperature range	T <sub>st</sub>	-30	-	+80	

CONFIDENTIAL

#### 4、Block diagram

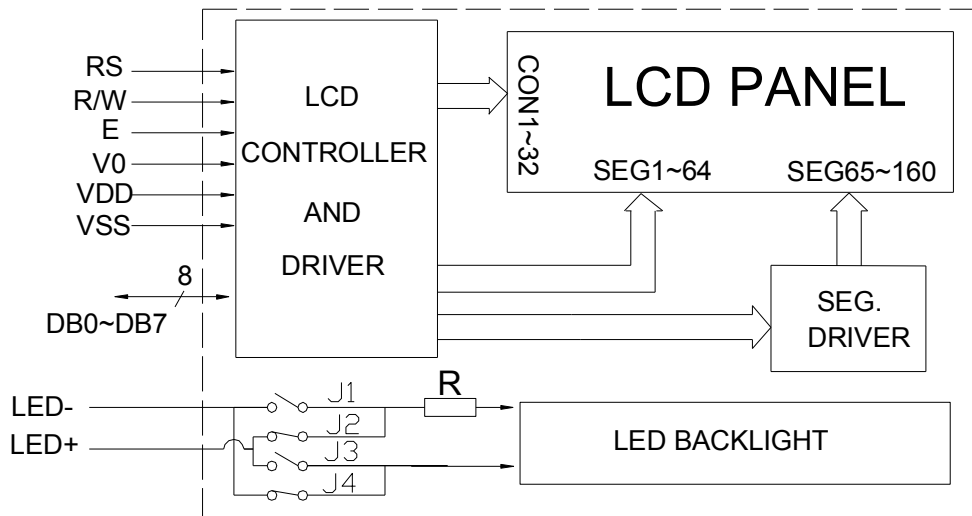

#### 5、Interface pin description

Pin no.	Symbol	External connection	Function
1	V <sub>SS</sub>	Power supply	Signal ground for LCM (GND)
2	V <sub>DD</sub>		Power supply for logic (+5V) for LCM
3	V <sub>0</sub>		Contrast adjust
4	RS	MPU	Register select signal
5	R/W	MPU	Read/write select signal
6	E	MPU	Operation (data read/write) enable signal
7~10	DB0~DB3	MPU	Four low order bi-directional three-state data bus lines. Used for data transfer between the MPU and the LCM. These four are not used during 4-bit operation.
11~14	DB4~DB7	MPU	Four high order bi-directional three-state data bus lines. Used for data transfer between the MPU
15	LED+	LED BKL power supply	Power supply for BKL
16	LED-		Power supply for BKL (GND)

#### 6. Contrast adjust

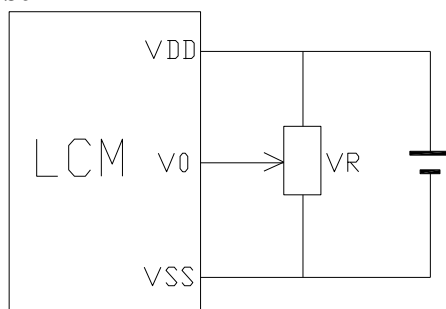

V<sub>DD</sub>-V<sub>0</sub>: LCD Driving voltage

VR: 10k~20k

## 7. Optical characteristics

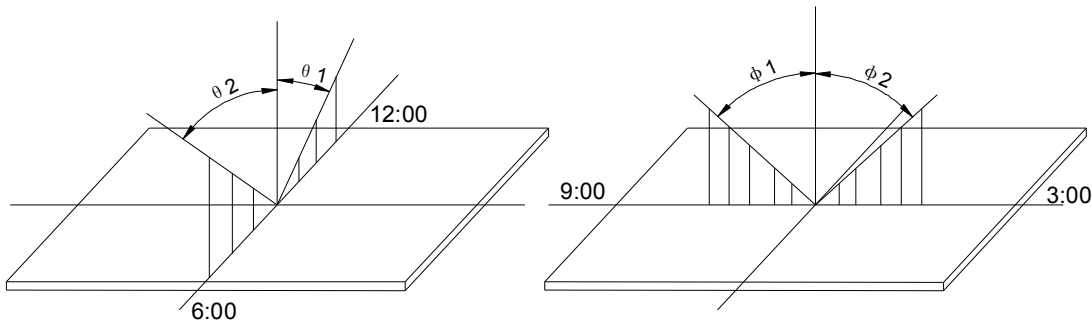

STN type display module (Ta=25°C, VDD=5.0V)

Item	Symbol	Condition	Min.	Typ.	Max.	Unit
Viewing angle	$\theta 1$	$C_r \geq 3$		20		deg
	$\theta 2$			40		
	$\Phi 1$			35		
	$\Phi 2$			35		
Contrast ratio	$C_r$		-	10	-	-
Response time (rise)	$T_r$	-	-	200	250	ms
Response time (fall)	$T_r$	-	-	300	350	

## 8. Electrical characteristics

LED Backlight circuit (color: Yellow-Green)

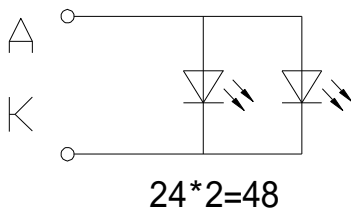

### LED ratings

Item	Symbol	Min	Typ.	Max	Unit
Forward Voltage	Vf	4.0	4.2	4.4	V
Forward current	If	-	240	-	mA
Power	P	-	1	-	W
Peak wave length	$\lambda_p$	568	571	574	nm
Luminance	Lv	-	200	-	Cd/m <sup>2</sup>
Operating temperature range	Vop	-20	-	+70	°C
Storage temperature range	Vst	-30	-	+80	

**DC characteristics**

Parameter	Symbol	Conditions	Min.	Typ.	Max.	Unit
Supply voltage for LCD	$V_{DD}-V_0$	$T_a=25^{\circ}C$ $V=+5V$	-	6.5	-	V
Input voltage	$V_{DD}$	$V=+5V$	4.5	5.0	5.5	
Supply current	$I_{DD}$	$T_a=25^{\circ}C$ , $V_{DD}=5.0V$	-	3.5	4.5	mA
Input leakage current	$I_{LKG}$		-	-	1.0	uA
“H” level input voltage	$V_{IH}$		2.2	-	$V_{DD}$	V
“L” level input voltage	$V_{IL}$	Twice initial value or less	0	-	0.6	
“H” level output voltage	$V_{OH}$	$LOH=-0.25mA$	2.4	-	-	
“L” level output voltage	$V_{OL}$	$LOH=1.6mA$	-	-	0.4	
Backlight supply voltage	$V_F$	$R=6.8\Omega$	-	5.0	-	

**Read cycle ( $T_a=25^{\circ}C$ ,  $V_{DD}=5.0V$ )**

Parameter	Symbol	Test pin	Min.	Typ.	Max.	Unit
Enable cycle time	$t_c$	E	500	-	-	ns
Enable pulse width	$t_w$		300	-	-	
Enable rise/fall time	$t_r, t_f$		-	-	25	
RS; R/W setup time	$t_{su}$	RS; R/W	100	-	-	
RS; R/W address hold time	$t_h$	RS; R/W	10	-	-	
Read data output delay	$t_d$	DB0~DB7	60	-	90	
Read data hold time	$t_{dh}$		20	-	-	

**Write cycle ( $T_a=25^{\circ}C$ ,  $V_{DD}=5.0V$ )**

Parameter	Symbol	Test pin	Min.	Typ.	Max.	Unit
Enable cycle time	$t_c$	E	500	-	-	ns
Enable pulse width	$t_w$		300	-	-	
Enable rise/fall time	$t_r, t_f$		-	-	25	
RS; R/W setup time	$t_{su1}$	RS; R/W	100	-	-	
RS; R/W address hold time	$t_{h1}$	RS; R/W	10	-	-	
Read data output delay	$t_{su2}$	DB0~DB7	60	-	-	
Read data hold time	$t_{h2}$		10	-	-	

**AC Characteristics( $V_{DD}=5V, T_a=25^{\circ}C$ )**

SYMBOL	CHARACTERISTICS	TEST CONDITION	MIN.	TYP.	MAX.	UNIT
FOSC	OSC FREQUENCY	$R_F=39K$	480	540	600	KHZ

**Write mode (writing data from mpu to st7920)**

parameter	symbol	mesure time	unit
SYSTEM CYCLE TIME	TC	13,000	NS
ADDRESS SETUP TIME	tas	1,500	NS
ADDRESS HOLD TIME	TAH	1,500	NS
DATA SETUP TIME	TDSW	1,000	NS
DATA HOLD TIME	TH	20	NS
ENABLE PULSEWIDTH	TPW	1,500	NS
ENABLE RISE/FALL TIME	TR,TF	25	NS

Write Timing

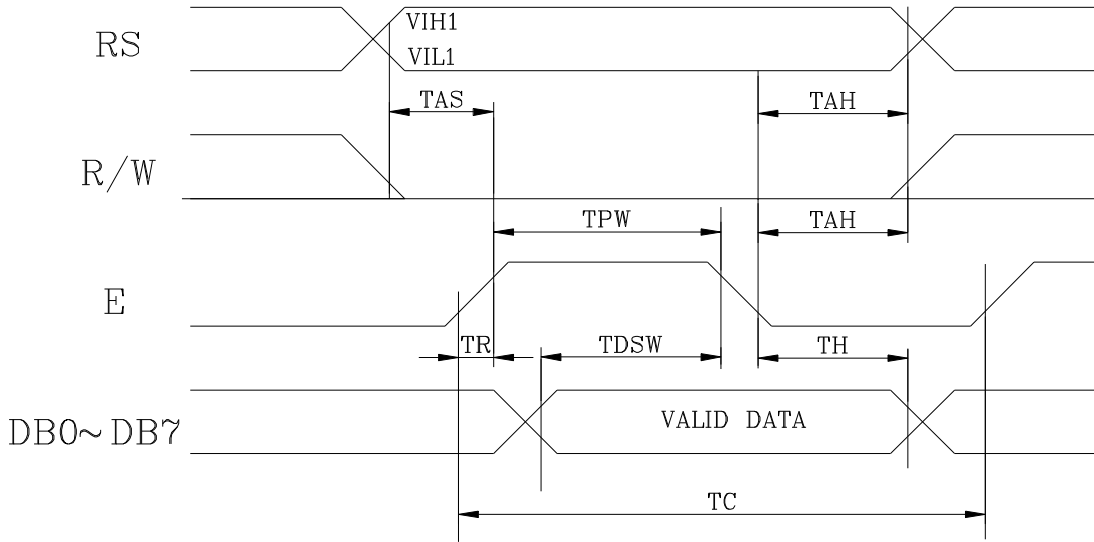

Read mode(READING DATA FORM ST7920 TO MPU)

parameter	symbol	mesure time	unit
SYSTEM CYCLE TIME	TC	13,000	NS
ADDRESS SETUP TIME	tas	1,500	NS
ADDRESS HOLD TIME	TAH	1,500	NS
DATA SETUP TIME	TDDR	1,000	NS
DATA HOLD TIME	TH	20	NS
ENABLE PULSEWIDTH	TPW	1,500	NS
ENABLE RISE/FALL TIME	TR,TF	25	NS

Read timing

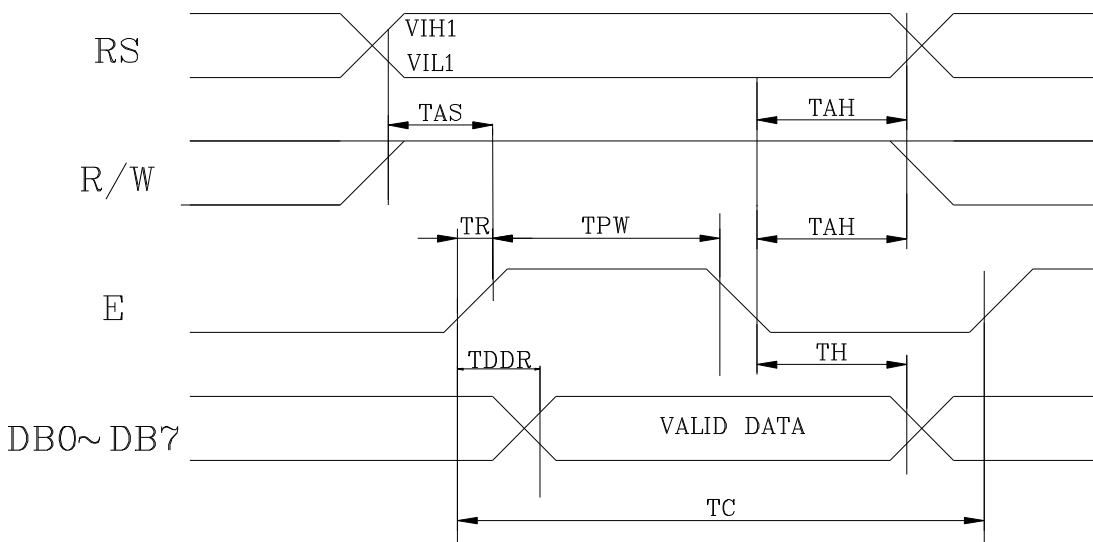

CONFIDENTIAL

## 9. FUNCTION DESCRIPTION

### Character Generator ROM (CGROM)

THE CHARACTER GENERATOR ROM GENERATES 16 X 16 DOT OR 16 X 8 DOT CHARACTER PATTERNS FROM TWO 8-BIT CHARACTER CODES. USER-DEFINED CHARACTER PATTERNS ARE ALSO AVAILABLE BY MASK-PROGRAMMED ROM.

### Character Generator RAM (CGRAM)

IN THE CHARACTER GENERATOR RAM, THE USER CAN REWRITE CHARACTER PATTERNS BY PROGRAM. FOR 16 X 16 DOTS, FOUR CHARACTER PATTERNS CAN BE WRITTEN.

SEE TABLE 1 FOR THE RELATIONSHIP BETWEEN CGRAM ADDRESSES AND DATA AND DISPLAY PATTERNS. AREAS THEY ARE NOT USED FOR DISPLAY CAN BE USED AS GENERAL DATA RAM.

### Timing Generation Circuit

THE TIMING GENERATION CIRCUIT GENERATES TIMING SIGNALS FOR THE OPERATION OF INTERNAL CIRCUITS SUCH AS DDRAM, CGROM AND CGRAM. RAM READ TIMING FOR DISPLAY AND INTERNAL OPERATION TIMING BY MPUACCESS ARE GENERATED SEPARATELY TO AVOID INTERFERING WITH EACH OTHER. THEREFORE, WHEN WRITING DATA TODDRAM, FOR EXAMPLE, THERE WILL BE NO UNDESIRABLE INTERFERENCE, SUCH AS FLICKERING, IN AREAS OTHER THAN THE DISPLAY AREA.

### LCD Driver Circuit

LCD DRIVER CIRCUIT HAS 33 COMMON AND 64 SEGMENT SIGNALS FOR LCD DRIVING. DATA FROM CGRAM/CGROM IS TRANSFERRED TO 64 BIT SEGMENT LATCH SERIALY, AND THEN IT IS STORED TO 64 BIT SHIFT LATCH. WHEN EACH COMMON IS SELECTED BY 33 BIT COMMON REGISTER, SEGMENT DATA ALSO OUTPUT THROUGH SEGMENT DRIVER FROM 64 BIT SEGMENT LATCH.

### Cursor/Blink Control Circuit

IT CAN GENERATE THE CURSOR OR BLINK IN THE CURSOR/BLINK CONTROL CIRCUIT. THE CURSOR OR THE BLINK APPEARS IN THE DIGIT AT THE DISPLAY DATA RAM ADDRESS SET IN THE ADDRESS COUNTER.

CHARACTER CODE DDRAM DATA					CGRAM ADDRESS						CGRAM DATA HIGH BYTE								CGRAM DATA LOW BYTE														
B15~B4	B3	B2	B1	B0	B5	B4	B3	B2	B1	B0	D15	D14	D13	D12	D11	D10	D9	D8	D7	D6	D5	D4	D3	D2	D1	D0							
0	X	0	0	X	0	0	0	0	0	0	0	0	0	0	0	0	0	1	0	0	0	0	0	0	0	0							
							0	0	0	1	0	0	0	0	0	0	0	0	1	1	0	0	0	0	0	0	0	0	0	0	0		
							0	0	1	0	0	0	0	0	1	1	1	1	1	1	1	1	1	1	1	1	1	1	0	0	0	0	
							0	0	1	1	0	0	0	0	0	0	0	0	0	0	1	1	1	1	1	1	0	0	0	0	0	0	
							0	1	0	0	0	0	0	0	0	0	0	1	1	1	1	1	1	1	1	1	0	0	0	0	0	0	
							0	1	0	1	0	0	0	0	0	0	0	1	0	0	0	0	0	0	0	0	1	0	0	0	0	0	
							0	1	1	1	1	0	0	0	0	0	0	0	0	0	0	0	0	0	0	0	0	0	0	0	1	0	0
							0	1	1	1	1	0	0	0	0	0	0	0	0	0	0	0	0	0	0	0	0	0	0	0	0	0	0
							0	1	1	1	1	0	0	0	0	0	0	0	0	0	0	0	0	0	0	0	0	0	0	0	0	0	0
							0	1	1	1	1	0	0	0	0	0	0	0	0	0	0	0	0	0	0	0	0	0	0	0	0	0	0
							0	1	1	1	1	0	0	0	0	0	0	0	0	0	0	0	0	0	0	0	0	0	0	0	0	0	0
							0	1	1	1	1	0	0	0	0	0	0	0	0	0	0	0	0	0	0	0	0	0	0	0	0	0	0
							0	1	1	1	1	0	0	0	0	0	0	0	0	0	0	0	0	0	0	0	0	0	0	0	0	0	0
							0	1	1	1	1	0	0	0	0	0	0	0	0	0	0	0	0	0	0	0	0	0	0	0	0	0	0
							0	1	1	1	1	0	0	0	0	0	0	0	0	0	0	0	0	0	0	0	0	0	0	0	0	0	0
							0	X	0	1	X	0	1	0	0	0	0	0	0	0	0	0	0	1	0	0	0	0	0	0	0	0	0
0	0	0	1	0	0	0								0	0	0	0	0	1	1	0	0	0	0	0	0	0	0	0	0			
0	0	1	0	0	0	0								0	1	1	1	1	1	1	1	1	1	1	1	1	1	1	0	0	0		
0	0	1	1	0	0	0								0	0	0	0	0	0	0	0	0	0	0	0	0	0	0	0	0	0	0	
0	1	0	0	0	0	0								0	0	0	0	1	1	1	1	1	1	1	1	1	0	0	0	0	0	0	
0	1	0	1	0	0	0								0	0	0	0	1	0	0	0	0	0	0	0	1	0	0	0	0	0	0	
0	1	1	1	0	0	0								0	0	0	0	0	0	0	0	0	0	0	0	0	0	0	0	0	0	0	
0	1	1	1	1	0	0								0	0	0	0	0	0	0	0	0	0	0	0	0	0	0	0	0	0	0	
0	1	1	1	1	0	0								0	0	0	0	0	0	0	0	0	0	0	0	0	0	0	0	0	0	0	0
0	1	1	1	1	0	0								0	0	0	0	0	0	0	0	0	0	0	0	0	0	0	0	0	0	0	0
0	1	1	1	1	0	0								0	0	0	0	0	0	0	0	0	0	0	0	0	0	0	0	0	0	0	0
0	1	1	1	1	0	0								0	0	0	0	0	0	0	0	0	0	0	0	0	0	0	0	0	0	0	0
0	1	1	1	1	0	0								0	0	0	0	0	0	0	0	0	0	0	0	0	0	0	0	0	0	0	0
0	1	1	1	1	0	0								0	0	0	0	0	0	0	0	0	0	0	0	0	0	0	0	0	0	0	0
0	1	1	1	1	0	0								0	0	0	0	0	0	0	0	0	0	0	0	0	0	0	0	0	0	0	0

CONFIDENTIAL

**Table1** Relationship Between Cgram Addresses, Character Codes(Ddram) And Character Patterns (Cgram Data)

**Notes:**

1. Character Code Bits 1 To 2 Correspond To Cgram Address Bits 4 To 5 (2 Bit: 4 Types).
2. Cgram Address Bits 0 To 3 Designate The Character Pattern Line Position. The 16th Line Is The Cursor Position And A Logical Or With The Cursor Forms Its Display. Maintain The 16th Line Data,Correspo-Nding To The Cursor Display Position, As To As The Cursor Display. If The 16th Line Data Is 1,1 Bits Will Light Up The 16th Line Regardless Of The Cursor Presence.
- 3.Character Pattern Row Positions Correspond To Cgram Data Bits 0 To 15(Bit 15 Being At The Left).
- \*4.As Shown Table, Cgram Character Patterns Are Selected When Character Code Bits 4 To 15 Are All 0 and Bit 0 And bit 3 are Don'T Care(X).



**TABLE 2** Relationship Between Icon Ram Addresses, Data And Segment Pin Location Bit Map.

		ICON RAM DATA															
		HIGH BYTE								LOW BYTE							
		D15	D14	D13	D12	D11	D10	D9	D8	D7	D6	D5	D4	D3	D2	D1	D0
icon ram address(ac3—ac0)	0	SEG0	SEG1	SEG2	SEG3	SEG4	SEG5	SEG6	SEG7	SEG8	SEG9	SEG10	SEG11	SEG12	SEG13	SEG14	SEG15
	1	SEG16	SEG17	SEG18	SEG19	SEG20	SEG21	SEG22	SEG23	SEG24	SEG25	SEG26	SEG27	SEG28	SEG29	SEG30	SEG31
	2	SEG32	SEG33	SEG34	SEG35	SEG36	SEG37	SEG38	SEG39	SEG40	SEG41	SEG42	SEG43	SEG44	SEG45	SEG46	SEG47
	3	SEG48	SEG49	SEG50	SEG51	SEG52	SEG53	SEG54	SEG55	SEG56	SEG57	SEG58	SEG59	SEG60	SEG61	SEG62	SEG63
	4	SEG64	SEG65	SEG66	SEG67	SEG68	SEG69	SEG70	SEG71	SEG72	SEG73	SEG74	SEG75	SEG76	SEG77	SEG78	SEG79
	5	SEG80	SEG81	SEG82	SEG83	SEG84	SEG85	SEG86	SEG87	SEG88	SEG89	SEG90	SEG91	SEG92	SEG93	SEG94	SEG95
	6	SEG96	SEG97	SEG98	SEG99	SEG100	SEG101	SEG102	SEG103	SEG104	SEG105	SEG106	SEG107	SEG108	SEG109	SEG110	SEG111
	7	SEG112	SEG113	SEG114	SEG115	SEG116	SEG117	SEG118	SEG119	SEG120	SEG121	SEG122	SEG123	SEG124	SEG125	SEG126	SEG127
	8	SEG128	SEG129	SEG130	SEG131	SEG132	SEG133	SEG134	SEG135	SEG136	SEG137	SEG138	SEG139	SEG140	SEG141	SEG142	SEG143
	9	SEG144	SEG145	SEG146	SEG147	SEG148	SEG149	SEG150	SEG151	SEG152	SEG153	SEG154	SEG155	SEG156	SEG157	SEG158	SEG159
	A	SEG160	SEG161	SEG162	SEG163	SEG164	SEG165	SEG166	SEG167	SEG168	SEG169	SEG170	SEG171	SEG172	SEG173	SEG174	SEG175
	B	SEG176	SEG177	SEG178	SEG179	SEG180	SEG181	SEG182	SEG183	SEG184	SEG185	SEG186	SEG187	SEG188	SEG189	SEG190	SEG191
	C	SEG192	SEG193	SEG194	SEG195	SEG196	SEG197	SEG198	SEG199	SEG200	SEG201	SEG202	SEG203	SEG204	SEG205	SEG206	SEG207
	D	SEG208	SEG209	SEG210	SEG211	SEG212	SEG213	SEG214	SEG215	SEG216	SEG217	SEG218	SEG219	SEG220	SEG221	SEG222	SEG223
	E	SEG224	SEG225	SEG226	SEG227	SEG228	SEG229	SEG230	SEG231	SEG232	SEG233	SEG234	SEG235	SEG236	SEG237	SEG238	SEG239
	F	SEG240	SEG241	SEG242	SEG243	SEG244	SEG245	SEG246	SEG247	SEG248	SEG249	SEG250	SEG251	SEG252	SEG253	SEG254	SEG255

CONFIDENTIAL

	0	1	2	3	4	5	6	7	8	9	A	B	C	D	E	F
0	X															
1	▶	◀	‡	!!	¶	§	-	‡	†	↓	→	←	L	++	▼	▲
2		!	"	#	\$	%	&	'	(	)	*	+	,	-	.	/
3	0	1	2	3	4	5	6	7	8	9	:	;	<	=	>	?
4	@	A	B	C	D	E	F	G	H	I	J	K	L	M	N	O
5	P	Q	R	S	T	U	V	W	X	Y	Z	[	\	]	^	_
6	'	a	b	c	d	e	f	g	h	i	j	k	l	m	n	o
7	p	q	r	s	t	u	v	w	x	y	z	{		}	~	Δ

## 10. Instruction description

### DISPLAY COMMAND

THE ST7920 WHICH HAVE TWO CATEGORIES OF INSTRUCTIONS THAT:

**Instruction Table: (RE=0:Enable basic instruction.)**

PARAMETER	RS	RW	DB7	DB6	DB5	DB4	DB3	DB2	DB1	DB0	NOTE	EXECUTION TIME (450KHZ)	
CLEAR DISPLAY	0	0	0	0	0	0	0	0	0	1	Write "20h" To Ddram And Set Ddram Address To "00h" From Ac	2.5MS	
RETURN HOME	0	0	0	0	0	0	0	0	1	X	Set Ddram Address To "00h" From Ac And Return Cursor To Its Original Position If Shifted.The Contents Of Ddram Are Not Change	2.5MS	
ENTRY MODE SET	0	0	0	0	0	0	0	1	ID	S	Sets Cursor Move Direction And Specifies Display Shift. These Operations Are Performed During Data Write And Read	60 MS	
DISPLAY ON/OFF	0	0	0	0	0	0	1	D	C	B	D=1:Entire Display On C=1:Cursor On B=1:Cursor Position On	60 MS	
CURSOR OR DISPLAY SHIFT	0	0	0	0	0	1	S/C	RL	X	X	Set Cursor Moving And Display Shift Control Bit, And The Direction Without Changing Ddram Data	60 MS	
FUNCTION SET	0	0	0	0	1	DL	N	0	RE	G	X	DI:Interface Data Is 8/4 Bits N=1 & Re=0: 3 Line Setting N=1 & Re=1: 4 Line Setting G=1: Graphic Display On G=0: Graphic Display Off Others: 2 Line Setting Re=1: Extended Instruction Setting Re=0: Normal Instruction Setting	60 MS
SET CGRAM ADDRESS	0	0	0	1	AC5	AC4	AC3	AC2	AC1	AC0	Set Cgram Address In Address Corner	60 MS	
SET DDRAM ADDRESS	0	0	1	AC6	AC5	AC4	AC3	AC2	AC1	AC0	Set Ddram Address In Address Corner	60 MS	
READ BUSY FLAG AND ADDRESS	0	1	BF	AC6	AC5	AC4	AC3	AC2	AC1	AC0	Whether During Internal Operation Or Not Can Be Known By Reading Bf . The Contents Of Address Counter Can Also Be Read.	0MS	
WRITE DATA	1	0	D7	D6	D5	D4	D3	D2	D1	D0	Write Data Into Internal Ram	60 MS	
READ DATA	1	1	D7	D6	D5	D4	D3	D2	D1	D0	Read Data From Internal Ram	60 MS	

**Instruction Table: (RE=1: Enable extension instruction.)**

PARAMETER	RS	R/W	DB7	DB6	DB5	DB4	DB3	DB2	DB1	DB0	NOTE	EXECUTION TIME (450KHZ)
STANDBY MODE	0	0	0	0	0	0	0	0	0	1	Enter Standby Mode, Only Icon Areas Display. Standby Mode Can Be Released By Any Other Instructions.	60 US
START ROW ENABLE	0	0	0	0	0	0	0	0	1	SR	Sr=1: Allow Change Start Display Row. Sr=0: Disable Start Display Row Change.	60US
REVERSE LINE SELECT	0	0	0	0	0	0	0	1	R1	R0	Choice One Of 4 Lines Which Data Is Reverse Display.	60MS
SLEEP MODE AND SET GRAM PAGE	0	0	0	0	0	0	1	D	C	B	Sl=0: Enter Sleep Mode. Sl=1: Wake-Up From Sleep Mode Gd: Display Graphic Page 0 Or 1 Gw: Write Data To Graphic Page 0 Or 1. (Effective While Gp=1)	60MS
DISPLAY SHIFT BY DOT	0	0	0	0	0	1	OA	LR	L1	L0	Oa=1: One Of 4 Lines Shift Enable. Oa=0: All Line Shift Enable. Lr=1: Dot By Dot Shift Right. Lr=0: Dot By Dot Shift Left.  Ll,L0: Choice One Of 4 Lines Shift	60MS
FUNCTION SET (MODIFY)	0	0	0	0	1	CL	N	1 RE	G	GP	Cl=1: Select 16 Character Line Cl=0: Select 8 Character Line N=1 & Re=1: 4 Line Display Re=1: Extended Instruction Setting. Re=0: Normal Instruction Setting. G=1: Graphic Display On G=0: Graphic Display Off Gp=1: Two Page Gram Gp=0: One Page Gram	60MS
Set IRAM or Start Row ADDRESS	0	0	0	1	AC5	AC4	AC3	AC2	AC1	AC0	Sr=1: Ac5~Ac0 Is Start Row Sr=0: Ac5~Ac0 Is Icon Ram Address	60MS
SET GRAPHIC RAM ADDRESS	0	0	1	AC6	AC5	AC4	AC3	AC2	AC1	AC0	Set Graphic Ram Address In Address Counter. Execute Once Set The Address Of Display Row. Execute Again Set The Address Of Display Column. Each Address Of Display Column Has Data Of 16 Bits. Therefore Write Data Should Execute 2 Times.	60MS

**CONFIDENTIAL**

**NOTE:**

Be sure the st7920 is not in the busy state ( $bf = 0$ ) before sending an instruction from the mpu to

The st7920. if an instruction is sent without checking the busy flag, the time between the first instruction and next instruction will take much longer than the instruction time itself. Refer to instruction table for the list of each instruction execution time.

**1. Serial Interface & Transferring Serial Data**

The st7920 enters serial mode when the psb pin is set low. A two-line clock synchronous transfer method is used. The st7920 receives serial input data(sid) by synchronizing with a transfer clock(sclk) sent from the master side. When the st7920 interfaces with several chips, chip select pin(cs) must be used. The transfer clock(sclk) input is activated by making chip select(cs) high. In addition, the transfer counter of the st7920 can be reset and serial transfer synchronized by making chip select(cs) low. Here, since the data which was being sent at reset is cleared, restart the transfer from the first bit of this data. In a minimum system where a single st7920 interfaces to a single mpu, an interface can be constructed from the transfer clock(sclk) and serial input data(sid). In this case, chip select(cs) should be fixed to high.

the transfer clock(sclk) is independent of operational clock of the st7920. however, when several instructions are continuously transferred, the instruction execution time determined by the operational clock must be considered since the st7920 does not have an internal transmit/receive buffer. Following figure shows the basic procedure for transferring serial data. To begin with, transfer the start byte. By receiving five consecutive bits of 1 (synchronizing bit string) at the beginning of the start byte, the transfer counter of the st7920 is reset and serial transfer is synchronized. The 2 bits following the synchronizing bit string (5 bits) specify transfer direction (rw bit) and register select (rs bit). Be sure to transfer 0 in the 8th bit.

After receiving the start synchronizing bit string, the rw bit (=0), and rs bit in the start byte, an 8-bit instruction is received in 2 bytes: the higher 4 bits of the instruction are placed in the lsb of the first byte, and the lower 4 bits of the instruction are placed in the lsb of the second byte. Be sure to transfer 0 in the following 4 bits of each byte.

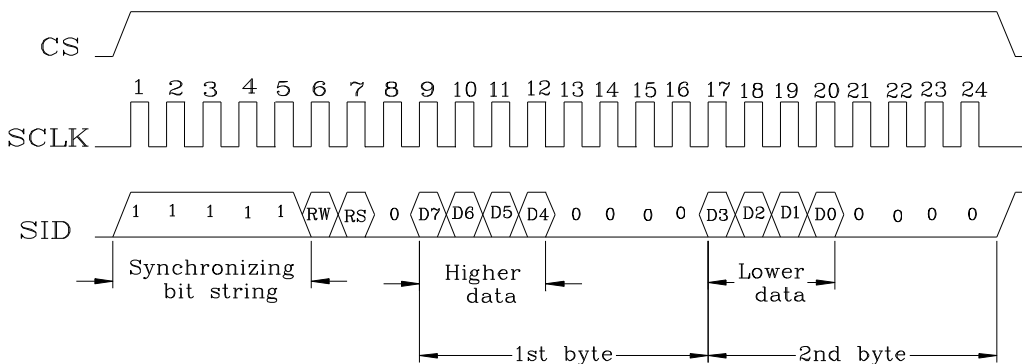

CONFIDENTIAL

## 2. INITIALIZING BY INSTRUCTION

### 1 8-BIT INTERFACE:

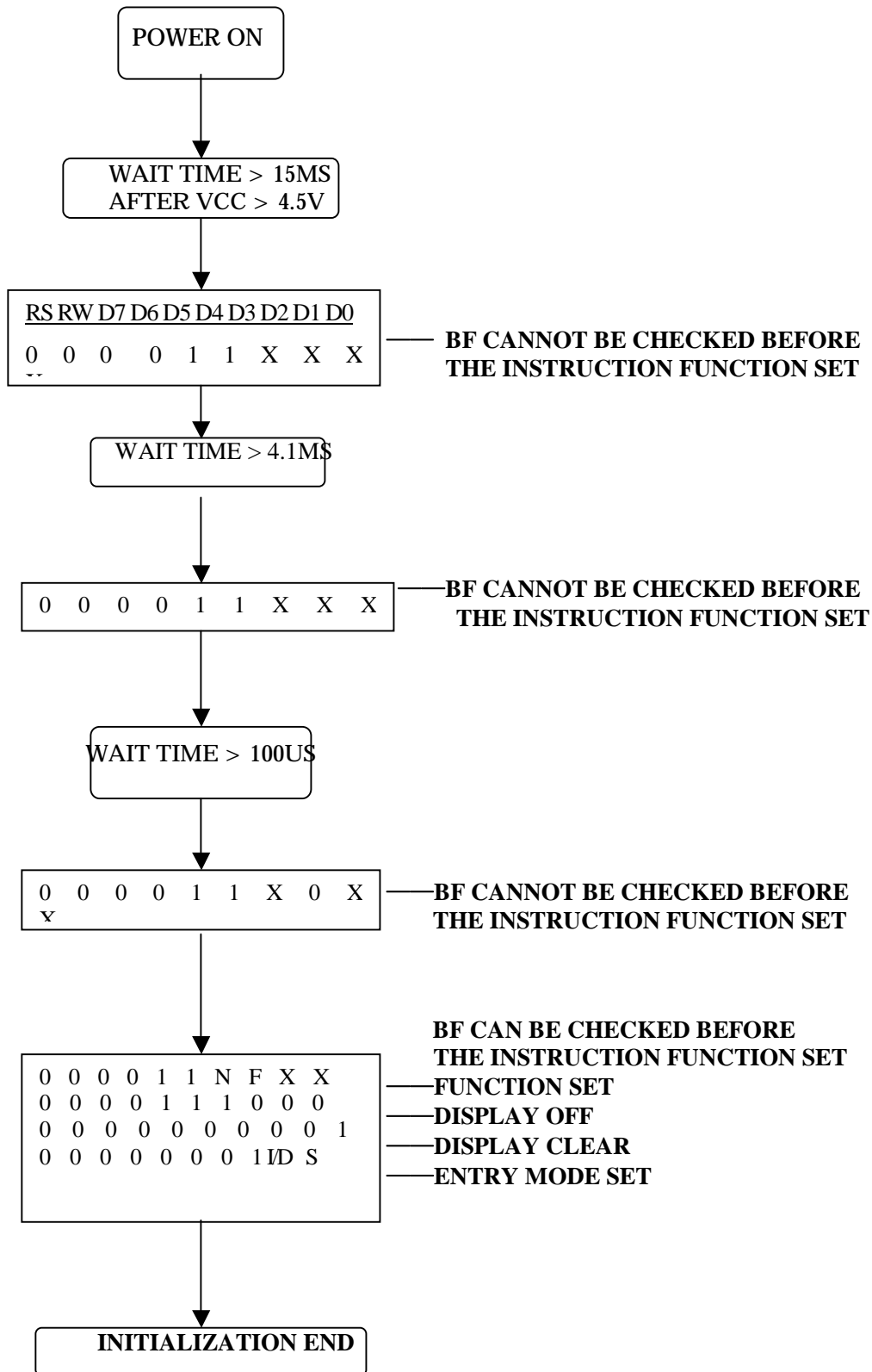

CONFIDENTIAL

**I 4-BIT INTERFACE**

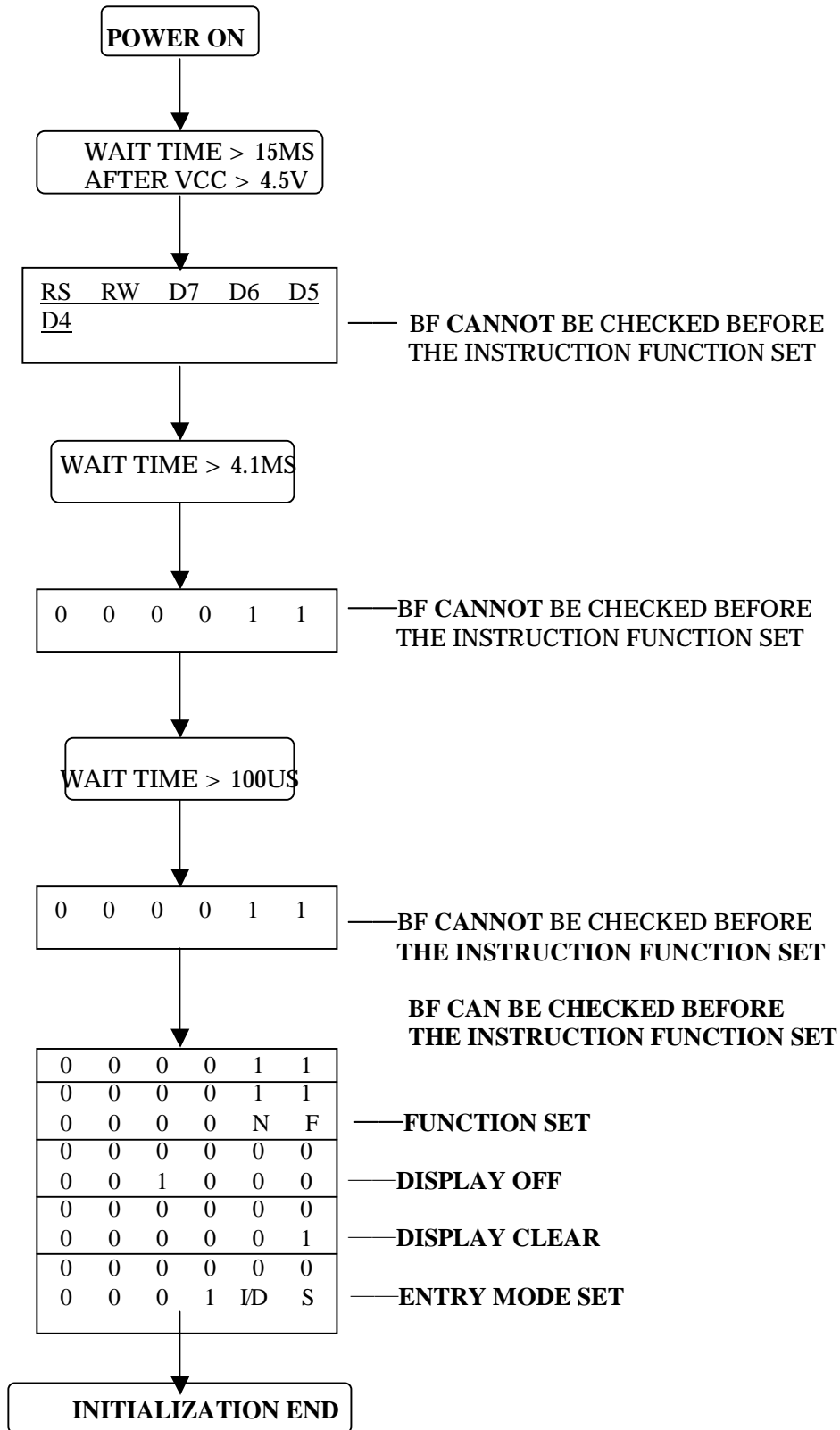

CONFIDENTIAL

## 11.QUALITY SPECIFICATIONS

### 11.1 Standard of the product appearance test

Manner of appearance test: The inspection should be performed in using 20W x 2 fluorescent lamps. Distance between LCM and fluorescent lamps should be 100 cm or more. Distance between LCM and inspector eyes should be 25 cm or more.

Viewing direction for inspection is 35° from vertical against LCM.

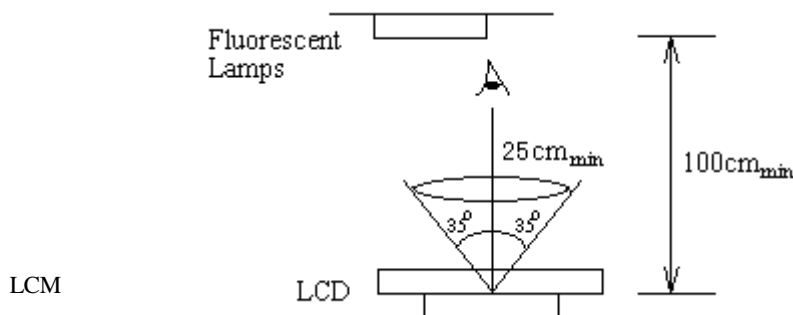

Definition of zone:

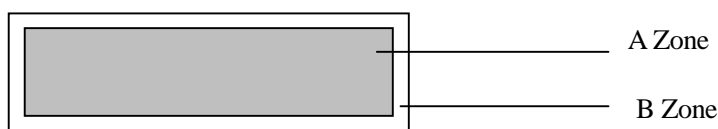

A Zone: Active display area (minimum viewing area).  
B Zone: Non-active display area (outside viewing area).

### 11.2 Specification of quality assurance

AQL inspection standard

Sampling method: GB2828-87, Level II, single sampling

Defect classification **(Note: \* is not including)**

Classify	Item	Note	AQL	
Major	Display state	Short or open circuit	1	0.65
		LC leakage		
		Flickering		
		No display		
		Wrong viewing direction		
		Contrast defect (dim, ghost)		
	Back-light	1,8		
Non-display	Flat cable or pin reverse	10		
	Wrong or missing component	11		
Minor	Display state	Background color deviation	2	1.0
		Black spot and dust	3	
		Line defect, Scratch	4	
		Rainbow	5	
		Chip	6	
		Pin hole	7	
		Polarizer	Protruded	
	Bubble and foreign material		3	
	Soldering	Poor connection	9	
	Wire	Poor connection	10	
	TAB	Position, Bonding strength	13	

**Note on defect classification**

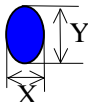
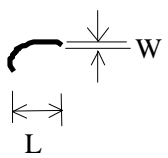
No.	Item	Criterion												
1	Short or open circuit	Not allow												
	LC leakage													
	Flickering													
	No display													
	Wrong viewing direction													
	Wrong Back-light													
2	Contrast defect	Refer to approval sample												
	Backgroundcolor deviation													
3	Point defect, Black spot, dust (including Polarizer)  $\phi = (X+Y)/2$	 <table border="1" data-bbox="861 840 1300 1097"> <thead> <tr> <th>Point Size</th> <th>Acceptable Qty.</th> </tr> </thead> <tbody> <tr> <td><math>\phi \leq 0.10</math></td> <td>Disregard</td> </tr> <tr> <td><math>0.10 &lt; \phi \leq 0.15</math></td> <td>2</td> </tr> <tr> <td><math>0.15 &lt; \phi \leq 0.25</math></td> <td>1</td> </tr> <tr> <td><math>\phi &gt; 0.25</math></td> <td>0</td> </tr> </tbody> </table> <p style="text-align: center;">Unit: Inch<sup>2</sup></p>	Point Size	Acceptable Qty.	$\phi \leq 0.10$	Disregard	$0.10 < \phi \leq 0.15$	2	$0.15 < \phi \leq 0.25$	1	$\phi > 0.25$	0		
Point Size	Acceptable Qty.													
$\phi \leq 0.10$	Disregard													
$0.10 < \phi \leq 0.15$	2													
$0.15 < \phi \leq 0.25$	1													
$\phi > 0.25$	0													
4	Line defect, Scratch	 <table border="1" data-bbox="790 1321 1340 1500"> <thead> <tr> <th colspan="2">Line</th> <th rowspan="2">Acceptable Qty.</th> </tr> <tr> <th>L</th> <th>W</th> </tr> </thead> <tbody> <tr> <td>---</td> <td><math>0.05 &gt; W</math></td> <td rowspan="3">Disregard</td> </tr> <tr> <td><math>3.0 &gt; L</math></td> <td><math>0.1 &gt; W &gt; 0.05</math></td> </tr> <tr> <td><math>2.0 &gt; L</math></td> <td><math>0.15 \geq W &gt; 0.1</math></td> </tr> </tbody> </table> <p style="text-align: center;">Unit: mm</p>	Line		Acceptable Qty.	L	W	---	$0.05 > W$	Disregard	$3.0 > L$	$0.1 > W > 0.05$	$2.0 > L$	$0.15 \geq W > 0.1$
Line		Acceptable Qty.												
L	W													
---	$0.05 > W$	Disregard												
$3.0 > L$	$0.1 > W > 0.05$													
$2.0 > L$	$0.15 \geq W > 0.1$													
5	Rainbow	Not more than two color changes across the viewing area.												

CONFIDENTIAL

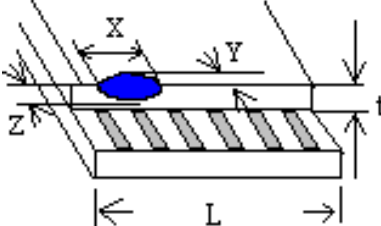
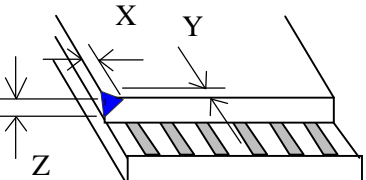
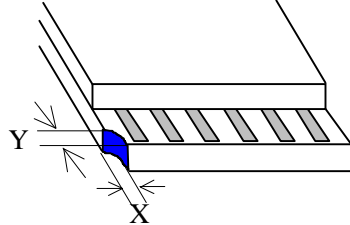
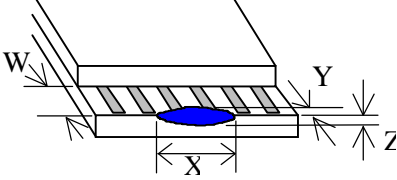
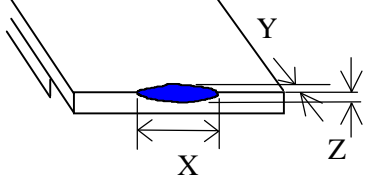

CONFIDENTIAL

No	Item	Criterion																																	
6	<p>Chip</p> <p>Remark:                      X: Length direction                      Y: Short direction                      Z: Thickness direction                      t: Glass thickness                      W: Terminal Width                      L: Glass length</p>	 <p>Acceptable criterion</p> <table border="1" data-bbox="933 324 1316 392"> <thead> <tr> <th>X</th> <th>Y</th> <th>Z</th> </tr> </thead> <tbody> <tr> <td><math>&lt; L/8</math></td> <td>0.5mm</td> <td><math>\leq t/2</math></td> </tr> </tbody> </table>  <p>Acceptable criterion</p> <table border="1" data-bbox="917 638 1316 705"> <thead> <tr> <th>X</th> <th>Y</th> <th>Z</th> </tr> </thead> <tbody> <tr> <td><math>\leq 2</math></td> <td>0.5mm</td> <td><math>\leq t</math></td> </tr> </tbody> </table>  <p>Acceptable criterion</p> <table border="1" data-bbox="933 929 1316 1041"> <thead> <tr> <th>X</th> <th>Y</th> <th>Z</th> </tr> </thead> <tbody> <tr> <td><math>\leq 3</math></td> <td><math>\leq 2</math></td> <td><math>\leq t</math></td> </tr> <tr> <td colspan="2">shall not reach to ITO</td> <td></td> </tr> </tbody> </table>  <p>Acceptable criterion</p> <table border="1" data-bbox="917 1310 1316 1377"> <thead> <tr> <th>X</th> <th>Y</th> <th>Z</th> </tr> </thead> <tbody> <tr> <td>Disregard</td> <td><math>\leq 0.2</math></td> <td><math>\leq t</math></td> </tr> </tbody> </table>  <p>Acceptable criterion</p> <table border="1" data-bbox="917 1590 1292 1657"> <thead> <tr> <th>X</th> <th>Y</th> <th>Z</th> </tr> </thead> <tbody> <tr> <td><math>\leq 5</math></td> <td><math>\leq 2</math></td> <td><math>\leq t/3</math></td> </tr> </tbody> </table>	X	Y	Z	$< L/8$	0.5mm	$\leq t/2$	X	Y	Z	$\leq 2$	0.5mm	$\leq t$	X	Y	Z	$\leq 3$	$\leq 2$	$\leq t$	shall not reach to ITO			X	Y	Z	Disregard	$\leq 0.2$	$\leq t$	X	Y	Z	$\leq 5$	$\leq 2$	$\leq t/3$
X	Y	Z																																	
$< L/8$	0.5mm	$\leq t/2$																																	
X	Y	Z																																	
$\leq 2$	0.5mm	$\leq t$																																	
X	Y	Z																																	
$\leq 3$	$\leq 2$	$\leq t$																																	
shall not reach to ITO																																			
X	Y	Z																																	
Disregard	$\leq 0.2$	$\leq t$																																	
X	Y	Z																																	
$\leq 5$	$\leq 2$	$\leq t/3$																																	

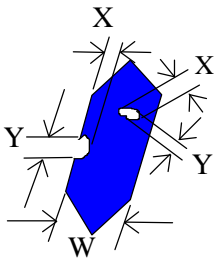
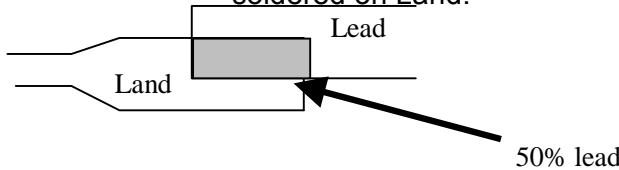
No.	Item	Criterion								
7	Segment pattern W = Segment width $\phi = (X+Y)/2$	<p>(1) Pin hole <math>\phi &lt; 0.10\text{mm}</math> is acceptable.</p>  <table border="1" data-bbox="853 425 1316 604"> <thead> <tr> <th>Point Size</th> <th>Acceptable Qty</th> </tr> </thead> <tbody> <tr> <td><math>\phi \leq 1/4W</math></td> <td>Disregard</td> </tr> <tr> <td><math>1/4W &lt; \phi \leq 1/2W</math></td> <td>1</td> </tr> <tr> <td><math>\phi &gt; 1/2W</math></td> <td>0</td> </tr> </tbody> </table> <p style="text-align: right;">Unit: mm</p>	Point Size	Acceptable Qty	$\phi \leq 1/4W$	Disregard	$1/4W < \phi \leq 1/2W$	1	$\phi > 1/2W$	0
Point Size	Acceptable Qty									
$\phi \leq 1/4W$	Disregard									
$1/4W < \phi \leq 1/2W$	1									
$\phi > 1/2W$	0									
8	Back-light	<p>(1) The color of backlight should correspond its specification.</p> <p>(2) Not allow flickering</p>								
9	Soldering	<p>(1) Not allow heavy dirty and solder ball on PCB.</p> <p>(The size of dirty refer to point and dust defect)</p> <p>(2) Over 50% of lead should be soldered on Land.</p> 								
10	Wire	<p>(1) Copper wire should not be rusted</p> <p>(2) Not allow crack on copper wire connection.</p> <p>(3) Not allow reversing the position of the flat cable.</p> <p>(4) Not allow exposed copper wire inside the flat cable.</p>								
11*	PCB	<p>(1) Not allow screw rust or damage.</p> <p>(2) Not allow missing or wrong putting of component.</p>								

CONFIDENTIAL

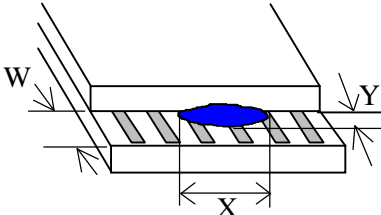
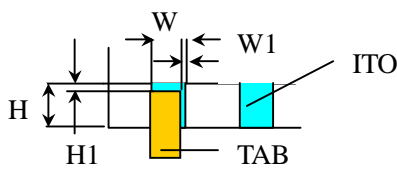
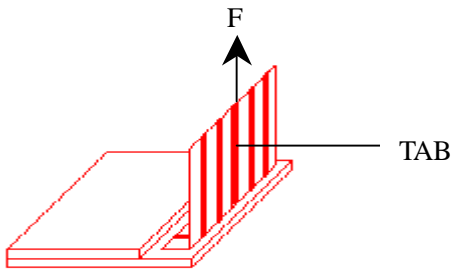
No	Item	Criterion
12	Protruded W: Terminal Width	 <p>Acceptable criteria: <math>Y \leq 0.4</math></p>
13	TAB	<p>1. Position</p>  <div style="border: 1px solid black; padding: 5px; width: fit-content; margin-left: auto;"> <math>W1 \leq 1/3W</math>  <math>H1 \leq 1/3H</math> </div> <p>2. TAB bonding strength test</p>  <p><math>P (=F/TAB \text{ bonding width}) \geq 650\text{gf/cm}</math> ,(speed rate: 1mm/min) 5pcs per SOA (shipment)</p>
14	Total no. of acceptable Defect	<p>A. Zone</p> <p>Maximum 2 minor non-conformities per one unit. Defect distance: each point to be separated over 10mm</p> <p>B. Zone</p> <p>It is acceptable when it is no trouble for quality and assembly in customer's end product.</p>

CONFIDENTIAL

### 11.3 Reliability of LCM

Reliability test condition:

Item	Condition	Time (hrs)	Assessment
High temp. Storage	80°C	48	No abnormalities in functions and appearance
High temp. Operating	70°C	48	
Low temp. Storage	-30°C	48	
Low temp. Operating	-20°C	48	
Humidity	40°C/ 90%RH	48	
Temp. Cycle	0°C ← 25°C → 50°C (30 min ← 5 min → 30min)	10cycles	

Recovery time should be 24 hours minimum. Moreover, functions, performance and appearance shall be free from remarkable deterioration within 50,000 hours under ordinary operating and storage conditions room temperature (20±8°C), normal humidity (below 65% RH), and in the area not exposed to direct sun light.

### 11.4 Precaution for using LCD/LCM

LCD/LCM is assembled and adjusted with a high degree of precision. Do not attempt to make any alteration or modification. The followings should be noted.

#### General Precautions:

1. LCD panel is made of glass. Avoid excessive mechanical shock or applying strong pressure onto the surface of display area.
2. The polarizer used on the display surface is easily scratched and damaged. Extreme care should be taken when handling. To clean dust or dirt off the display surface, wipe gently with cotton, or other soft material soaked with isopropyl alcohol, ethyl alcohol or trichlorotrifluoroethane, do not use water, ketone or aromatics and never scrub hard.
3. Do not tamper in any way with the tabs on the metal frame.
4. Do not make any modification on the PCB without consulting **USMP**
5. When mounting a LCM, make sure that the PCB is not under any stress such as bending or twisting. Elastomer contacts are very delicate and missing pixels could result from slight dislocation of any of the elements.
6. Avoid pressing on the metal bezel, otherwise the elastomer connector could be deformed and lose contact, resulting in missing pixels and also cause rainbow on the display.
7. Be careful not to touch or swallow liquid crystal that might leak from a damaged cell. Any liquid crystal adheres to skin or clothes, wash it off immediately with soap and water.

#### Static Electricity Precautions:

1. CMOS-LSI is used for the module circuit; therefore operators should be grounded whenever he/she comes into contact with the module.
2. Do not touch any of the conductive parts such as the LSI pads; the copper leads on the PCB and the interface terminals with any parts of the human body.
3. Do not touch the connection terminals of the display with bare hand; it will cause disconnection or

- defective insulation of terminals.
4. The modules should be kept in anti-static bags or other containers resistant to static for storage.
  5. Only properly grounded soldering irons should be used.
  6. If an electric screwdriver is used, it should be grounded and shielded to prevent sparks.
  7. The normal static prevention measures should be observed for work clothes and working benches.
  8. Since dry air is inductive to static, a relative humidity of 50-60% is recommended.

**Soldering Precautions:**

1. Soldering should be performed only on the I/O terminals.
2. Use soldering irons with proper grounding and no leakage.
3. Soldering temperature:  $280^{\circ}\text{C}\pm 10^{\circ}\text{C}$
4. Soldering time: 3 to 4 second.
5. Use eutectic solder with resin flux filling.
6. If flux is used, the LCD surface should be protected to avoid spattering flux.
7. Flux residue should be removed.

**Operation Precautions:**

1. The viewing angle can be adjusted by varying the LCD driving voltage  $V_o$ .
2. Since applied DC voltage causes electro-chemical reactions, which deteriorate the display, the applied pulse waveform should be a symmetric waveform such that no DC component remains. Be sure to use the specified operating voltage.
3. Driving voltage should be kept within specified range; excess voltage will shorten display life.
4. Response time increases with decrease in temperature.
5. Display color may be affected at temperatures above its operational range.
6. Keep the temperature within the specified range usage and storage. Excessive temperature and humidity could cause polarization degradation, polarizer peel-off or generate bubbles.
7. For long-term storage over  $40^{\circ}\text{C}$  is required, the relative humidity should be kept below 60%, and avoid direct sunlight.

CONFIDENTIAL



# US Micro Products

*Electronic Products for the OEM*

Los Angeles • Austin • New York • Orlando • Shenzhen

(800) 741-7755

[www.usmicroproducts.com](http://www.usmicroproducts.com)

## Displays

US Micro Products is an industrial distributor specializing in engineered display solutions. We dedicate ourselves to providing the best in displays for the medical, industrial, gaming, automotive, aerospace, military, and consumer markets.

### OLEDs



### TFT Displays



### Open Frame Monitors



### Passive LCDs



### Multitouch



As a customer, you benefit from our expert knowledge, support and service which allow quick selection and design-in of the best display for your application. On hand stock and demo boards facilitate quick access and evaluation to get you going fast. Our technical sales staff and experienced design engineers provide answers to your questions as well as engineered solutions to solve your display needs.

## Peripheral Devices

Our full line of peripheral devices includes keyboards, trackballs, and printers. These rugged industrial products are designed to meet your demanding requirements and are available as both standard and custom solutions.

### Keyboards



### Trackballs



### Aerospace Trackballs



### Joysticks



### Printers

