



US Micro Products
Electronic Products for the OEM

LCD PRODUCT SPECIFICATION

PART NUMBER:	USMPG-TQ12864C-SZWFK
DESCRIPTION:	128x64 Graphic LCD; FSTN Display Mode; Transmissive, Negative with White LED Sidelight and 12 O'Clock Viewing Direction.

ISSUE DATE	APPROVED BY (Customer Use Only)	CHECKED BY	PREPARED BY
PROPRIETARY NOTE:	THIS SPECIFICATION IS THE PROPERTY OF US MICRO PRODUCTS AND SHALL NOT BE REPRODUCED OR COPIED WITHOUT THE WRITTEN PERMISSION OF US MICRO PRODUCTS AND MUST BE RETURNED TO US MICRO PRODUCTS UPON ITS REQUEST.		

LCD MODULE SPECIFICATION

MODULE TYPE: _____

CONFIDENTIAL

Prepared By	Checked By	Approved By	MT File NO.	Date Issued

CONTENTS

	Item	Page
1	Features	3
2	Mechanical Specifications	3
3	Outline Dimension	4
4	Absolute Maximum Ratings	5
5	Block Diagram	5
6	Interface Pin Description	5
7	Contrast adjust	6
8	Optical Characteristics	6
9	Electrical Characteristics	6 ~ 9
10	Display Control Instruction	10 ~ 11
11	Quality Specifications	12 ~18

CONFIDENTIAL

To be very careful!

The LCD drivers ICs are made by COMS process, which are very easy to be damaged by static charge, make sure the user is grounded when handling the LCM.

1.Features

1. Display format: 128*64 dots matrix graphic
2. FSTN DOUBLE FILM mode, transmissive
3. Driving method: 1/64 duty, 1/9 bias
4. Easy interface with 8-bit MPU
5. Low power consumption
6. LED backlight (White)
7. Viewing angle: 12:00 O'clock
8. LCD driver IC: NT7107C、NT7108C
9. Connector: zebra

LCD type	<input type="radio"/> TN positive	<input type="radio"/> TN Negative	
	<input type="radio"/> STN Yellow Green	<input type="radio"/> STN Gray	<input type="radio"/> STN Blue
	<input checked="" type="checkbox"/> FSTN		
View direction	<input type="radio"/> 6 O'clock	<input checked="" type="checkbox"/> 12 O'clock	
Rear Polarizer	<input type="radio"/> Reflective	<input type="radio"/> Transflective	<input checked="" type="checkbox"/> Transmissive
	<input type="radio"/> Transflective (High Transmissive)		
Backlight Type	<input checked="" type="checkbox"/> LED	<input type="radio"/> Internal Power	<input checked="" type="checkbox"/> 5.0V input
	<input type="radio"/> EL	<input checked="" type="checkbox"/> External Power	<input type="radio"/> 3.3 input
	<input type="radio"/> CCFL		<input type="radio"/> 4.2V input
Backlight Color	<input checked="" type="checkbox"/> White	<input type="radio"/> Amber	<input type="radio"/> Blue-Green
	<input type="radio"/> Pure -Green	<input type="radio"/> Yellow-Green	<input type="radio"/> Red
		<input type="radio"/> Blue	
Temperature Range	<input type="radio"/> Normal	<input checked="" type="checkbox"/> Wide	<input type="radio"/> Super Wide
Font type	<input type="checkbox"/> English-Japanese		
	<input type="radio"/> English-European		
	<input type="radio"/> English-Russian		
	<input type="radio"/> Other		
DC to DC circuit	<input type="radio"/> Build-in	<input checked="" type="checkbox"/> Not Build-in	
EI Driver IC	<input type="radio"/> Build-in	<input checked="" type="checkbox"/> Not Build-in	
Touch screen	<input type="radio"/> With	<input checked="" type="checkbox"/> Without	

2.Mechanical Specifications

Item	Dimension	Unit
Viewing Area (W*H)	72 * 40	mm
Display Format	128 * 64 dots	
Dot Size (W*H)	0.48 * 0.48	mm
Dot Pitch (W*H)	0.52 * 0.52	mm
Module Size With B/L	93 * 70 * 13	mm

CONFIDENTIAL

CONFIDENTIAL

3- Outline dimension

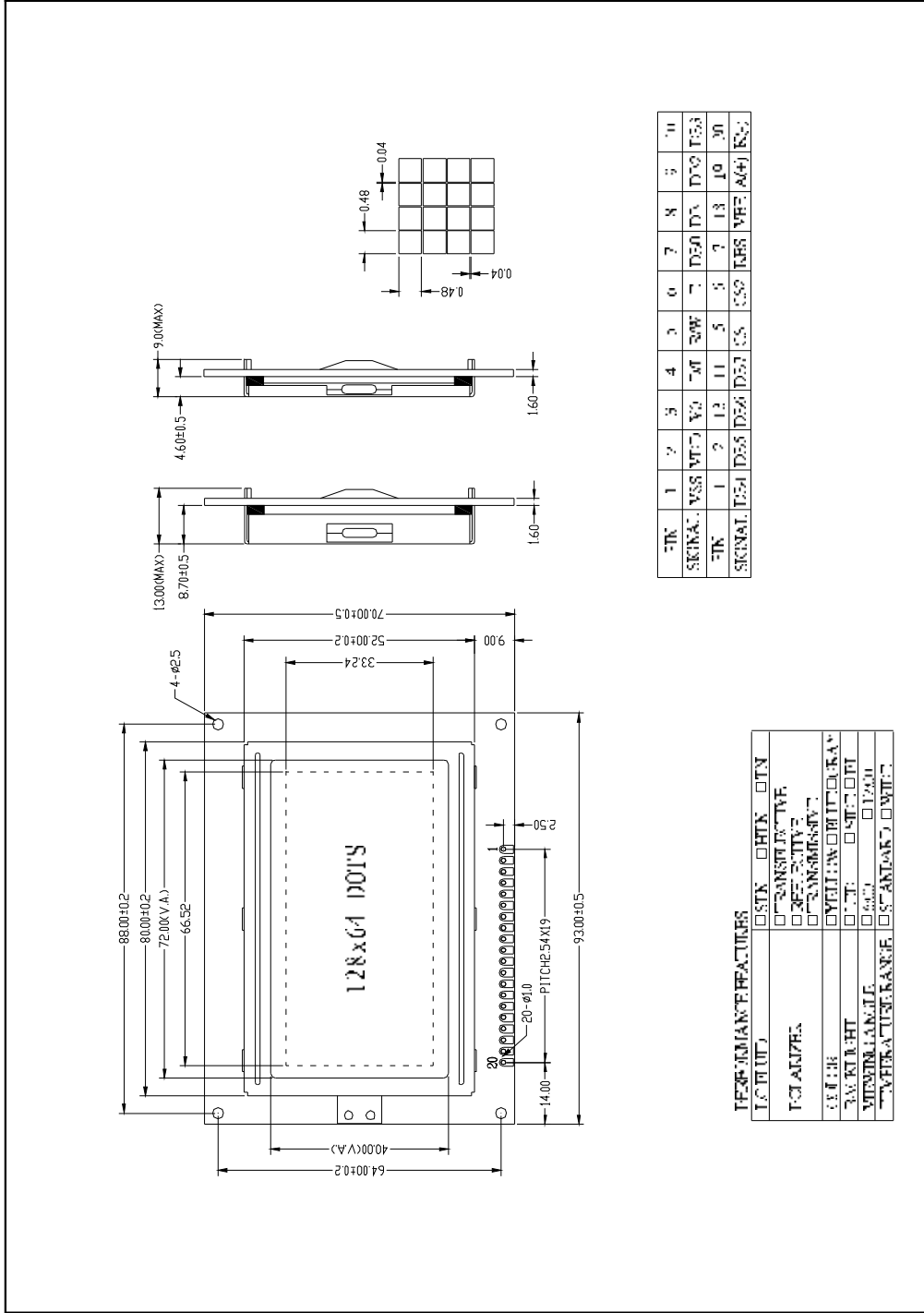

4. Absolute maximum ratings

Item	Symbol	Standard			Unit
Power voltage	$V_{DD}-V_{SS}$	0	-	7.0	V
Input voltage	V_{in}	VSS	-	VDD	
Operating temperature range	T_{op}	-20	-	+70	°C
Storage temperature range	T_{st}	-30	-	+80	

5. Block diagram

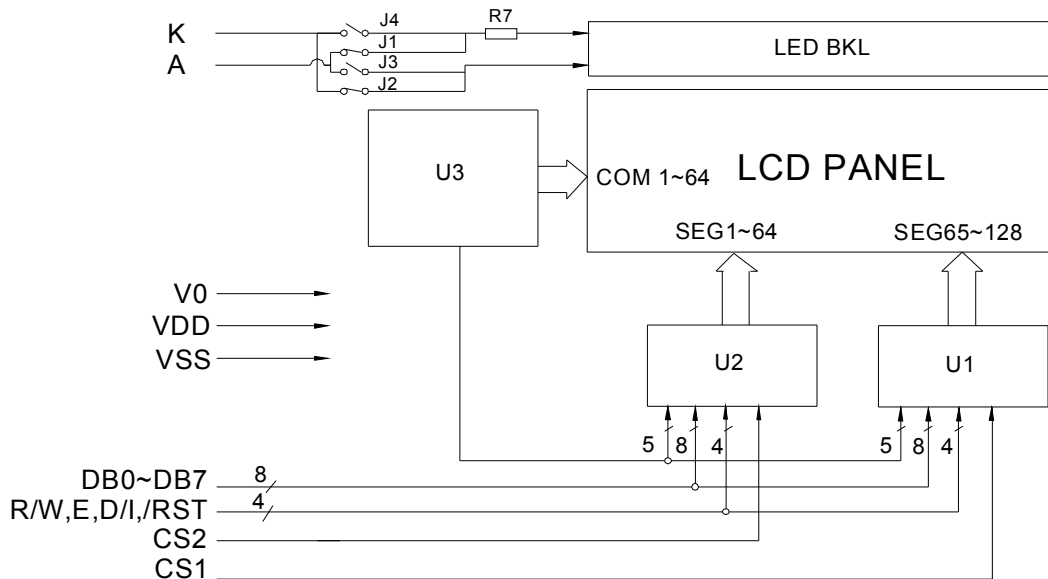

6. Interface pin description

PIN NO.	PIN NAME	INPUT/OUTPUT	EXTERNAL CONNECTION	FUNCTION
1	VSS		POWER SUPPLY	VSS: GND
2	VDD			VDD: +5.0V
3	V0			CONTRAST ADJUST
4	D/I		MPU	Data or Instruction register select signal.
5	R/W		MPU	Read or Write select signal
6	E		MPU	Operation (data read/write) enable signal
7~14	DB0~DB7		MPU	Data bus. Three state I/O common terminal.
15	CS1	---	MPU	Chip selection
16	CS2		MPU	When CS1=L, CS2=H, select IC2 When CS1=H, CS2=L, select IC1
17	RES	---	MPU	Reset signal. The LCM can be initialized by setting /RESET=L.
18	NC	---		
19	A(LED+)			Power for backlight (Anode)
20	K(LED-)			Power for backlight (Cathode)

CONFIDENTIAL

7.Contrast adjust

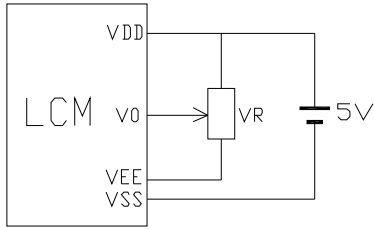

(a) Building DC/DC

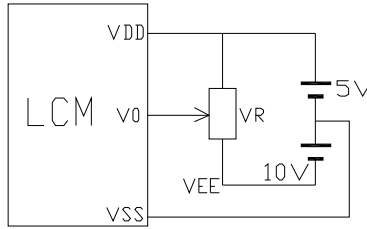

(b) Without DC/DC

V_{DD}-V₀: LCD Driving voltage
VR: 10k~20k

8.Optical characteristics

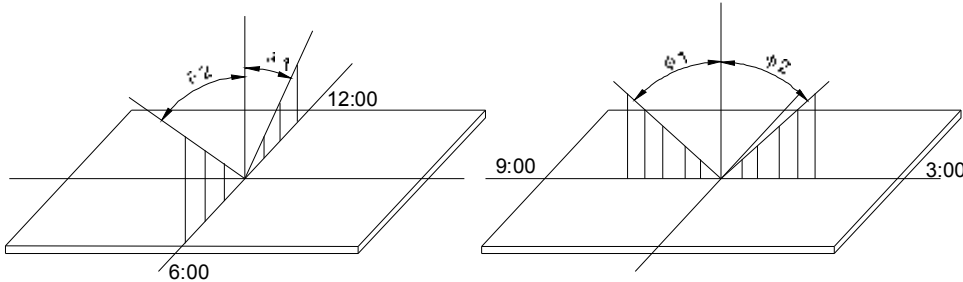

FSTN type display module (Ta=25 ℃, VDD=5.0V)

Item	Symbol	Condition	Min.	Typ.	Max.	Unit
Viewing angle	∅ 1	Cr ≧ 3		40		deg
	∅ 2			20		
	∅ 1			35		
	∅ 2			35		
Contrast ratio	Cr		-	6	-	-
Response time (rise)	Tr	-	-	200	250	ms
Response time (fall)	Tf	-	-	300	350	

9.Electrical characteristics

DC Electrical Characteristics

Parameter	Symbol	Conditions	Min.	Typ.	Max.	Unit
Supply voltage for LCD	V _{DD} -V ₀	Ta = 25 ℃	-	9.5	-	V
Input voltage	V _{DD}		4.7	5.0	5.5	
Supply current	I _{DD}	Ta=25 ℃, V _{DD} =5.0V	-	10	15	mA
Input leakage current	I _{LKG}		-	-	5.0	uA
"H" level input voltage	V _{IH}		2.2	-	V _{DD}	V
"L" level input voltage	V _L	Twice initial value or less	0	-	0.6	
"H" level output voltage	V _{OH}	LOH=-0.25mA	2.4	-	-	
"L" level output voltage	V _{OL}	LOH=1.6mA	-	-	0.4	
Backlight supply current	I _F	V _{DD} =5.0V,R=100ohm	-	20	-	

CONFIDENTIAL

AC CHARACTERISTICS ($V_{DD}=5V + 10\%$, $T_A=-30 \sim +85^{\circ}C$)

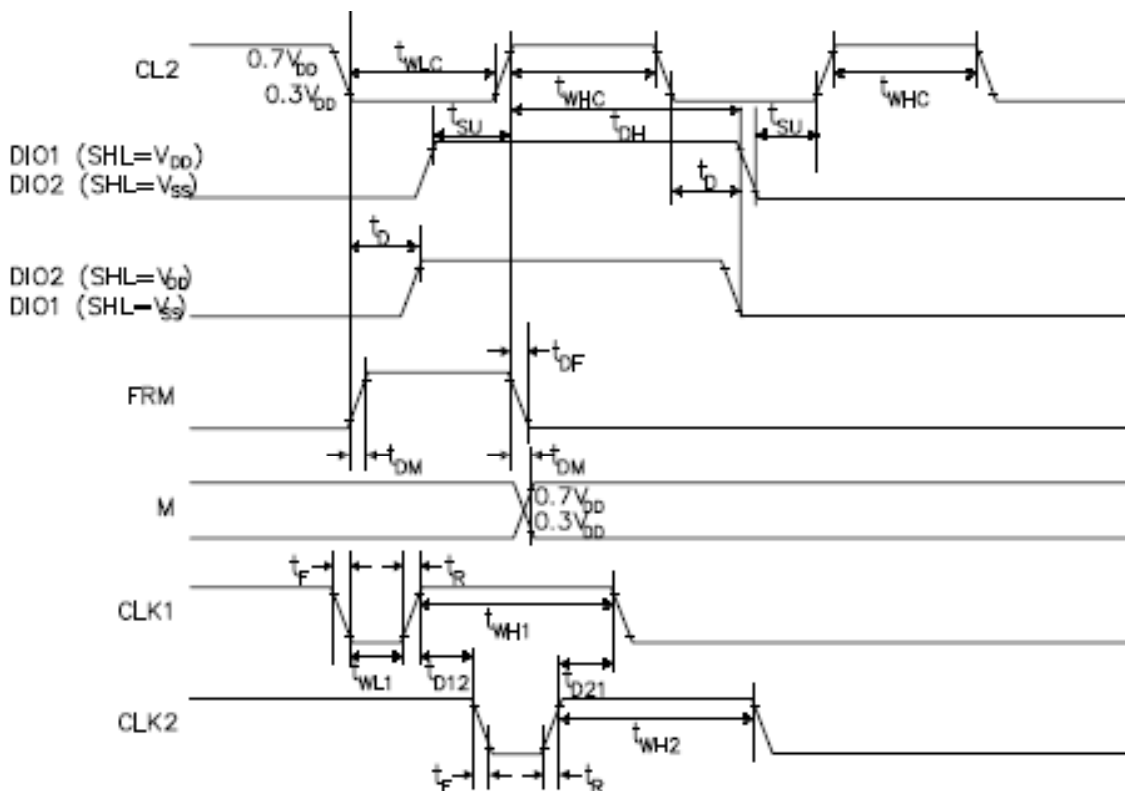

Master Mode

Characteristic	Symbol	Min.	Typ.	Max.	Unit
Data setup time	t _{SU}	20	—	—	μs
Data hold time	t _{DH}	40	—	—	
Data delay time	t _D	5	—	—	
FRM delay time	t _{DF}	-2	—	2	
M delay time	t _{DM}	-2	—	2	
CL2 low level width	t _{WLC}	35	—	—	
CL2 high level width	t _{WHC}	35	—	—	ns
CLK1 low level width	t _{WL1}	700	—	—	
CLK2 low level width	t _{WL2}	700	—	—	
CLK1 high level width	t _{WH1}	2100	—	—	
CLK2 high level width	t _{WH2}	2100	—	—	
CLK1-CLK2 phase difference	t _{D12}	700	—	—	
CLK2-CLK1 phase difference	t _{D21}	700	—	—	
CLK1,CLK2 rise/fall time	t _R /t _F	—	—	150	

9. OPERATING PRINCIPLES & METHODS

Ø I/O Buffer

Input buffer controls the status between the enable and disable of chip. Unless the CS1B to CS3 is in active mode, Input or output of data and instruction does not execute. Therefore internal state is not change. But RSTB and ADC can operate regardless CS1B-CS3.

CONFIDENTIAL

Ø **Input register**

Input register is provided to interface with MPU which is different operating frequency. Input register stores the data temporarily before writing it into display RAM.

When CS1B to CS3 are in the active mode, R/W and RS select the input register. The data from MPU is written into input register. Then writing it into display RAM. Data latched for falling of the E signal and write automatically into the display data RAM by internal operation.

Ø **Output register**

Output register stores the data temporarily from display data RAM when CS1B, CS2B and CS3 are in active mode and R/W and RS=H, stored data in display data RAM is latched in output register. When CS1B to CS3 is in active mode and R/W=H, RS=L, status data (busy check) can read out.

To read the contents of display data RAM, twice access of read instruction is needed. In first access, data in display data RAM is latched into output register. In second access, MPU can read data which is latched. That is to read the data in display data RAM, it needs dummy read. But status read is not needed dummy read.

RS	R/W	Function
L	L	Instruction
	H	Status read (busy check)
H	L	Data write (from input register to display data RAM)
	H	Data read (from display data RAM to output register)

Ø **Reset**

The system can be initialized by setting RSTB terminal at low level when turning power on, receiving instruction from MPU. When RSTB becomes low, following procedure is occurred.

1. Display off
2. Display start line register become set by 0.(Z-address 0)

While RSTB is low, No instruction except status read can be accepted. Therefore, execute other instructions after making sure that DB4= (clear RSTB) and DB7=0 (ready) by status read instruction. The conditions of power supply at initial power up are shown in table 1.

Table 1. Power Supply Initial Conditions

Item	Symbol	Min	Typ	Max	Unit
Reset Time	t_{RS}	1.0	-	-	us
Rise Time	t_R	-	-	200	ns

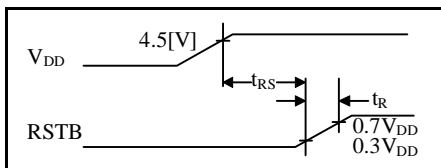

Ø **Busy flag**

Busy flag indicates that NT7108C is operating or no operating. When busy flag is high, NT7108C is in internal operating.

When busy flag is low, NT7108C can accept the data or instruction.

DB7 indicates busy flag of the NT7108C.

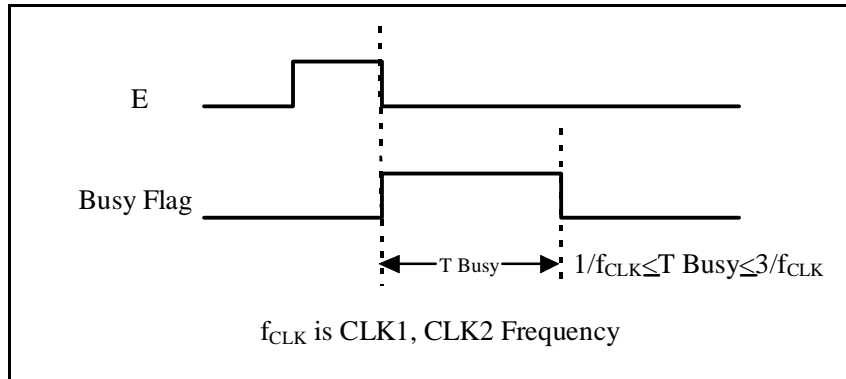

Ø **Display On/Off Flip-Flop**

The display on/off flip-flop makes on/off the liquid crystal display. When flip-flop is reset (logical low), selective voltage or non selective voltage appears on segment output terminals. When flip-flop is set (logic high), non selective voltage appears on segment output terminals regardless of display RAM data. The display on/off flip-flop can change status by instruction. The display data at all segments disappears while RSTB is low.

The status of the flip-flop is output to DB5 by status read instruction.

The display on/off flip-flop is synchronized by CL signal.

Ø **X Page Register**

X page register designates pages of the internal display data RAM.

Count function is not available. An address is set by instruction.

Ø **Y address counter**

Y address counter designates address of the internal display data RAM. An address is set by instruction and is increased by 1 automatically by read or write operations of display data.

Ø **Display Data RAM**

Display data RAM stores a display data for liquid crystal display. To indicate on state dot matrix of liquid crystal display, write data 1. The other way, off state, writes 0.

Display data RAM address and segment output can be controlled by ADC signal.

ADC=H => Y-address 0: S1~Y address 63: S64

ADC=L => Y-address 0: S64~Y address 63: S1

ADC terminal connect the V_{DD} or V_{SS} .

Ø **Display Start Line Register**

The display start line register indicates of display data RAM to display top line of liquid crystal display.

Bit data (DB<0.5>) of the display start line set instruction is latched in display start line register. Latched data is transferred to the Z address counter while FRM is high, presetting the Z address counter.

It is used for scrolling of the liquid crystal display screen.

10. Display Control Instruction

The display control instructions control the internal state of the NT7108C. Instruction is received from MPU to NT7108C for the display control. The following table shows various instructions.

Instruction	RS	RW	DB7	DB6	DB5	DB4	DB3	DB2	DB1	DB0	Function
Read Display Date	1	1	Read data								Reads data (DB[7:0]) from display data RAM to the data bus.
Write Display Date	1	0	Write data								Writes data (DB[7:0]) into the DDRAM. After writing instruction, Y address is incremented by 1 automatically
Status Read	0	1	Bus y	0	ON/OFF	Re-set	0	0	0	0	Reads the internal status BUSY 0: Ready 1: In operation ON/OFF 0: Display ON 1: Display OFF RESET 0: Normal 1: Reset
Set Address (Y address)	0	0	0	1	Y address (0~63)						Sets the Y address at the column address counter
Set Display Start Line	0	0	1	1	Display start line (0~63)						Indicates the Display Data RAM displayed at the top of the screen.
Set Address (X address)	0	0	1	0	1	1	1	Page (0~7)			Sets the X address at the X address register.
Display On/off	0	0	0	0	1	1	1	1	1	0/1	Controls the display ON or OFF. The internal status and the DDRAM data is not affected. 0: OFF, 1: ON

Ø Display On/Off

The display data appears when D is 1 and disappears when D is 0. Though the data is not on the screen with D=0, it remains in the display data RAM. Therefore, you can make it appear by changing D=0 into D=1.

RS	R/W	DB7	DB6	DB5	DB4	DB3	DB2	DB1	DB0
0	0	0	0	1	1	1	1	1	D

Ø Set Address (Y Address)

Y address (AC0~AC5) of the display data RAM is set in the Y address counter. An address is set by instruction and increased by 1 automatically by read or write operations of display data.

RS	R/W	DB7	DB6	DB5	DB4	DB3	DB2	DB1	DB0
0	0	0	1	AC5	AC4	AC3	AC2	AC1	AC0

Ø Set Page (X Address)

X address (AC0~AC2) of the display data RAM is set in the X address register.
 Writing or reading to or from MPU is executed in this specified page until the next page is set.

RS	R/W	DB7	DB6	DB5	DB4	DB3	DB2	DB1	DB0
0	0	1	0	1	1	1	AC2	AC1	AC0

Ø Display Start Line (Z Address)

Z address (AC0~AC5) of the display data RAM is set in the display start line register and displayed at the top of the screen.

When the display duty cycle is 1/64 or others (1/32~1/64), the data of total line number of LCD screen, from the line specified by display start line instruction, is displayed.

RS	R/W	DB7	DB6	DB5	DB4	DB3	DB2	DB1	DB0
0	0	1	1	AC5	AC4	AC3	AC2	AC1	AC0

Ø Status Read

RS	R/W	DB7	DB6	DB5	DB4	DB3	DB2	DB1	DB0
1	0	BUS Y	0	ON/OFF	RESET	0	0	0	0

I BUSY

When BUSY is 1, the Chip is executing internal operation and no instructions are accepted.
 When BUSY is 0, the Chip is ready to accept any instructions.

I ON/OFF

When ON/OFF is 1, the display is on.
 When ON/OFF is 0, the display is off.

I RESET

When RESET is 1, the system is being initialized.
 In this condition, no instructions except status read can be accepted.
 When RESET is 0, initializing has finished and the system is in the usual operation condition.

Ø Write Display Data

Writes data (D0~D7) into the display data RAM.
 After writing instruction, Y address is increased by 1 automatically.

RS	R/W	DB7	DB6	DB5	DB4	DB3	DB2	DB1	DB0
1	0	D7	D6	D5	D4	D3	D2	D1	D0

Ø Read Display Data

Reads data (D0~D7) from the display data RAM.
 After reading instruction, Y address is increased by 1 automatically.

RS	R/W	DB7	DB6	DB5	DB4	DB3	DB2	DB1	DB0
1	1	D7	D6	D5	D4	D3	D2	D1	D0

11. Quality Specifications

11.1 STANDARD OF THE PRODUCT APPEARANCE TEST

Manner of appearance test: The inspection should be performed in using 20W x 2 fluorescent lamps. Distance between LCM and fluorescent lamps should be 100 cm or more. Distance between LCM and inspector eyes should be 25 cm or more.

Viewing direction for inspection is 35° from vertical against LCM.

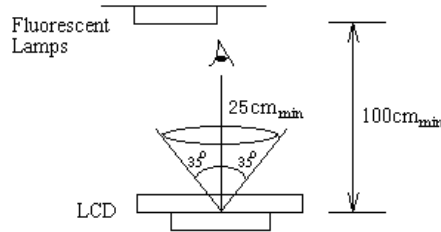

Definition of LCM

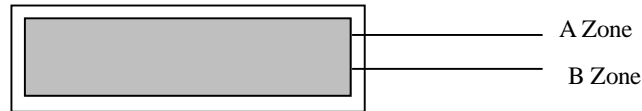

A Zone: Active display area (minimum viewing area).

B Zone: Non-active display area (outside viewing area).

11.2 SPECIFICATION OF QUALITY ASSURANCE

AQL inspection standard

Sampling method: GB2828-87, Level II, single sampling

Defect classification (**Note: * is not including**)

Classify		Item	Note	AQL	
Major	Display state	Short or open circuit	1	0.65	
		LC leakage			
		Flickering			
		No display			
		Wrong viewing direction			
		Contrast defect (dim, ghost)			2
		Backlight			1,8
	Non-display	Flat cable or pin reverse	10		
	Wrong or missing component	11			
Minor	Display state	Background color deviation	2	1.0	
		Black spot and dust	3		
		Line defect, Scratch	4		
		Rainbow	5		
		Chip	6		
		Pin hole	7		
		Protruded	12		
	Polarizer	Bubble and foreign material	3		
	Soldering	Poor connection	9		
	Wire	Poor connection	10		
	TAB	Position, Bonding strength	13		

CONFIDENTIAL

Note on defect classification

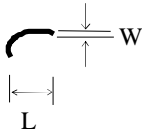
No.	Item	Criterion													
1	Short or open circuit	Not allow													
	LC leakage														
	Flickering														
	No display														
	Wrong viewing direction														
	Wrong Back-light														
2	Contrast defect	Refer to approval sample													
	Background color deviation														
3	Point defect, Black spot, dust (including Polarizer) $\phi = (X+Y)/2$	 <table border="1" data-bbox="870 793 1252 1012"> <thead> <tr> <th>Point Size</th> <th>Acceptable Qty.</th> </tr> </thead> <tbody> <tr> <td>$\phi \leq 0.10$</td> <td>Disregard</td> </tr> <tr> <td>$0.10 < \phi \leq 0.15$</td> <td>2</td> </tr> <tr> <td>$0.15 < \phi \leq 0.25$</td> <td>1</td> </tr> <tr> <td>$\phi > 0.25$</td> <td>0</td> </tr> </tbody> </table> <p style="text-align: center;">Unit; Inch²</p>	Point Size	Acceptable Qty.	$\phi \leq 0.10$	Disregard	$0.10 < \phi \leq 0.15$	2	$0.15 < \phi \leq 0.25$	1	$\phi > 0.25$	0			
Point Size	Acceptable Qty.														
$\phi \leq 0.10$	Disregard														
$0.10 < \phi \leq 0.15$	2														
$0.15 < \phi \leq 0.25$	1														
$\phi > 0.25$	0														
4	Line defect, Scratch	 <table border="1" data-bbox="808 1213 1289 1373"> <thead> <tr> <th colspan="2">Line</th> <th>Acceptable Qty.</th> </tr> <tr> <th>L</th> <th>W</th> <th></th> </tr> </thead> <tbody> <tr> <td>---</td> <td>$0.05 > W$</td> <td rowspan="3">Disregard</td> </tr> <tr> <td>$3.0 > L$</td> <td>$0.1 > W > 0.05$</td> </tr> <tr> <td>$2.0 > L$</td> <td>$0.15 \geq W > 0.1$</td> </tr> </tbody> </table> <p style="text-align: center;">Unit: mm</p>	Line		Acceptable Qty.	L	W		---	$0.05 > W$	Disregard	$3.0 > L$	$0.1 > W > 0.05$	$2.0 > L$	$0.15 \geq W > 0.1$
Line		Acceptable Qty.													
L	W														
---	$0.05 > W$	Disregard													
$3.0 > L$	$0.1 > W > 0.05$														
$2.0 > L$	$0.15 \geq W > 0.1$														
5	Rainbow	Not more than two color changes across the viewing area.													

CONFIDENTIAL

No	Item	Criterion
----	------	-----------

CONFIDENTIAL

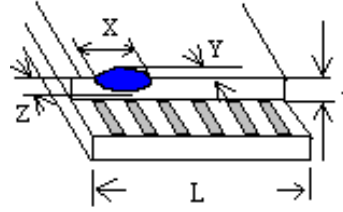
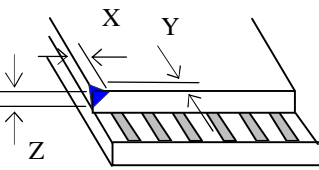
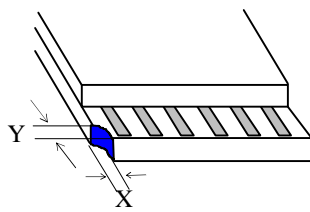
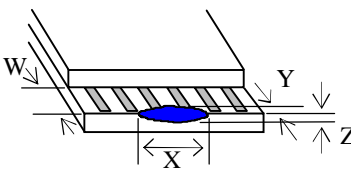
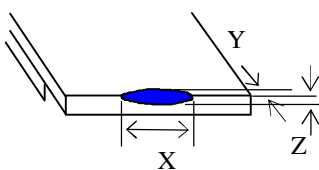
<p>6 Chip</p> <p>Remark: X: Length direction Y: Short direction Z: Thickness direction t: Glass thickness W: Terminal width L: Glass length</p>		<p>Acceptable criterion</p> <table border="1" style="width: 100%; border-collapse: collapse; text-align: center;"> <tr> <th>X</th> <th>Y</th> <th>Z</th> </tr> <tr> <td>$< L/8$</td> <td>0.5mm</td> <td>$\leq t/2$</td> </tr> </table>	X	Y	Z	$< L/8$	0.5mm	$\leq t/2$			
X	Y	Z									
$< L/8$	0.5mm	$\leq t/2$									
		<p>Acceptable criterion</p> <table border="1" style="width: 100%; border-collapse: collapse; text-align: center;"> <tr> <th>X</th> <th>Y</th> <th>Z</th> </tr> <tr> <td>≤ 2</td> <td>0.5mm</td> <td>$\leq t$</td> </tr> </table>	X	Y	Z	≤ 2	0.5mm	$\leq t$			
X	Y	Z									
≤ 2	0.5mm	$\leq t$									
		<p>Acceptable criterion</p> <table border="1" style="width: 100%; border-collapse: collapse; text-align: center;"> <tr> <th>X</th> <th>Y</th> <th>Z</th> </tr> <tr> <td>≤ 3</td> <td>≤ 2</td> <td>$\leq t$</td> </tr> <tr> <td colspan="2">shall not reach to ITO</td> <td></td> </tr> </table>	X	Y	Z	≤ 3	≤ 2	$\leq t$	shall not reach to ITO		
X	Y	Z									
≤ 3	≤ 2	$\leq t$									
shall not reach to ITO											
		<p>Acceptable criterion</p> <table border="1" style="width: 100%; border-collapse: collapse; text-align: center;"> <tr> <th>X</th> <th>Y</th> <th>Z</th> </tr> <tr> <td>Disregard</td> <td>≤ 0.2</td> <td>$\leq t$</td> </tr> </table>	X	Y	Z	Disregard	≤ 0.2	$\leq t$			
X	Y	Z									
Disregard	≤ 0.2	$\leq t$									
		<p>Acceptable criterion</p> <table border="1" style="width: 100%; border-collapse: collapse; text-align: center;"> <tr> <th>X</th> <th>Y</th> <th>Z</th> </tr> <tr> <td>≤ 5</td> <td>≤ 2</td> <td>$\leq t/3$</td> </tr> </table>	X	Y	Z	≤ 5	≤ 2	$\leq t/3$			
X	Y	Z									
≤ 5	≤ 2	$\leq t/3$									

No.	Item	Criterion
7	Segment	(1) Pin hole

CONFIDENTIAL

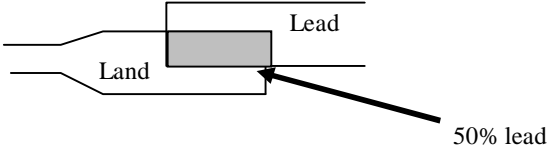
	<p>pattern W = Segment width $\phi = (X+Y)/2$</p>	<p>$\phi < 0.10\text{mm}$ is acceptable.</p>
8	Back-light	<p>(1) The color of backlight should be in match with the specification. (2) Not allow flickering</p>
9	Soldering	<p>(1) Not allow heavy dirty and solder ball on PCB. (The size of dirty refer to point and dust defect) (2) Over 50% of lead should be soldered on Land.</p> 
10	Wire	<p>(1) Copper wire should not be rusted (2) Not allow crack on copper wire connection. (3) Not allow reversing the position of the flat cable. (4) Not allow exposed copper wire inside the flat cable.</p>
11*	PCB	<p>(1) Not allow screw rust or damage. (2) Not allow missing or wrong putting of component.</p>

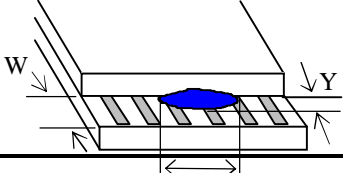
No	Item	Criterion
12	<p>Protruded W: Terminal Width</p>	 <p>Acceptable criteria: $Y \leq 0.4$</p>

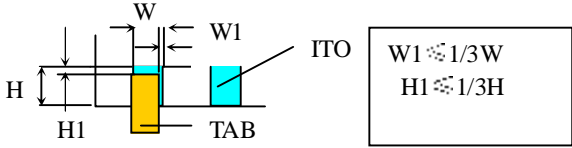
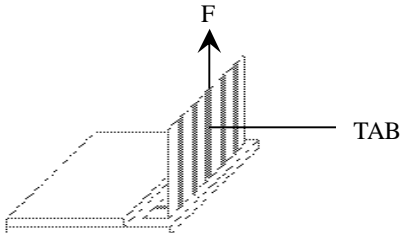
13	TAB	<p>1. Position</p>  <p>2. TAB bonding strength test</p>  <p>$P (=F/TAB \text{ bonding width}) \geq 650\text{gf/cm}$, (speed rate: 1mm/min) 5pcs per SOA (shipment)</p>
14	Total no. of acceptable Defect	<p>A. Zone</p> <p>Maximum 2 minor non-conformities per one unit.</p> <p>Defect distance: each point to be separated over 10mm</p> <p>B. Zone</p> <p>It is acceptable when it is no trouble for quality and assembly in customer's end product.</p>

11.3 RELIABILITY OF LCM

Reliability test condition:

Item	Condition	Time (hrs)	Assessment
High temp. Storage	80°C	48	No abnormalities in functions
High temp. Operating	70°C	48	
Low temp. Storage	-30°C	48	

Low temp. Operating	-20°C	48	
Humidity	40°C/ 90%RH	48	
Temp. Cycle	0°C ← 25°C → 50°C (30 min ← 5 min → 30min)	10cycles	

Recovery time should be 24 hours minimum. Moreover, functions, performance and appearance shall be free from remarkable deterioration within 50,000 hours under ordinary operating and storage conditions room temperature (20±8°C), normal humidity (below 65% RH), and in the area not exposed to direct sun light.

11.4 PRECAUTION FOR USING LCD/LCM

LCD/LCM is assembled and adjusted with a high degree of precision. Do not attempt to make any alteration or modification. The followings should be noted.

GENERAL PRECAUTIONS:

1. LCD panel is made of glass. Avoid excessive mechanical shock or applying strong pressure onto the surface of display area.
2. The polarizer used on the display surface is easily scratched and damaged. Extreme care should be taken when handling. To clean dust or dirt off the display surface, wipe gently with cotton, or other soft material soaked with isopropyl alcohol, ethyl alcohol or trichlorotrifluoroethane, do not use water, ketone or aromatics and never scrub hard.
3. Do not tamper in any way with the tabs on the metal frame.
4. Do not make any modification on the PCB without consulting USMP
5. When mounting a LCM, make sure that the PCB is not under any stress such as bending or twisting. Elastomer contacts are very delicate and missing pixels could result from slight dislocation of any of the elements.
6. Avoid pressing on the metal bezel, otherwise the elastomer connector could be deformed and lose contact, resulting in missing pixels and also cause rainbow on the display.
7. Be careful not to touch or swallow liquid crystal that might leak from a damaged cell. Any liquid crystal spreads to skin or clothes, wash it off immediately with soap and water.

STATIC ELECTRICITY PRECAUTIONS:

1. CMOS-LSI is used for the module circuit; therefore operators should be grounded whenever he/she comes into contact with the module.
2. Do not touch any of the conductive parts such as the LSI pads; the copper leads on the PCB and the interface terminals with any parts of the human body.
3. Do not touch the connection terminals of the display with bare hand; it will cause disconnection or defective insulation of terminals.
4. The modules should be kept in anti-static bags or other containers resistant to static for storage.
5. Only properly grounded soldering irons should be used.
6. If an electric screwdriver is used, it should be grounded and shielded to prevent sparks.
7. The normal static prevention measures should be observed for work clothes and working benches.
8. Since dry air is inductive to static, a relative humidity of 50-60% is recommended.

SOLDERING PRECAUTIONS:

CONFIDENTIAL

1. Soldering should be performed only on the I/O terminals
2. Use soldering irons with proper grounding and no leakage.
3. Soldering temperature: $280^{\circ}\text{C}\pm 10^{\circ}\text{C}$
4. Soldering time: 3 to 4 second.
5. Use eutectic solder with resin flux filling.
6. If flux is used, the LCD surface should be protected to avoid spattering flux.
7. Flux residue should be removed.

OPERATION PRECAUTIONS:

1. The viewing angle can be adjusted by varying the LCD driving voltage V_o .
2. Since applied DC voltage causes electro-chemical reactions, which deteriorate the display, the applied pulse waveform should be a symmetric waveform such that no DC component remains. Be sure to use the specified operating voltage.
3. Driving voltage should be kept within specified range; excess voltage will shorten display life.
4. Response time increases with decrease in temperature.
5. Display color may be affected at temperatures above its operational range.
6. Keep the temperature within the specified range usage and storage. Excessive temperature and humidity could cause polarization degradation, polarizer peel-off or generate bubbles.
7. For long-term storage over 40°C is required, the relative humidity should be kept below 60%, and avoid direct sunlight.

CONFIDENTIAL



US Micro Products

Electronic Products for the OEM

Los Angeles • Austin • New York • Orlando • Shenzhen

(800) 741-7755

www.usmicroproducts.com

Displays

US Micro Products is an industrial distributor specializing in engineered display solutions. We dedicate ourselves to providing the best in displays for the medical, industrial, gaming, automotive, aerospace, military, and consumer markets.

OLEDs



TFT Displays



Open Frame Monitors



Passive LCDs



Multitouch



As a customer, you benefit from our expert knowledge, support and service which allow quick selection and design-in of the best display for your application. On hand stock and demo boards facilitate quick access and evaluation to get you going fast. Our technical sales staff and experienced design engineers provide answers to your questions as well as engineered solutions to solve your display needs.

Peripheral Devices

Our full line of peripheral devices includes keyboards, trackballs, and printers. These rugged industrial products are designed to meet your demanding requirements and are available as both standard and custom solutions.

Keyboards



Trackballs



Aerospace Trackballs



Joysticks



Printers

