

TFT SPECIFICATION

Part Number	USMP-T123-192072NBQ-A0
Size	12.3"
Resolution	1920 x 720
Brightness	750 cd/m ²
Contrast	1000:1
Viewing Angle	85/85/85/85
Operating Temp.	-30 ~ 85°C

FOR ADDITIONAL INFORMATION
PLEASE CONTACT:
engineering@usmicroproducts.com

Issue Date	Approved by (customer use)	Checked by	Prepared by

PROPRIETARY NOTE: THIS SPECIFICATION IS THE PROPERTY OF US MICRO PRODUCTS AND SHALL NOT BE REPRODUCED OR COPIED WITHOUT THE WRITTEN PERMISSION OF US MICRO PRODUCTS AND MUST BE RETURNED TO US MICRO PRODUCTS UPON ITS REQUEST.

(800) 741-7755
www.usmicroproducts.com

REVISION HISTORY

Version	Date	Page	Description
0.0	Nov,11, 2015	All	Spec Ver.0.0 was first issued.
0.1	May, 11, 2016	1, 5, 12, 17, 20, 22	Page 1: Revise General Specifications; Page 5: Revise Backlight Driving Conditions; Page 13: Revise Optical Specifications; Page 17: Reliability Test Items; Page 20: Mechanical Drawing; Page 22: add Packing Drawing
0.2	Aug., 15, 2016	1, 4, 5, 6, 7, 10, 13	Page1: Revise General Specifications; Page4: Absolute Maximum Rating; Page5: Typical Operation Conditions; Backlight Driving Conditions; Page6: PWM; Page7: Power Sequence; Page10: Timing; Page13: Revise Optical Specifications
0.3	Oct., 5, 2016	1, 5, 7, 13, 21, 22, 24, 25	Page1: General Specifications Page5: Typical Operation Conditions Page7: Power Sequence Page13: Optical Specifications Page21, 22: Mechanical Drawing Page24, 25: Packaging drawing and shipping drawing
0.4	Oct., 19, 2016	1, 4, 5, 6, 12, 17, 20	Page1: General Specifications Page4: Absolute Maximum Rating Page5: Typical Operation Conditions & Backlight Driving Conditions Page6: Thermal Simulation Page12: Reset timing Page17: Reliability Test Items Page20: Mechanical Drawing
0.5	Dec.02.2016	1,2,	Page1: General Specifications Page 2: Connector Type
0.6	Jun.15.2017	1,5,6	Page1: General Specifications Page5: Typical Operation Conditions Page6: Backlight Driving Conditions

Contents

1	General Specifications.....	1
2	Pin Assignment.....	2
3	Operation Specifications.....	4
	3.1 Absolute Maximum Rating.....	4
	3.1.1 Typical Operation Conditions.....	5
	3.1.2 Backlight Driving Conditions.....	6
	3.1.3 PWM.....	6
	3.2 Power Sequence.....	7
	3.2.1 Power On.....	7
	3.2.2 Power Off.....	7
	3.3 Timing Characteristics.....	8
	3.3.1 AC Electrical Characteristics.....	8
	3.3.2 Input Clock and Data Timing Diagram.....	8
	3.3.3 DC Electrical Characteristics.....	10
	3.3.4 Timing.....	10
	3.3.5 Data Input Format.....	11
	3.3.6 Reset Timing.....	12
4	Optical Specifications.....	13
5	Reliability Test Items.....	17
6	General Precautions.....	19
	6.1 Safety.....	19
	6.2 Handling	19
	6.3 Static Electricity.....	19
	6.4 Storage.....	19
	6.5 Cleaning.....	19
7	Mechanical Drawing.....	20
8	Package Drawing.....	21
	8.1 Packaging Material Table.....	21
	8.2 Packaging Quantity.....	21
	8.3 Packaging Drawing.....	22
	8.4 Shipping Drawing.....	23

1. General Specifications

No.	Item	Specification	Remark
1	LCD Size	12.3 inch (Diagonal)	
2	Driver Element	a-Si TFT Active Matrix	
3	Resolution	1920 X 3(RGB) X 720	
4	Display Mode	Normally Black, Transmissive	
5	Dot Pitch	0.0508 x 0.1524	
6	Active Area	292.608(W) X 109.728(H) mm	
7	Module Size	310(W) X 129.1(H) X 7.5(D) mm	Note 1
8	Bezel Opening Size	295.61(W) X 112.73(H) mm	
9	Surface Treatment	Anti-Glare	
10	Color Arrangement	RGB-Stripe	
11	Interface	2 Port LVDS(DE Only)	
12	Backlight Power Consumption	8.2W(TYP.)	
13	Panel Power Consumption	0.86W(TYP.)	
14	Weight	463g (MAX.)	
15	NTSC	85%	

Note 1: Refer to Mechanical Drawing.

2. Pin Assignment

Connector on PCB is used for the module electronics interface. The recommended model is 12003S-50Y900 manufactured by IRISO.

Connector type : IRISO 12003S-50Y900					
Pin	Input signal name	I/O pin (I:input, O:output, P:power)	Typical voltage (Volt)		description
1	GND	P	0.00 V	power supply	Ground
2	VDD	P	3.3 V	power supply	External main and I/O power supply ; Power3V3
3	VDD	P	3.3 V	power supply	External main and I/O power supply : Power3V3
4	VDD	P	3.3 V	power supply	External main and I/O power supply ; Power3V3
5	RESET	I	3.3V or 0V	Function	Global reset pin (Default high), active low.
6	STBYB	I	3.3V or 0V	Function	Standby mode setting pin (Default high), active low.
7	GND	P	0.00 V	power supply	Ground
8	OLV0N	I		LVDS signal	LVDS odd data 0-
9	OLV0P	I		LVDS signal	LVDS odd data 0+
10	GND	P	0.00 V	power supply	Ground
11	OLV1N	I		LVDS signal	LVDS odd data 1-
12	OLV1P	I		LVDS signal	LVDS odd data 1+
13	GND	P	0.00 V	power supply	Ground
14	OLV2N	I		LVDS signal	LVDS odd data 2-
15	OLV2P	I		LVDS signal	LVDS odd data 2+
16	GND	P	0.00 V	power supply	Ground
17	OLVCLKN	I		LVDS signal	LVDS odd clk -
18	OLVCLKP	I		LVDS signal	LVDS odd clk +
19	GND	P	0.00 V	power supply	Ground
20	OLV3N	I		LVDS signal	LVDS odd data 3-
21	OLV3P	I		LVDS signal	LVDS odd data 3+
22	GND	P	0.00 V	power supply	Ground
23	ELV0N	I		LVDS signal	LVDS even data 0-
24	ELV0P	I		LVDS signal	LVDS even data 0+
25	GND	P	0.00 V	power supply	Ground
26	ELV1N	I		LVDS signal	LVDS even data 1-
27	ELV1P	I		LVDS signal	LVDS even data 1+
28	GND	P	0.00 V	power supply	Ground
29	ELV2N	I		LVDS signal	LVDS even data 2-
30	ELV2P	I		LVDS signal	LVDS even data 2+
31	GND	P	0.00 V	power supply	Ground
32	ELVCLKN	I		LVDS signal	LVDS even clk -
33	ELVCLKP	I		LVDS signal	LVDS even clk +
34	GND	P	0.00 V	power supply	Ground
35	ELV3N	I		LVDS signal	LVDS even data 3-
36	ELV3P	I		LVDS signal	LVDS even data 3+
37	GND	P	0.00 V	power supply	Ground
38	GND	P	0.00 V	power supply	Ground

39	RL	I	3.3V or 0V	Function	Horizontal shift direction (source output) selection. RL = 1: Left -> Right(default: Customer to Pull high, internal IC Pull high*) RL = 0: Right -> Left
40	TB	I	3.3V or 0V	Function	Vertical shift direction (gate output) selection. TB = 0: Bottom->Top TB = 1: Top ->Bottom (default: Customer to Pull high, internal IC Pull high*)
41	VDD	P	3.3 V	power supply	External main and I/O power supply ; Power3V3
42	GND	I	0.00 V	power supply	LCD Maker Internal Use
43	GND	I	0.00 V	power supply	LCD Maker Internal Use
44	VDD	P	3.3 V	power supply	External main and I/O power supply ; Power3V3
45	NC				Keep floating
46	NC				Keep floating
47	NC				Keep floating
48	NC				Keep floating
49	NC				Keep floating
50	NC				Keep floating

The recommended model of FPC Connector is 12001S-10Y901 manufactured by IRISO

Connector type : IRISO IMSA-12001S-10Y901			
PIN No.	Symbol	I/O	Function
1	PLED	Power	LED anode power supply
2	PLED	Power	LED anode power supply
3	PLED	Power	LED anode power supply
4	NC		
5	NTC1		heat sensor
6	NTC2(GND)		heat sensor
7	NLED	Power	LED cathode power supply
8	NLED	Power	LED cathode power supply
9	NLED	Power	LED cathode power supply
10	NLED	Power	LED cathode power supply

Note: Definition of scanning direction.
Refer to the figure as below:

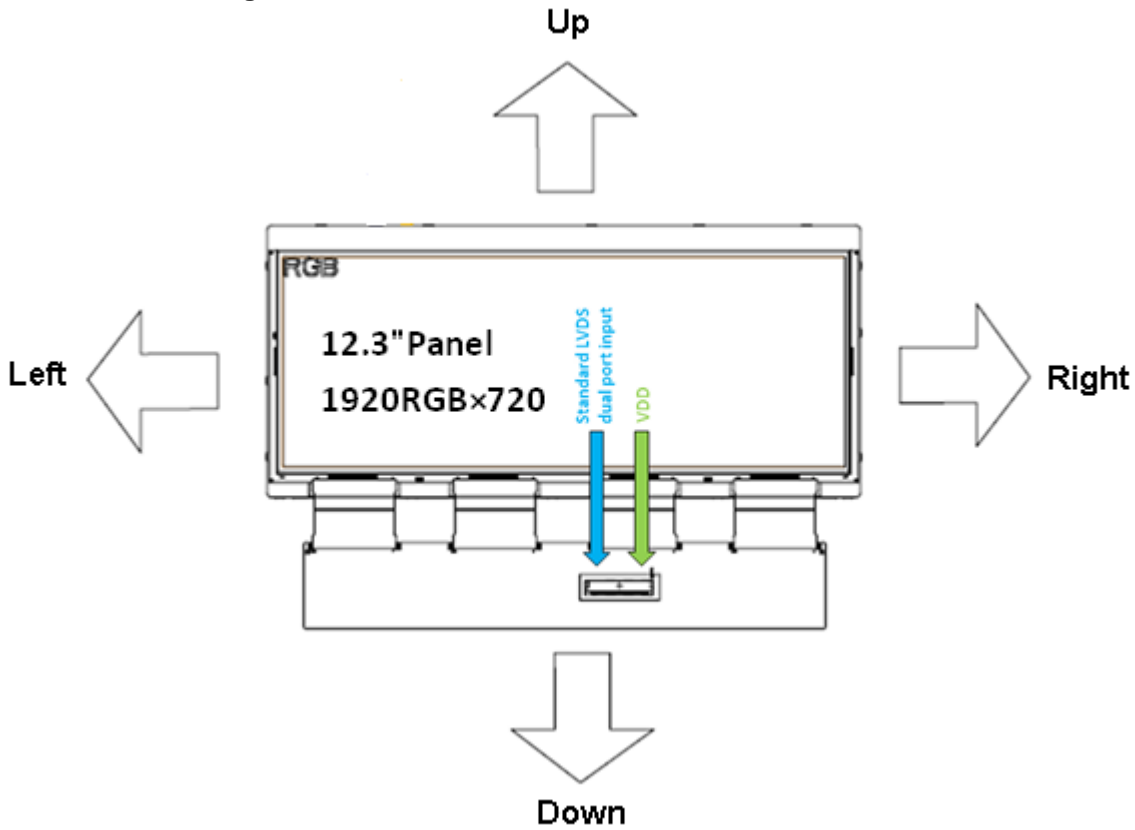

3. Operation Specifications

3.1. Absolute Maximum Rating

(GND=0V, Note 1)

Item	Symbol	Values		Unit	Remark
		Min.	Max.		
Power Voltage	V _{DD}	-0.3	(3.96)	V	Note 1
Operation Temperature	T _{OP}	-30	85	°C	Note2, 3, 4
Storage Temperature	T _{ST}	-40	90	°C	Note2, 3

Note 1 : The absolute maximum rating values of this product are not allowed to be exceeded at any times. Should a module be used with any of the absolute maximum ratings exceeded, the characteristics of the module may not be recovered, or in an extreme case, the module may be permanently destroyed.

Note 2 : This rating applies to all parts of the module and should not be exceeded.

Note 3 : Maximum wet-bulb temperature is 58°C. Condensation of dew must be avoided as electrical current leaks will occur, causing a degradation of performance specifications.

Note 4 : The operating temperature only guarantees operation of the LCM and doesn't guarantee all the contents of Electro-optical specification.

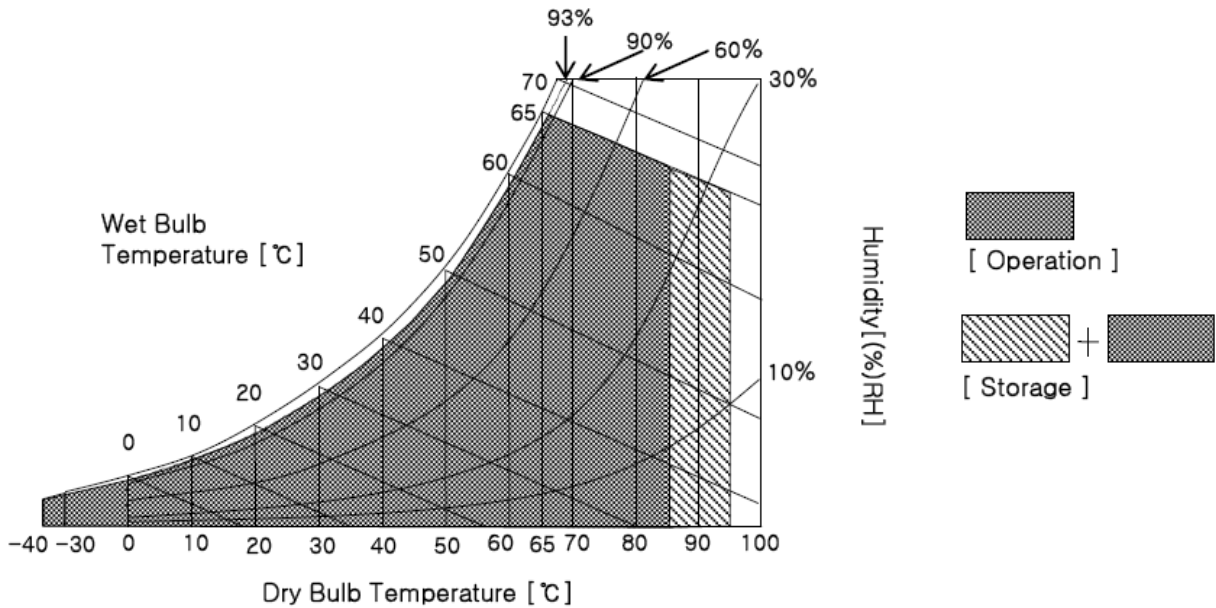

3.1.1 Typical Operation Conditions

(GND =0V)

Item	Symbol	Values			Unit	Remark
		Min.	Typ.	Max.		
Power voltage	V_{DD}	3.1	3.3	3.6	V	Note 1,2
Power Supply Input Current	I_{DD}	210	260	310	mA	Note 3
Input logic high voltage	V_{IH}	$0.7 V_{DD}$	-	V_{DD}	V	Note 4
Input logic low voltage	V_{IL}	GND	-	$0.3 V_{DD}$	V	
Pull low / high resistor	RI	125	250	375	kΩ	For I/O circuit

Note 1: V_{DD} setting should match the signals output voltage of customer's system board.

Note 2: The ripple voltage should be controlled under 5% of V_{DD}

Note 3: Full white pattern.

Note 4: RESET, STBYB , RL, TB

3.1.2 Backlight Driving Conditions

Item	Symbol	Values			Unit	Remark
		Min.	Typ.	Max.		
Voltage for LED Backlight	V _L	33.6	37.2	39.6	V	Note 1
Current for LED Backlight	I _L		220		mA	
LED Life Time	-	30000			Hr	Note 2

Note 1: The LED Supply Voltage is defined by the number of LED at Ta=25°C and I_F =150mA.

Note 2: The “LED life time” is defined as the module brightness decrease to 50% original brightness at Ta=25°C and I_L = 220mA. The LED lifetime could be decreased if operating I_L is larger than 220 mA.

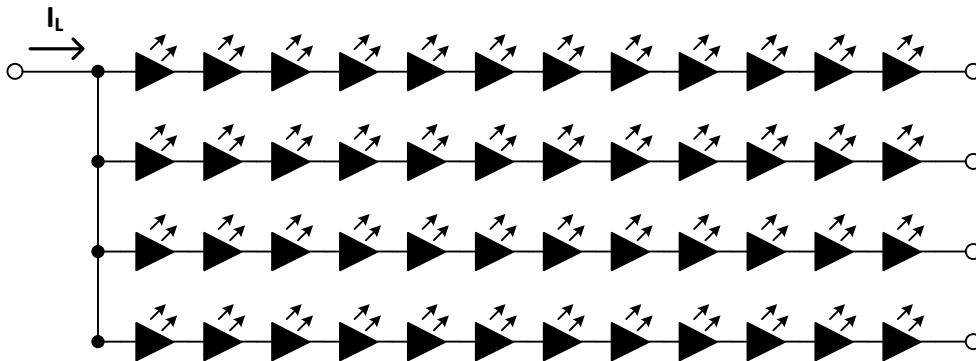

3.1.3 PWM

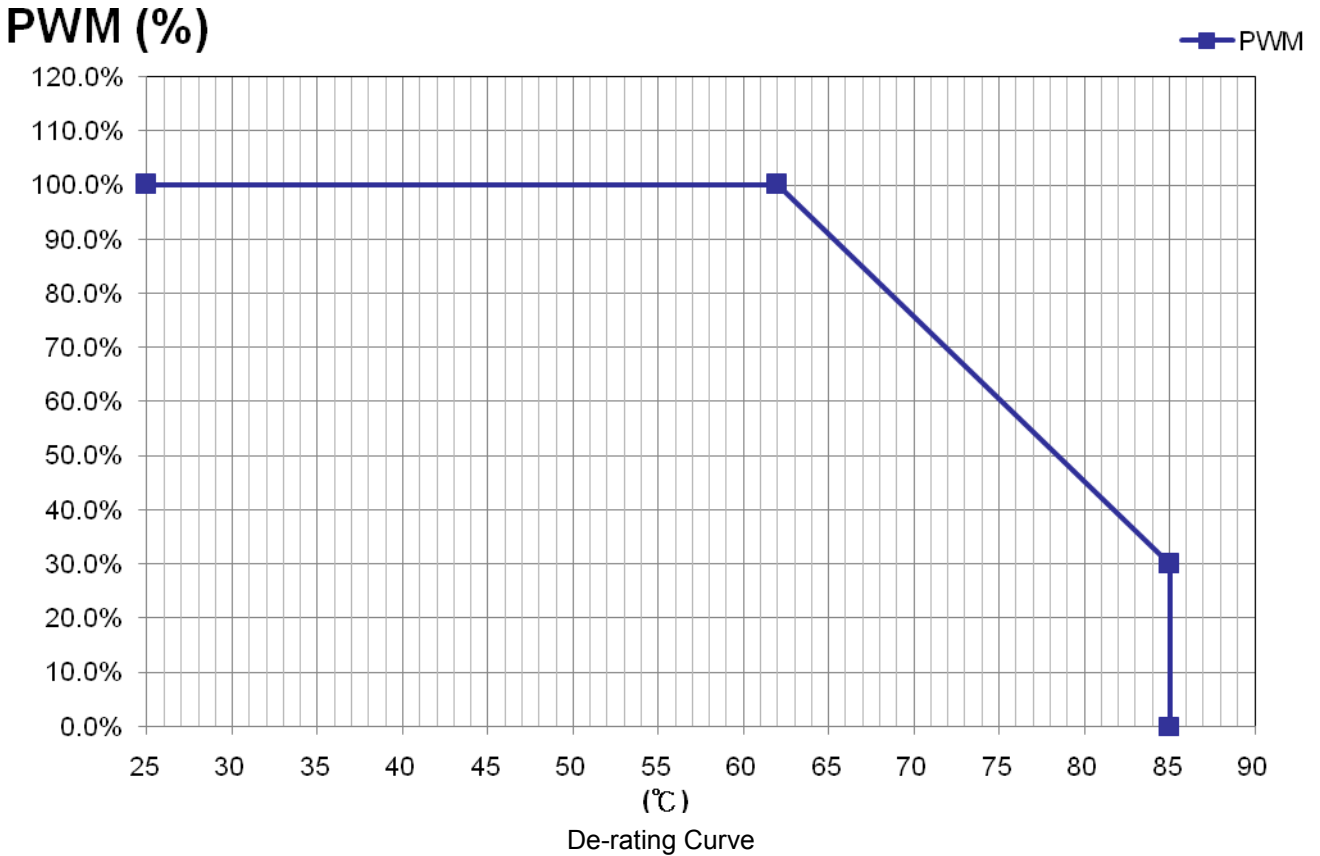

Thermistor P/N: NCU15XH103F6SRC

Thermal Simulation

1. After several condition comparison, we will use the LED with metalcore PCB + Heat-sink for this case.
2. 48pcs LEDs with total 8.2W
3. The optical film will be the first to reach the material limit.
4. By simulation result, we need to start to de-rating the BLU from 62 degree C to protect the material safe.

3.2. Power Sequence

VDD = 3.0~3.6V

3.2.1 Power on:

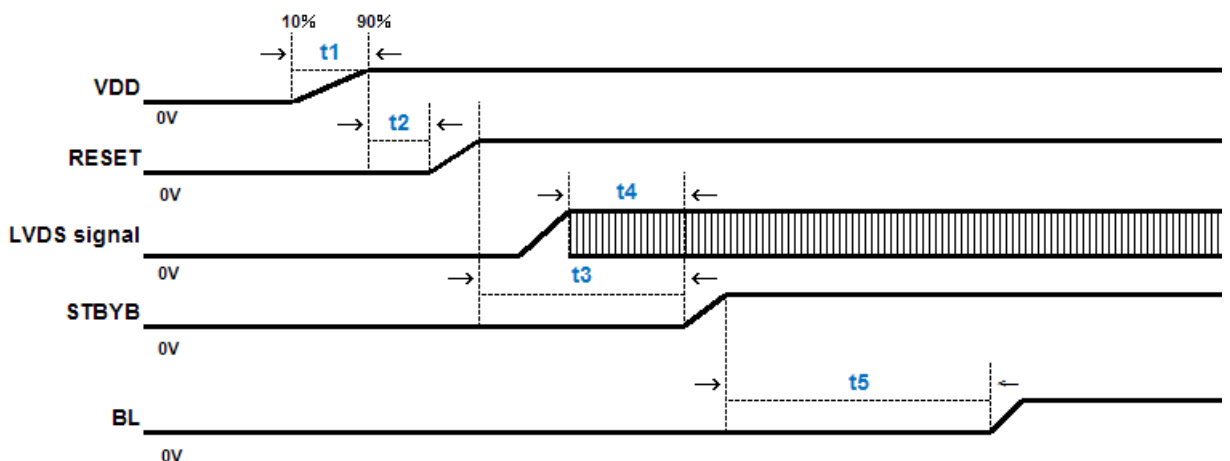

3.2.2 Power off:

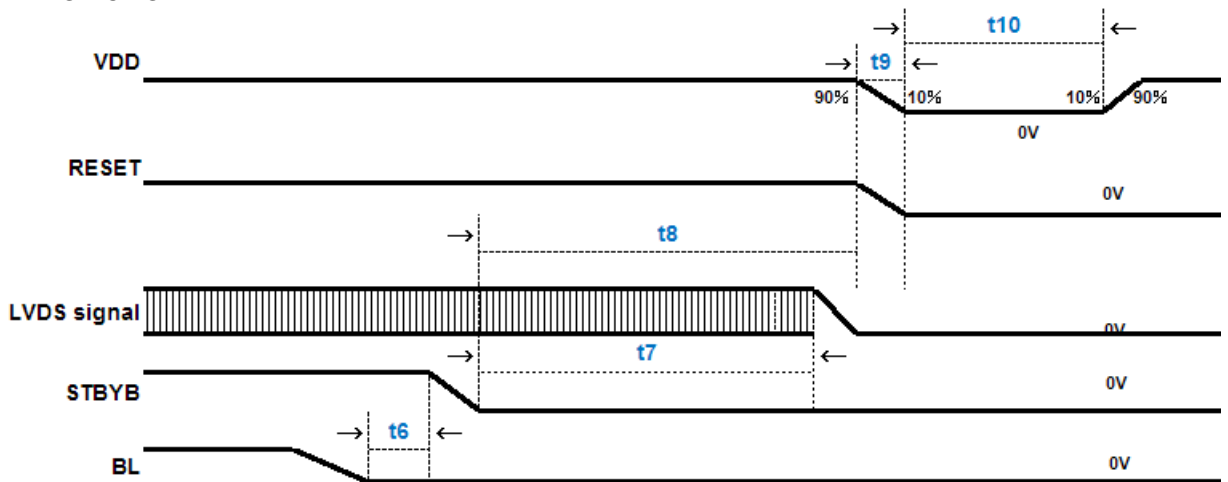

Symbol	SPEC.			Unit
	Min.	Typ.	Max.	
t1	1.5	2	3	ms
t2	1.0	5	10	ms
t3	0	30	50	ms
t4	0	5	10	ms
t5	10	12	15	frame
t6	0	25	50	ms
t7	7	9	10	frame
t8	8	10	11	frame
t9	0	1	3	ms
t10	1000	2000	3000	ms

3.3. Timing Characteristics

3.3.1. AC Electrical Characteristics

Parameter	Symbol	Spec.			Unit	Remark
		Min.	Typ.	Max.		
Clock frequency	FLVCYC	20	-	85	MHz	Frame rate=60Hz
Clock Period	TLVCYC	11.76	-	50	Nsec	Frame rate=60Hz
1 data bit time	UI	-	1/7	-	TLVCYC	
Position 1	TPOS1	-0.2	0	0.2	UI	Note9
Position 0	TPOS0	0.8	1	1.2	UI	
Position 6	TPOS6	1.8	2	2.2	UI	
Position 5	TPOS5	2.8	3	3.2	UI	
Position 4	TPOS4	3.8	4	4.2	UI	
Position 3	TPOS3	4.8	5	5.2	UI	

Position 2	TPOS2	5.8	6	6.2	UI
Input eye width	TEYEW	0.6	-	-	UI
Input eye border	TEX	-	-	0.2	UI
LVDS wake up time	TENLVDS	-	-	150	ns

Note9 : Please refer to “3.3.2 Input Clock and Data Timing Diagram”

3.3.2. Input Clock and Data Timing Diagram

LVDS input timing:

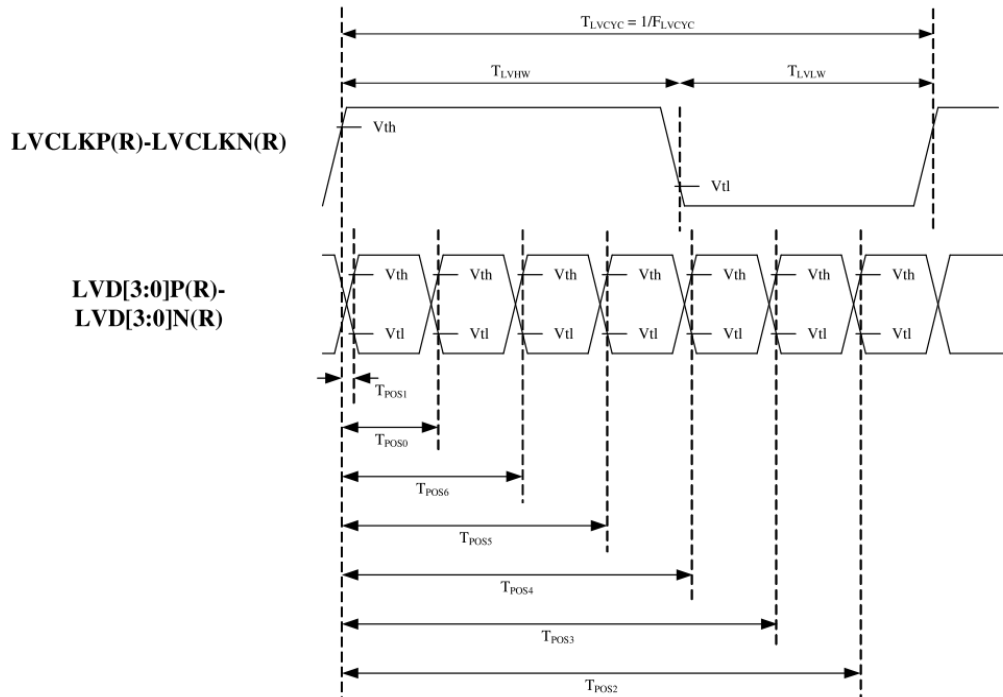

Differential:

LVD[3:0]P-LVD[3:0]N

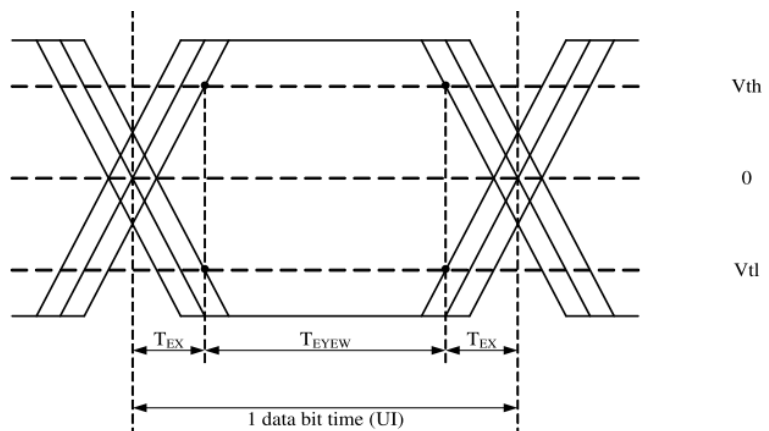

LVDS input eye diagram

3.3.3. DC Electrical Characteristics

Parameter	Symbol	Spec.			Unit	Remark
		Min.	Typ.	Max.		
Differential input high Threshold voltage	Vth	-	-	+0.1	V	Vcm=1.2V
Differential input low Threshold voltage	Vtl	-0.1	-	-	V	
Differential input common Mode voltage	Vcm	1	1.2	1.7- V _{id} /2	V	-
Differential input voltage	V _{id}	0.2	-	0.6	V	-
Differential input leakage Current	Vleak	-10	-	+10	μA	-

Single-ended:
 LVCLKP(R),
 LVCLKN(R),
 LVD[3:0]P(R),
 LVD[3:0]N(R)

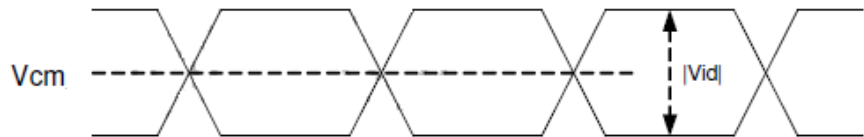

Differential:
 LVCLKP(R)-LVCLKN(R),
 LVD[3:0]P(R)-
 LVD[3:0]N(R)

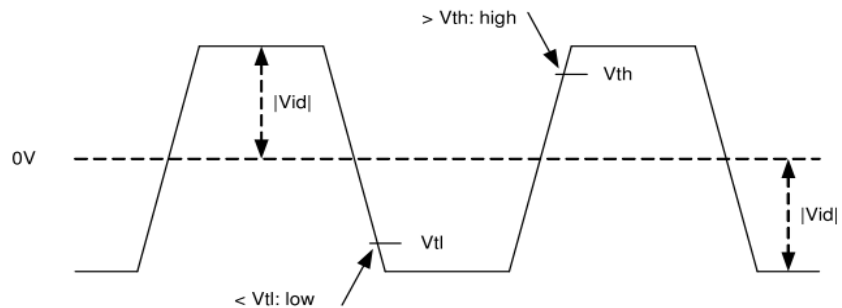

3.3.4. Timing

Parameter	Symbol	1920xRGBx720 (Two Port LVDS)			Unit
		Min.	Typ.	Max.	
CLK frequency	F _{CLK}	-	44.1	-	MHz
Horizontal valid data	t _{hd}	960			DCLK
1 Horizontal Line	t _h	984	992	1005	DCLK
Vertical valid data	t _{vd}	720			H
1 Vertical field	t _v	730	741	753	H
Frame rate	FR	59.4	60	60.6	Hz

Note: DE mode only.

3.3.5. Data Input Format

Panel LVDS format follow standard LVDS format:

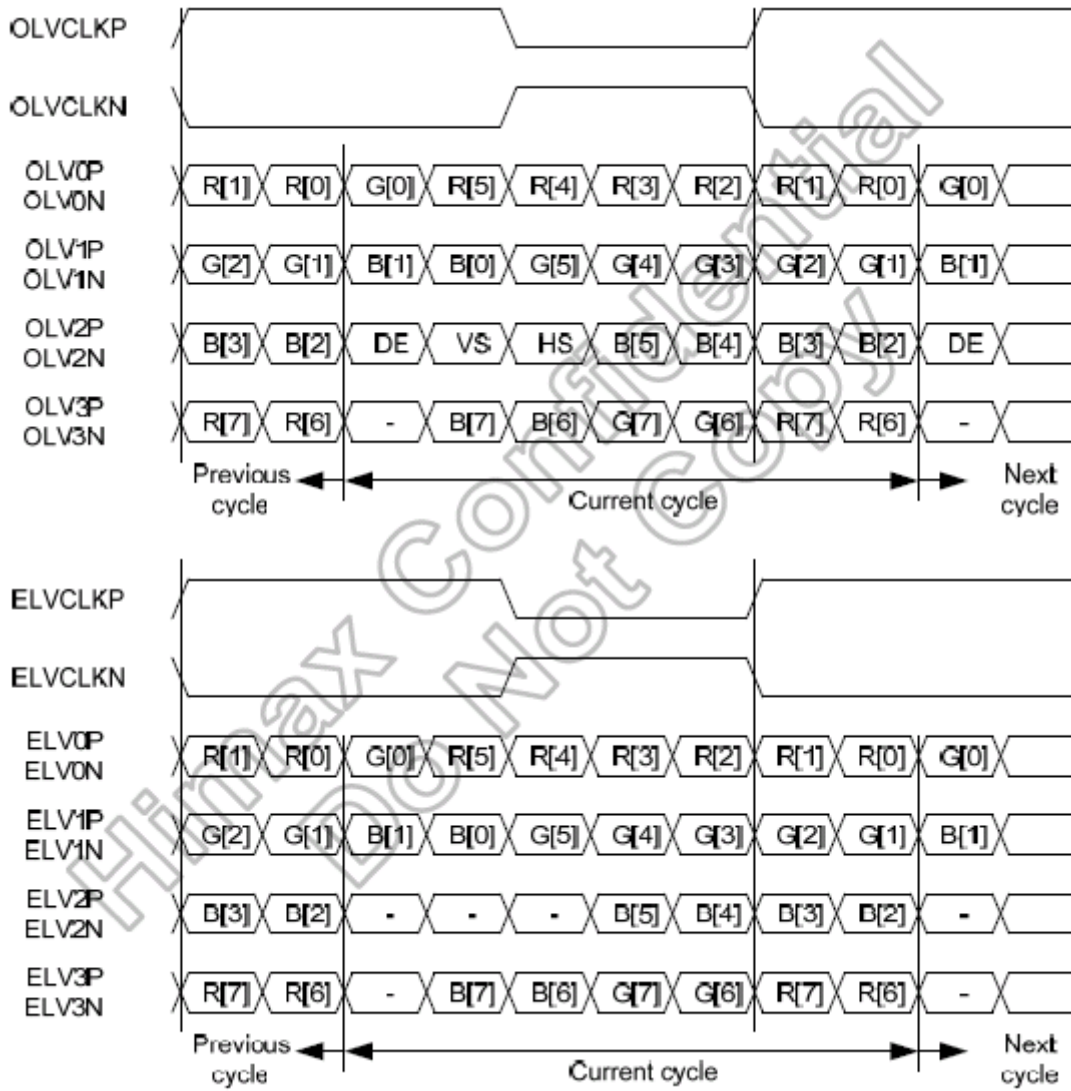

VESA format (8bit)

Notice: Panel LVDS interface Spec, Odd = 1st Pixel, Even = 2nd Pixel

3.3.6. Reset timing

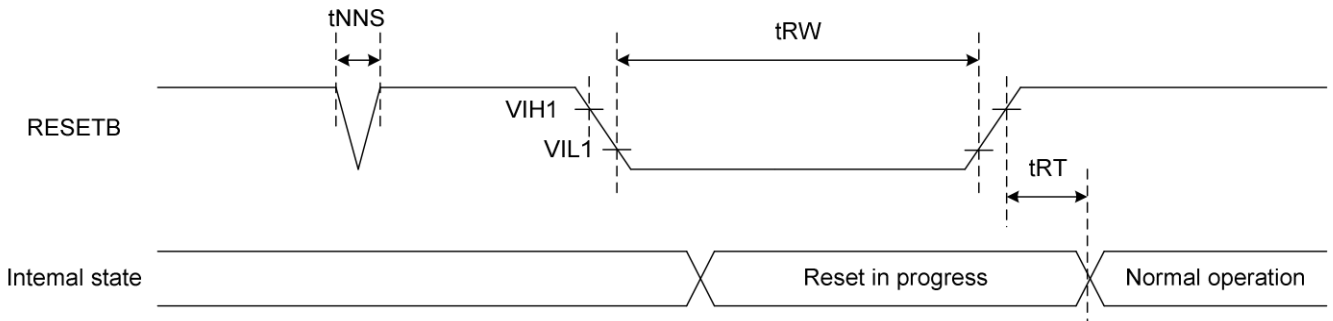

Signal	Parameter	Symbol	Spec.			Unit	Remark
			Min.	Typ.	Max.		
RESETB	Reset pulse width	t_{RW}	10	-	-	μs	-
	Reset complete time	t_{RT}	-	-	5	μs	-
	Negative spike noise width	t_{NNS}	-	-	100	ns	-

4. Optical Specifications

Item	Symbol	Condition	Values			Unit	Remark
			Min.	Typ.	Max.		
Viewing angle (CR ≥ 10)	θ_L	$\Phi=180^\circ$ (9 o'clock)		85	-	degree	Note 1
	θ_R	$\Phi=0^\circ$ (3 o'clock)		85	-		
	θ_T	$\Phi=90^\circ$ (12 o'clock)		85	-		
	θ_B	$\Phi=270^\circ$ (6 o'clock)		85	-		
Response time	T_{ON}	Normal $\theta=\Phi=0^\circ$	-	15	20	msec	Note 2,3
	T_{OFF}		-	10	15	msec	
Contrast ratio	CR		(700)	1000	-	-	Note 2,4
Color chromaticity	W_X		(0.273)	(0.313)	(0.353)	-	Note 2,5,6
	W_Y		(0.289)	(0.329)	(0.369)	-	
	Rx		(0.602)	(0.642)	(0.682)		
	Ry		(0.254)	(0.294)	(0.334)		
	Gx		(0.234)	(0.274)	(0.314)		
	Gy		(0.635)	(0.675)	(0.715)		
	Bx		(0.112)	(0.152)	(0.192)		
	By		(0.028)	(0.068)	(0.108)		
NTSC			80	85	90	%	Note 2
Gamma			1.9	2.2	2.5		Note 2
Luminance	L		(600)	750	-	cd/m ²	Note 2,6
Luminance uniformity	Y_U		75	80	-	%	Note 2,7

Test Conditions:

- $I_L=220\text{mA}$ (Backlight current), the ambient temperature is 25°C .
- The test systems refer to Note 2.

Note 1: Definition of viewing angle range.

The view angel for $\Theta=85^\circ$ is measured by BM-5A.

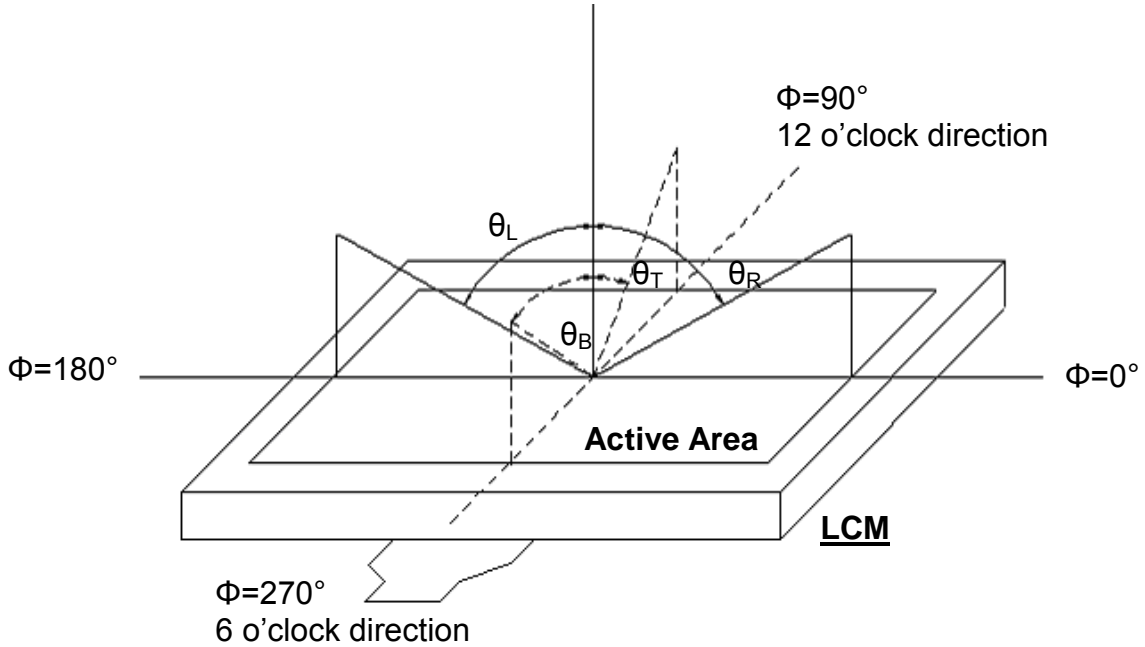

Fig. 4-1 Definition of viewing angle

Note 2: Definition of optical measurement system.

The backlight has been light on for 30 minutes then measured the optical properties at the center point of the LCD screen in dark room. The optical performance are measured by DMS.

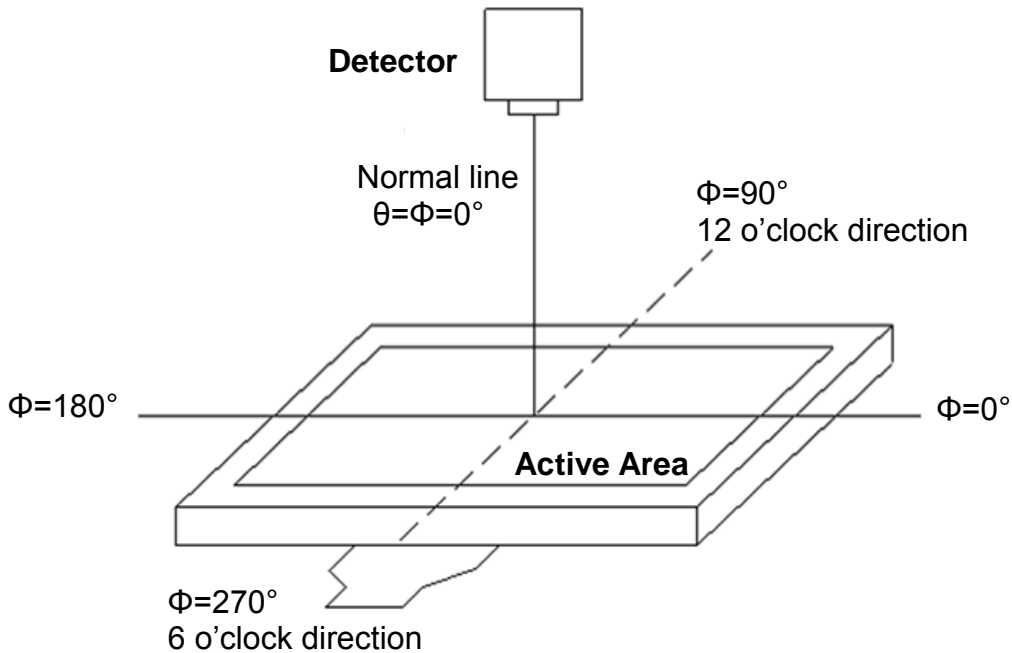

Fig. 4-2 Optical measurement system setup

Note 3: Definition of response time

The response time is defined as the LCD optical switching time interval between “White” state and “Black” state. Rise time (Ton) is the time between photo detector output intensity changed from 10% to 90%, and fall time (Toff) is the time between photo detector output intensity changed from 90% to 10%.

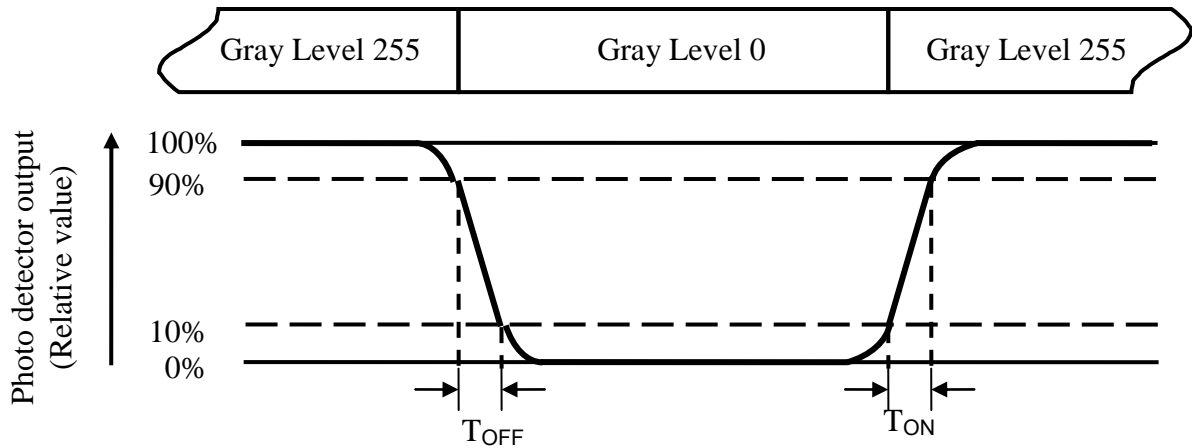

Fig. 4-3 Definition of response time

Note 4: Definition of contrast ratio

$$\text{Contrast ratio (CR)} = \frac{\text{Luminance measured when LCD on the "White" state}}{\text{Luminance measured when LCD on the "Black" state}}$$

Note 5: Definition of color chromaticity (CIE1931)

Color coordinates measured at center point of LCD.

Note 6: All input terminals LCD panel must be ground while measuring the center area of the panel. The LED driving condition is IL=(220mA).

Note 7: Definition of luminance uniformity
Active area is divided into 9 measuring areas.

$$\text{Luminance Uniformity}(Yu) = \frac{B_{min}}{B_{max}}$$

L----- Active area length W----- Active area width

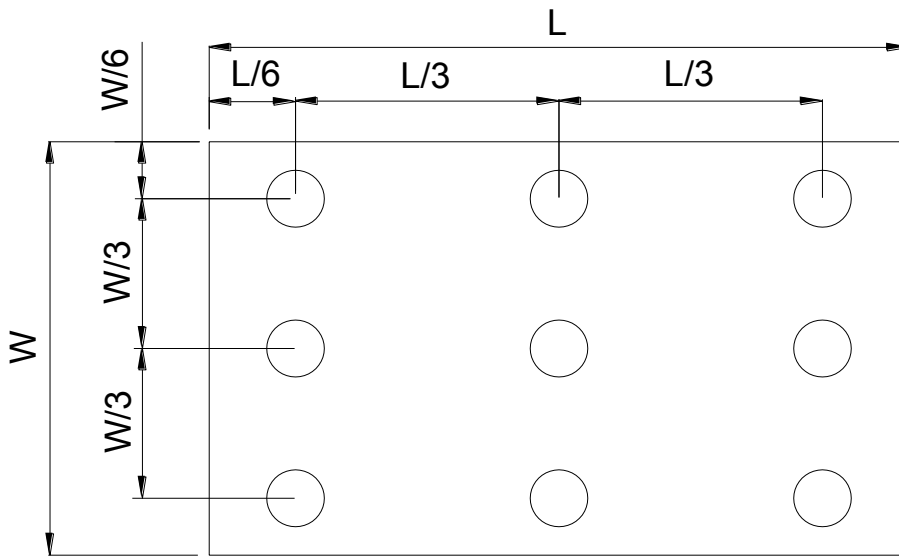

Fig. 4-4 Definition of measuring points

5. Reliability Test Items

Item	Test Conditions	Remark
High Temperature Storage Test	Ta = 90°C, 504 hours	(1) (2) (4) (5)
Low Temperature Storage Test	Ta=-40°C, 504 hours	
High Temperature Operation Test	Ts=85°C, 504 hours	
Low Temperature Operation Test	Ta=-30°C, 504 hours	
High Temperature & High Humidity Operation Test	Ta=60°C, RH 90%, 504 hours	
Thermal Shock	(Ta=-30°C 30min)→(Ts=85°C 30min)]/cycle, 100cycles	
ESD Test (Operation)	Condition 1 : C = 150pF, R = 330_ Contact Discharge, ± 8KV Condition 2 : C = 150pF, R = 330_, Air Discharge, ± 15KV	(5)
Mechanical Shock	100G, 6ms, half sine wave, 3 times for each direction of ±X, ±Y, ±Z	(1)(3)
Mechanical Vibration	Frequency: 10 ~55~10Hz;Sweep Mode: Log Sweep Sweep time: 1Oct/min; Acceleration: 1.5G;Test time:2 hr for each direction of X, Y, Z.	(1)(3)
Packaging Vibration Test	1.47Grms X, Y, Z three axes (30min /axis) [Spectrum : 5Hz(0.015G2/Hz) , 100Hz(0.015G2/Hz) , 200Hz(0.0037G2/Hz)]	
Packaging Drop Test	1corner, 3edges, 6faces (1 time/direction) <follow ISTA(1A) Height> 0kg ≤ W < 10kg : 76cm, 10kg ≤ W < 19kg : 61cm, 19kg ≤ W < 28kg : 46cm, 28kg ≤ W < 45kg : 31cm, 45kg ≤ W ≤ 68kg : 20cm	

Note (1) Ta is ambient temperature, Ts is panel surface temperature.

Note (2) Evaluation should be tested after storage at room temperature for more than two hour.

Note (3) At testing Vibration and Shock, the fixture in holding the module has to be hard and rigid enough so that the module would not be twisted or bent by the fixture.

Note (4) A certain level of Mura (non-uniformity) of dark / black image will happen several days after high temperature testing (H.T.T.). There is a slowly part recovery over a long time (several months).Such a long exposure time like in H.T.T. will normally not happen in a real application. Therefore the test H.T.T. was introduced to simulate cycles with normal conditions in-between but with the same total exposure time what show a significant reduced Mura.

The root cause is related to tension generated due to different amount of shrinking in the stack of layers in the polarizer sheet.

The effect is more significant on larger displays like this size. An investigation into alternative polarizer material showed that there is no better alternative currently available.

Note (5) Criteria Class B: Some performance degradation allowed. No data loss. Self-recoverable. No hardware failures.

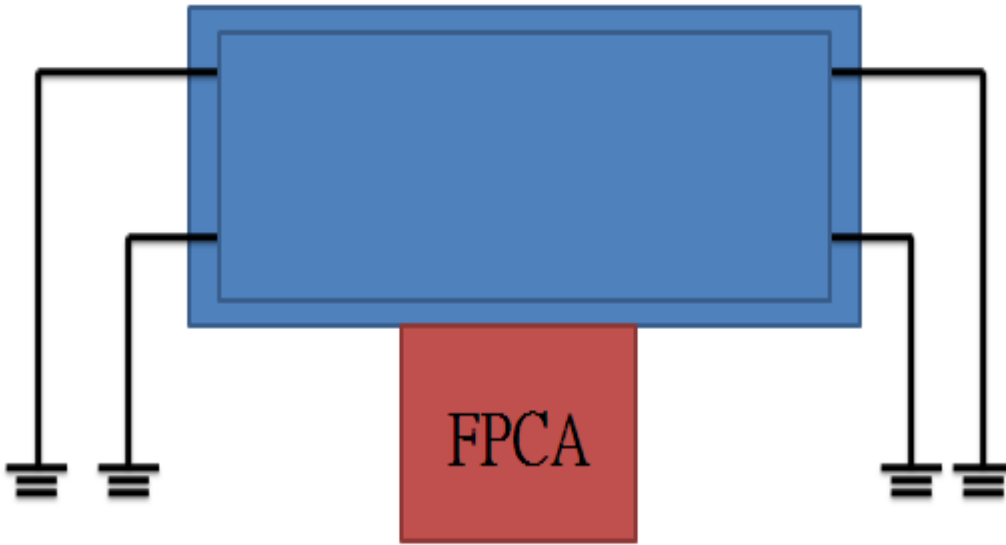

Fig. 5-1 Definition of grounding method

6. General Precautions

6.1. Safety

Liquid crystal is poisonous. Do not put it in your mouth. If liquid crystal touches your skin or clothes, wash it off immediately by using soap and water.

6.2. Handling

1. The LCD panel is plate glass. Do not subject the panel to mechanical shock or to excessive force on its surface.
2. The polarizer attached to the display is easily damaged. Please handle it carefully to avoid scratch or other damages.
3. To avoid contamination on the display surface, do not touch the module surface with bare hands.
4. Keep a space so that the LCD panels do not touch other components.
5. Put cover board such as acrylic board on the surface of LCD panel to protect panel from damages.
6. Transparent electrodes may be disconnected if you use the LCD panel under environmental conditions where the condensation of dew occurs.
7. Do not leave module in direct sunlight to avoid malfunction of the ICs.

6.3. Static Electricity

1. Be sure to ground module before turning on power or operating module.
2. Do not apply voltage which exceeds the absolute maximum rating value.

6.4. Storage

1. Store the module in a dark room where must keep at $25\pm 10^{\circ}\text{C}$ and 65%RH or less.
2. Do not store the module in surroundings containing organic solvent or corrosive gas.
3. Store the module in an anti-electrostatic container or bag.

6.5. Cleaning

1. Do not wipe the polarizer with dry cloth. It might cause scratch.
2. Only use a soft sloth with IPA to wipe the polarizer, other chemicals might permanent damage to the polarizer.

7. Mechanical Drawing

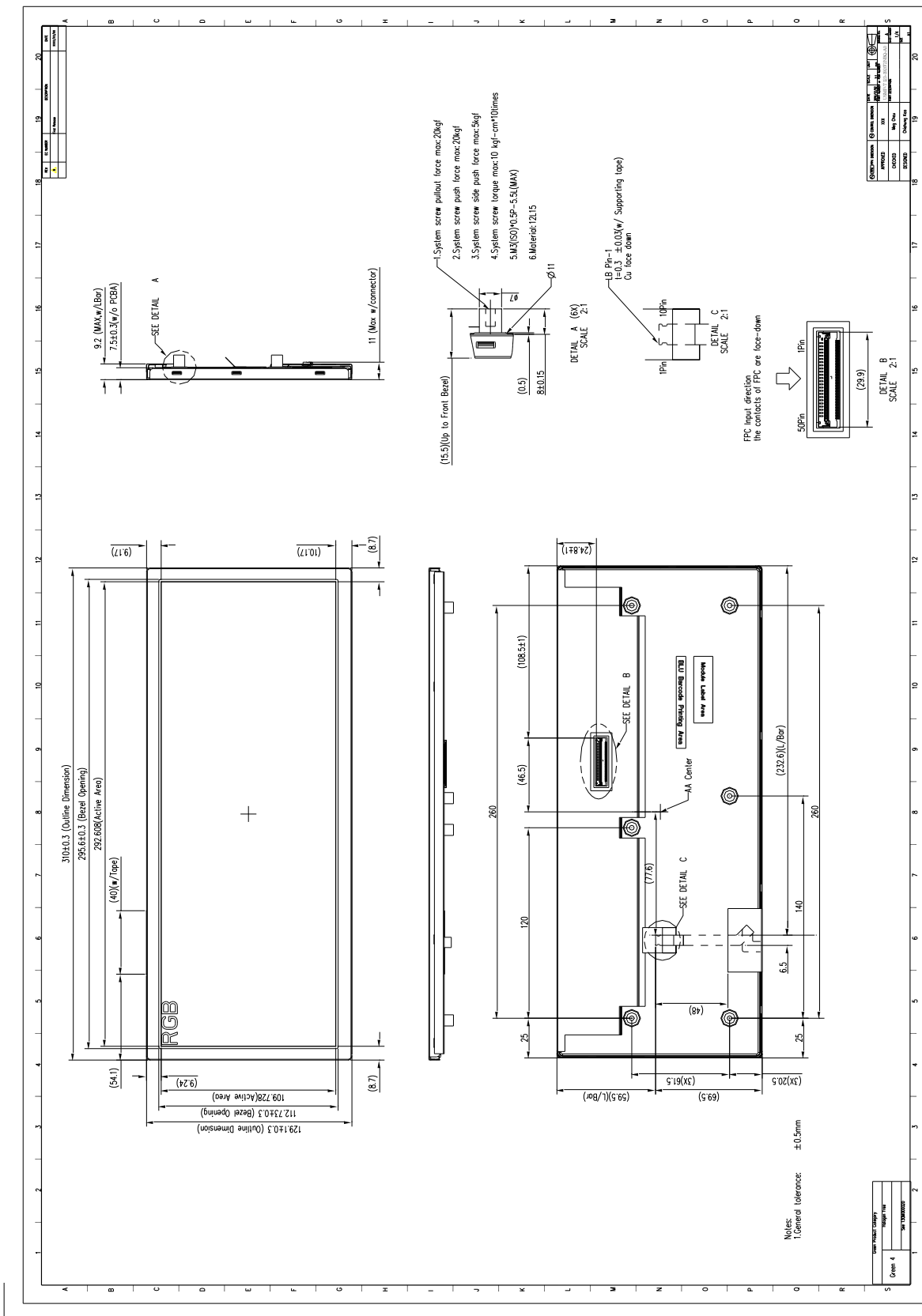

8. Packing Drawing

8.1 Packaging Material Table

No.	Item	Model (Material)	Dimensions(mm)	Unit Weight (kg)	Quantity	Remark
1	LCM Module	Model Name	310(W) X 129(H) X 7.5(D) mm	0.53	20	
2	EPO Box	EPO	542 x 382 x 182mm	0.61	1	
3	A/S Bag	PE	340 x 183 x 0.04mm	0.006	20	
4	Carton	Corrugated Paper	566 x 406 x 216mm	1.014	1	
5	Total Weight	12.34 kg				

8.2 Packaging Quantity

Total LCM quantity in Carton: 20pcs

8.3 Packaging Drawing

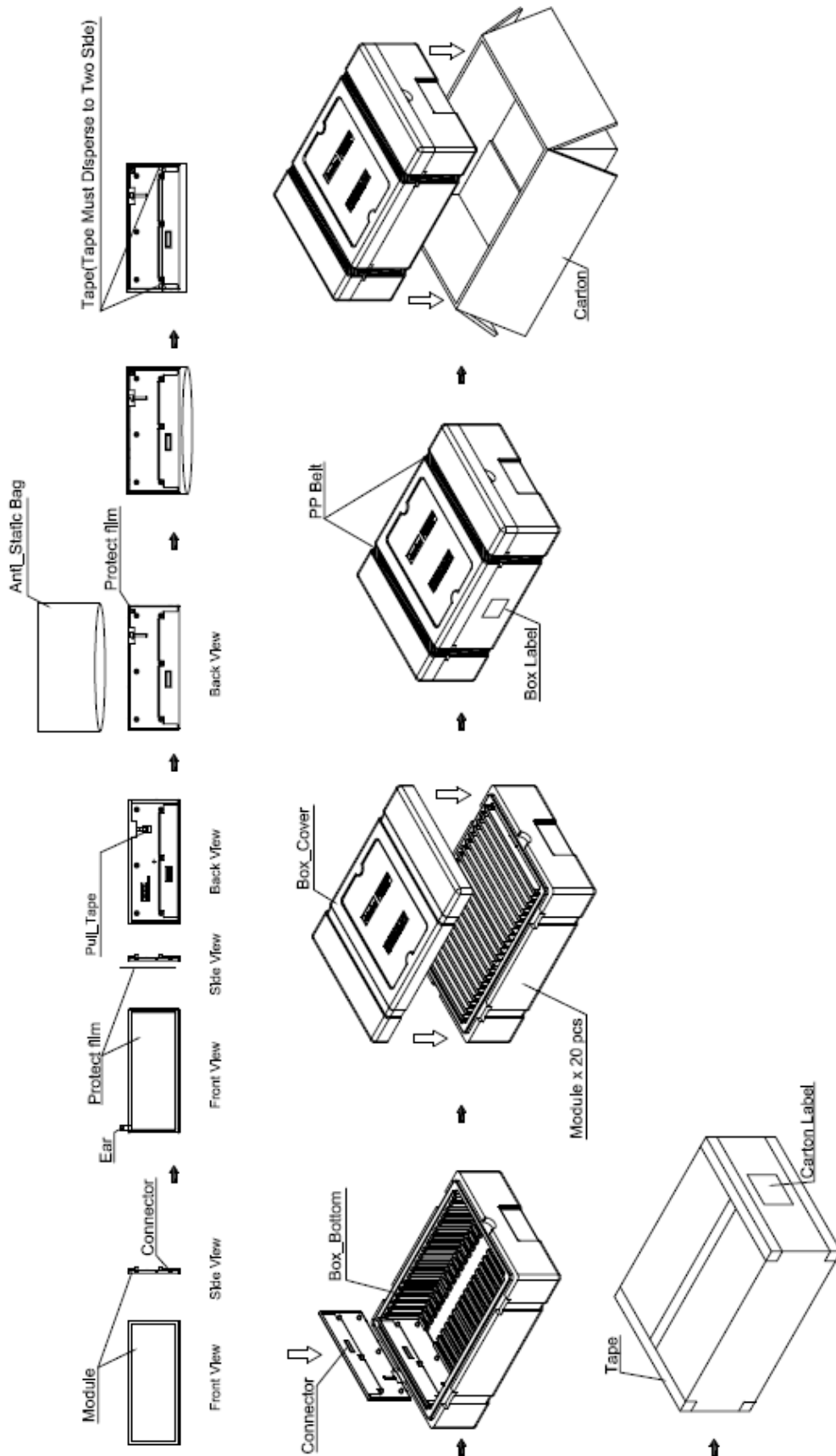

8.4 Shipping Drawing

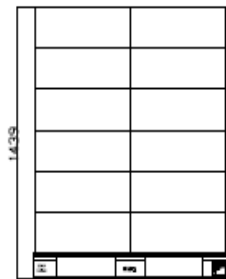
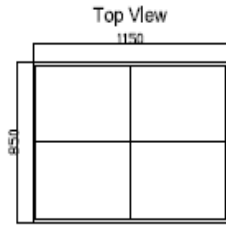

Front View
(Air trans)

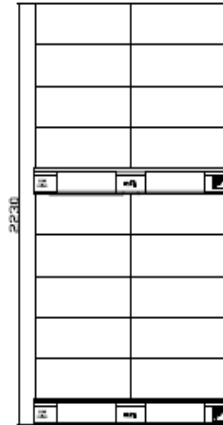

Front View
(Sea trans for normal cont)

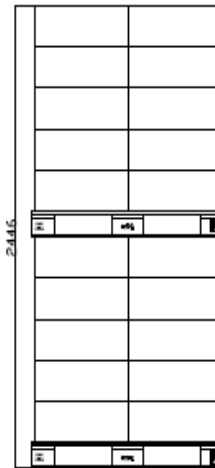

Front View
(Sea trans for HQ)

