

# TFT SPECIFICATION

Part Number	USMP-T070-080048CCJ-A0
Size	7"
Resolution	800 x 480
Brightness	850 cd/m <sup>2</sup>
Contrast	400:1
Viewing Angle	65/65/70/70
Operating Temp.	-20 ~ 70°C

FOR ADDITIONAL INFORMATION  
PLEASE CONTACT:  
[engineering@usmicroproducts.com](mailto:engineering@usmicroproducts.com)

Issue Date	Approved by (customer use)	Checked by	Prepared by

PROPRIETARY NOTE: THIS SPECIFICATION IS THE PROPERTY OF US MICRO PRODUCTS AND SHALL NOT BE REPRODUCED OR COPIED WITHOUT THE WRITTEN PERMISSION OF US MICRO PRODUCTS AND MUST BE RETURNED TO US MICRO PRODUCTS UPON ITS REQUEST.

**(800) 741-7755**  
[www.usmicroproducts.com](http://www.usmicroproducts.com)

## RECORD OF REVISION

Revision Date	Page	Contents	Editor
2014/2/27	--	New Release	Tony
2014/8/8		Change Cover Lens supplier	Kokai
2017/2/23		Model name change from USMP-VC070WV03L-TP to USMP-T070-080048CCJ-A0	David
2017/2/23		TP sensor change to full overcoat	David

## 1. INTRODUCTION

USMP-T070-080048CCJ-A0 is a color active matrix TFT-LCD that uses amorphous silicon TFT as a switching device. This model is composed of a TFT-LCD panel, LCD driving circuit, LED back-light and [Projective Capacitive touch panel](#). This TFT-LCD has a high resolution (800(R.G.B) X 480) and can display up to 262,144 colors.

### 1-1. Features

- 7" WVGA (16:9 diagonal) configuration
- LED Back-light is with CABLE connection
- Interface: 6-bits LVDS interface
- [Capacitive Touch Panel with USB Interface.](#)
- [LED Driver \(VLED = 12V\)](#)

### 1-2. Applications

- Portable TV
- Car user DVD
- Industrial application
- HMI (Human machine interface)

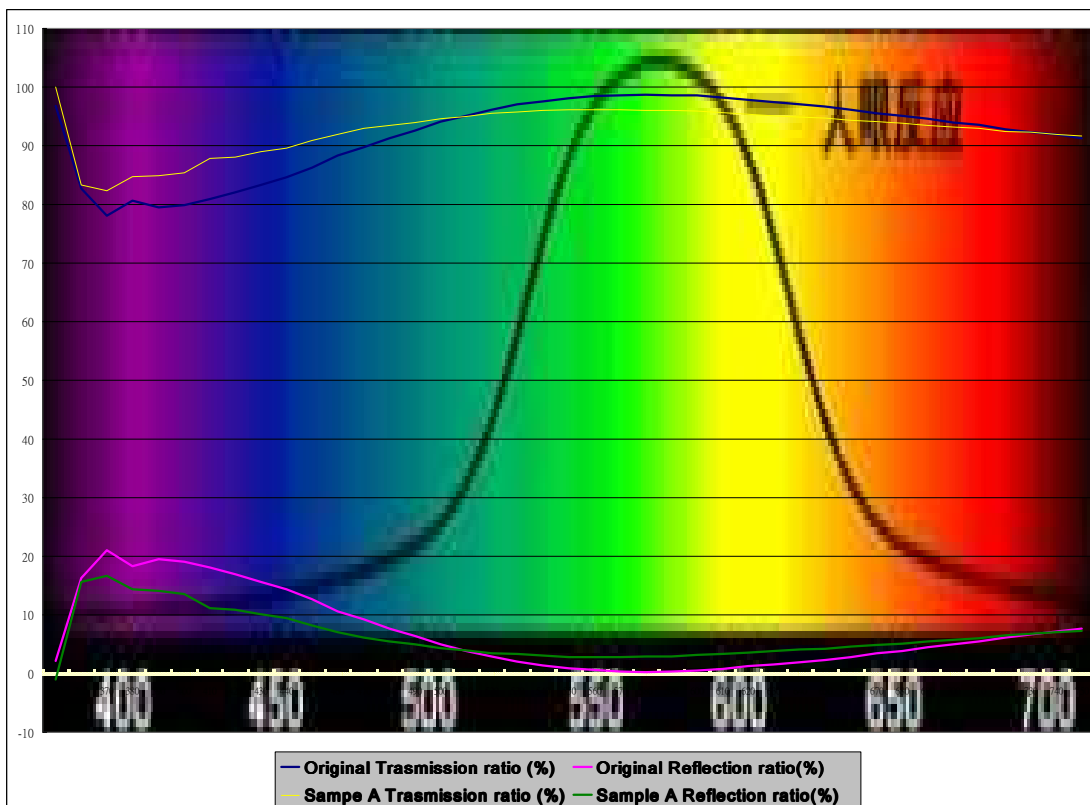

## 2. PHYSICAL SPECIFICATIONS

Item	Specifications	unit
Display resolution(dot)	800RGB (W) x 480(H)	dots
Active area	152.4 (W) x 91.44 (H)	mm
Pixel pitch	0.1905 (W) x 0.1905 (H)	mm
Color configuration	R.G.B Vertical stripe	
Overall dimension	165.0(W) x 106.0(H) x 9.31(T)	mm
Brightness	850	cd/m <sup>2</sup>
Contrast ratio	400 : 1	
Backlight unit	LED	
Display color	262,144	colors

### 3. ABSOLUTE MAX. RATINGS

#### 3-1 Electrical Absolute Rating

##### 3-1-1 TFT LCD Module

Item	Symbol	Values		UNIT	Note
		Min.	Max.		
Power voltage	VCC	-0.5	4.0	V	GND=0V
Voltage range at any terminal		-0.5	VCC+0.3	V	

#### 3-2 Environment Absolute Rating

Item	Symbol	Min.	Max.	Unit	Note
Operating Temperature	Topa	-20	70	°C	
Storage Temperature	Tstg	-30	80	°C	

## 4. ELECTRICAL CHARACTERISTICS

### 4-1 TFT LCD Module voltage

		MIN	NOM	MAX	UNIT
$V_{CC}$	Supply voltage	3	3.3	3.6	V
$V_{IH}$	High-level input voltage (SHTDN)	2			V
$V_{IL}$	Low-level input voltage (SHTDN)			0.8	V
$ V_{ID} $	Magnitude differential input voltage	0.1		0.6	V
$V_{IC}$	Common-mode input voltage	$\frac{ V_{ID} }{2}$		$2.4 - \frac{ V_{ID} }{2}$	V

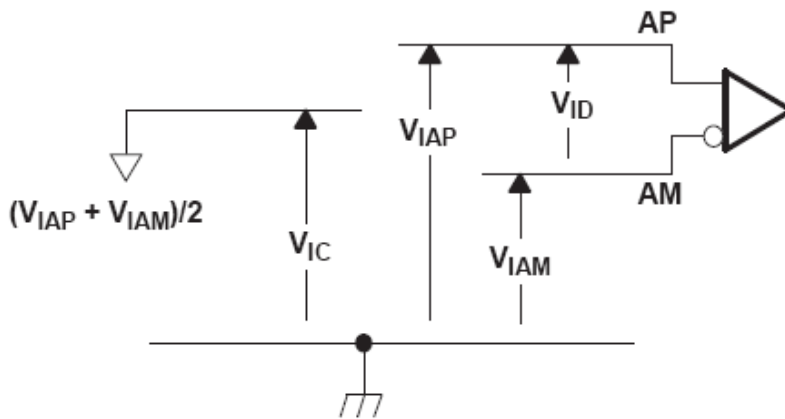

ITEM	SYMBOL	MIN	TYP	MAX	UNIT	CONDITION
Power Supply Voltage For LCD	$V_{CC}$	3.0	3.3	3.6	V	
Power Supply Current For LCD	$I_{CC}$	-	180	230	mA	Black pattern
Power Supply Voltage For LED	$V_{LED}$	-	12	14	V	
ADJ signal frequency	$f_{PWM}$	5	--	100	kHz	
ADJ signal logic level High	$V_{IH}$	-	3.3	5.0	V	
ADJ signal logic level Low	$V_{IL}$	-	-	0.5	V	

### 4-2 LED Driving Conditions

ITEM	SYMBOL	MIN	TYP	MAX	UNIT	CONDITION
LED Backlight Voltage	$V_{BL}$	15.0	16.5	18.0	V	For reference
LED Backlight Current	$I_{BL}$	-	240	-	mA	$T_a=25^{\circ}\text{C}$
LED Life Time			50K		Hr	Note*

Note\* : Brightness to be decreased to 50% of the initial value.

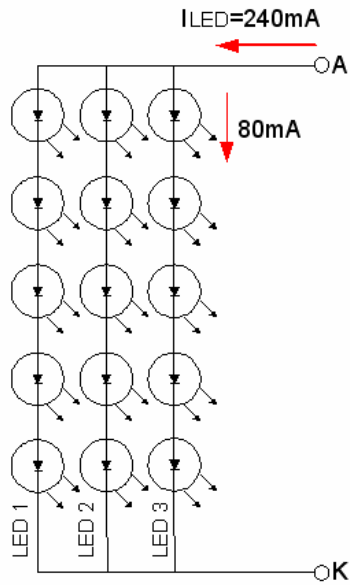

The constant current source is needed for white LED back-light driving.

When LCM is operated over 60°C ambient temperature, the  $I_{BL}$  of the LED back-light should be adjusted to 200mA max

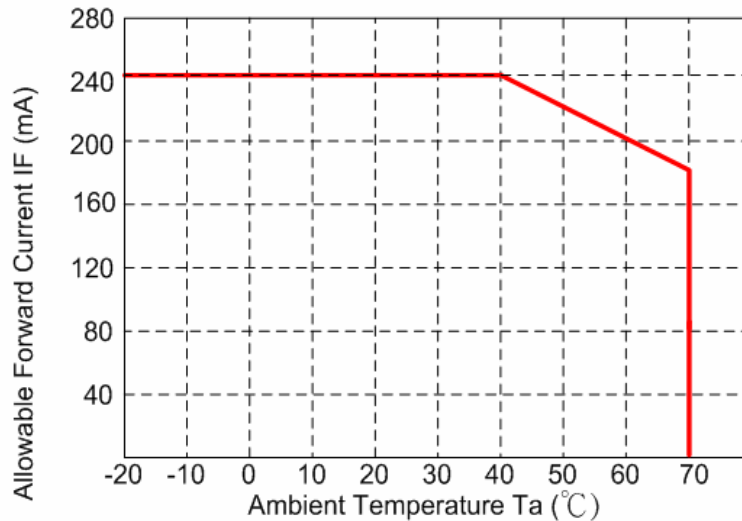

### 4-3 Touch Panel Basic Characteristic

ITEM	SPECIFICATION
<b>Type</b>	Projective Capacitive Touch Panel
<b>Activation</b>	Two-fingers or Signal-finger
<b>X/Y Position Reporting</b>	Absolute Position
<b>Touch Force</b>	No contact pressure required
<b>Calibration</b>	No need for calibration
<b>Report Rate</b>	Approx 25 points/sec

### Interface

CN6		
Pin No.	Symbol	Function
1	DGND	USB POWER GND
2	DA-	USB Data-
3	DA+	USB Data+
4	VDD	USB POWER 5V
5	NC	Non Use
6	NC	Non Use



## 5. INTERFACE

Pin No.	Symbol	Function
1	VDD	POWER SUPPLY:3.3V
2	VDD	POWER SUPPLY:3.3V
3	GND	Power Ground
4	GND	Power Ground
5	IN0-	Transmission Data of Pixels
6	IN0+	Transmission Data of Pixels
7	GND	Power Ground
8	IN1-	Transmission Data of Pixels 1
9	IN1+	Transmission Data of Pixels 1
10	GND	Power Ground
11	IN2-	Transmission Data of Pixels 2
12	IN2+	Transmission Data of Pixels 2
13	GND	Power Ground
14	CLK-	Sampling Clock
15	CLK+	Sampling Clock
16	GND	Power Ground
17	VLED	POWER SUPPLY for Backlight, 12V
18	VLED	POWER SUPPLY for Backlight, 12V
19	GND	Power Ground
20	LEDADJ	LED PWM SIGNAL 3.3V

## 6. OPTICAL CHARACTERISTICS

Item	Symbol	Condition	Min.	Typ.	Max.	Unit	Note
Viewing Angle	Front	$\theta f$	60	65	--	deg.	(1)(2)(3)
	Back	$\theta b$	60	65	--		
	Left	$\theta l$	65	70	--		
	Right	$\theta r$	65	70	--		
Contrast ratio	CR	$\Theta=\Phi=0^\circ$	--	400	--	--	(1)(3)
Response Time	$T_r$	$\Theta=\Phi=0^\circ$	--	5	10	ms	(1)(4)
	$T_f$		--	11	16	ms	(1)(4)
Color chromaticity	White	$W_x$	0.239	0.299	0.359	--	(1)
		$W_y$	0.268	0.328	0.388		
Luminance	L	$\Theta=\Phi=0^\circ$	650	850	--	cd/m <sup>2</sup>	(1)(5)
Luminance Uniformity	$\Delta L$	$\Theta=\Phi=0^\circ$	70	--	--	%	(1)(5)(6)

Note 1: Ta=25°C. To be measured on the center area of panel after 10 minutes operation.

Note 2: Definition of Viewing Angle

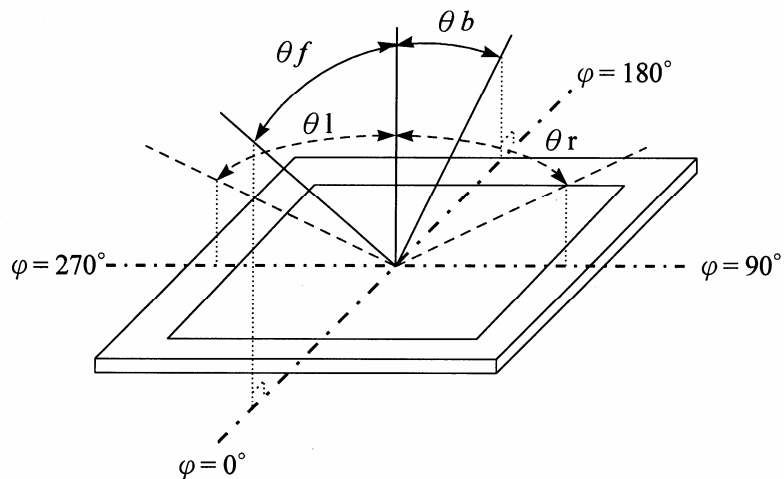

Note 3: Definition of contrast ratio:

Contrast ratio is calculated with the following formula.

$$\text{Contrast ratio (CR)} = \frac{\text{Photo detector output when LCD is at "White" state}}{\text{Photo detector Output when LCD is at "Black" state}}$$

Note 4: Definition of response time:

The output signals of photo detector are measured when the input signals are changed from "black" to "white"(falling time) and from "white" to "black" (rising time) respectively. The response time is defined as the time interval between the 10% and 90% of amplitudes. Refer to figure as below.

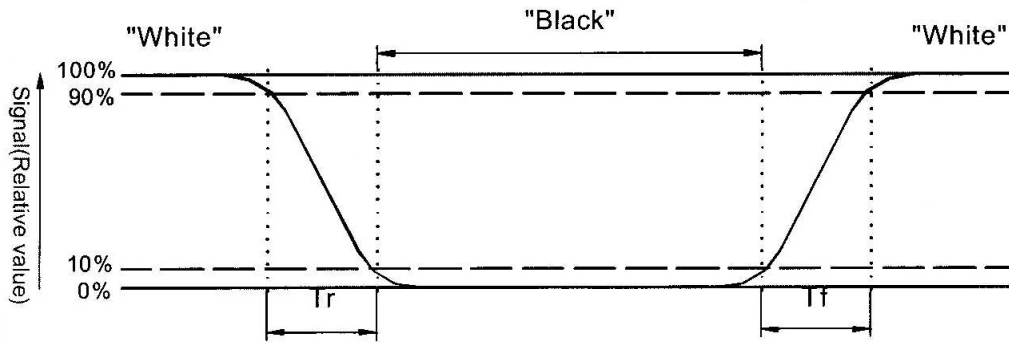

Note 5 : Luminance is measured at point 5 of the display.

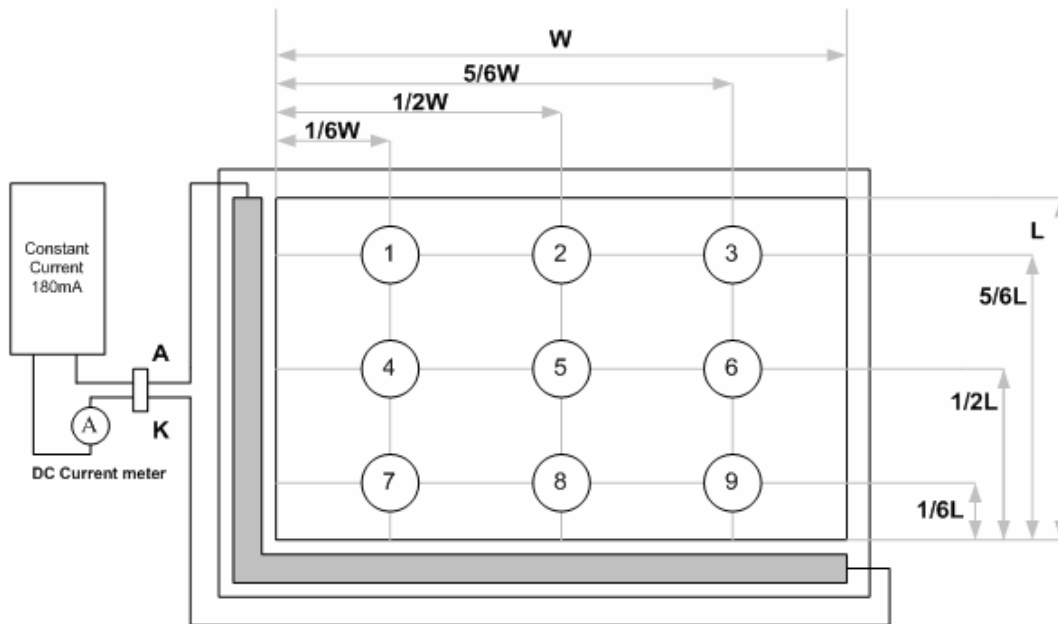

Note 6 : Definition of Luminance Uniformity

$$\Delta L = [ L(\text{min.}) \text{ of } 9 \text{ points} / L(\text{max.}) \text{ of } 9 \text{ points}] \times 100\%$$

## 7. INPUT SIGNAL (DE ONLY MODE)

### 7-1 LVDS Singal

switching characteristics over recommended operating conditions (unless otherwise noted)

PARAMETER	TEST CONDITIONS	MIN	TYP†	MAX	UNIT
$t_{su}$ Setup time, D0–D20 to CLKOUT↓	$C_L = 8 \text{ pF}$ , See Figure 5	5			ns
$t_h$ Data hold time, CLKOUT↓ to D0–D20		5			ns
$t_{(RSKM)}$ Receiver input skew margin§ (see Figure 7)	$t_c = 15.38 \text{ ns } (\pm 0.2\%)$ , $ \text{Input clock jitter}  < 50 \text{ ps}^{\dagger\dagger}$	550	700		ps
$t_d$ Delay time, CLKIN↑ to CLKOUT↓ (see Figure 7)	$V_{CC} = 3.3 \text{ V}$ , $t_c = 15.38 \text{ ns } (\pm 0.2\%)$ , $T_A = 25^\circ\text{C}$	3	5	7	ns
$t_{en}$ Enable time, $\overline{\text{SHTDN}}$ to phase lock	See Figure 7		1		ms
$t_{dis}$ Disable time, $\overline{\text{SHTDN}}$ to off state	See Figure 8		400		ns
$t_t$ Transition time, output (10% to 90% $t_r$ or $t_f$ ) (data only)	$C_L = 8 \text{ pF}$		3		ns
$t_t$ Transition time, output (10% to 90% $t_r$ or $t_f$ ) (clock only)	$C_L = 8 \text{ pF}$		1.5		ns
$t_w$ Pulse duration, output clock			$0.50 t_c$		ns

† All typical values are at  $V_{CC} = 3.3 \text{ V}$ ,  $T_A = 25^\circ\text{C}$ .

§ The parameter  $t_{(RSKM)}$  is the timing margin available to allocate to the transmitter and interconnection skews and clock jitter. The value of this parameter at clock periods other than 15.38 ns can be calculated from  $t_{(RSKM)} = t_c/14 - 550 \text{ ps}$ .

††  $|\text{Input clock jitter}|$  is the magnitude of the change in input clock period.

#### PARAMETER MEASUREMENT INFORMATION

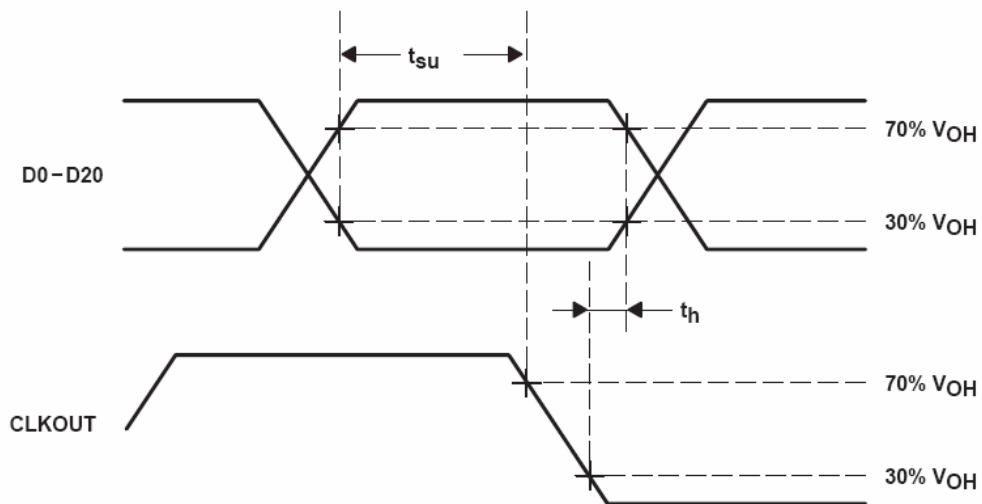

Figure 5. Setup and Hold Time Waveforms

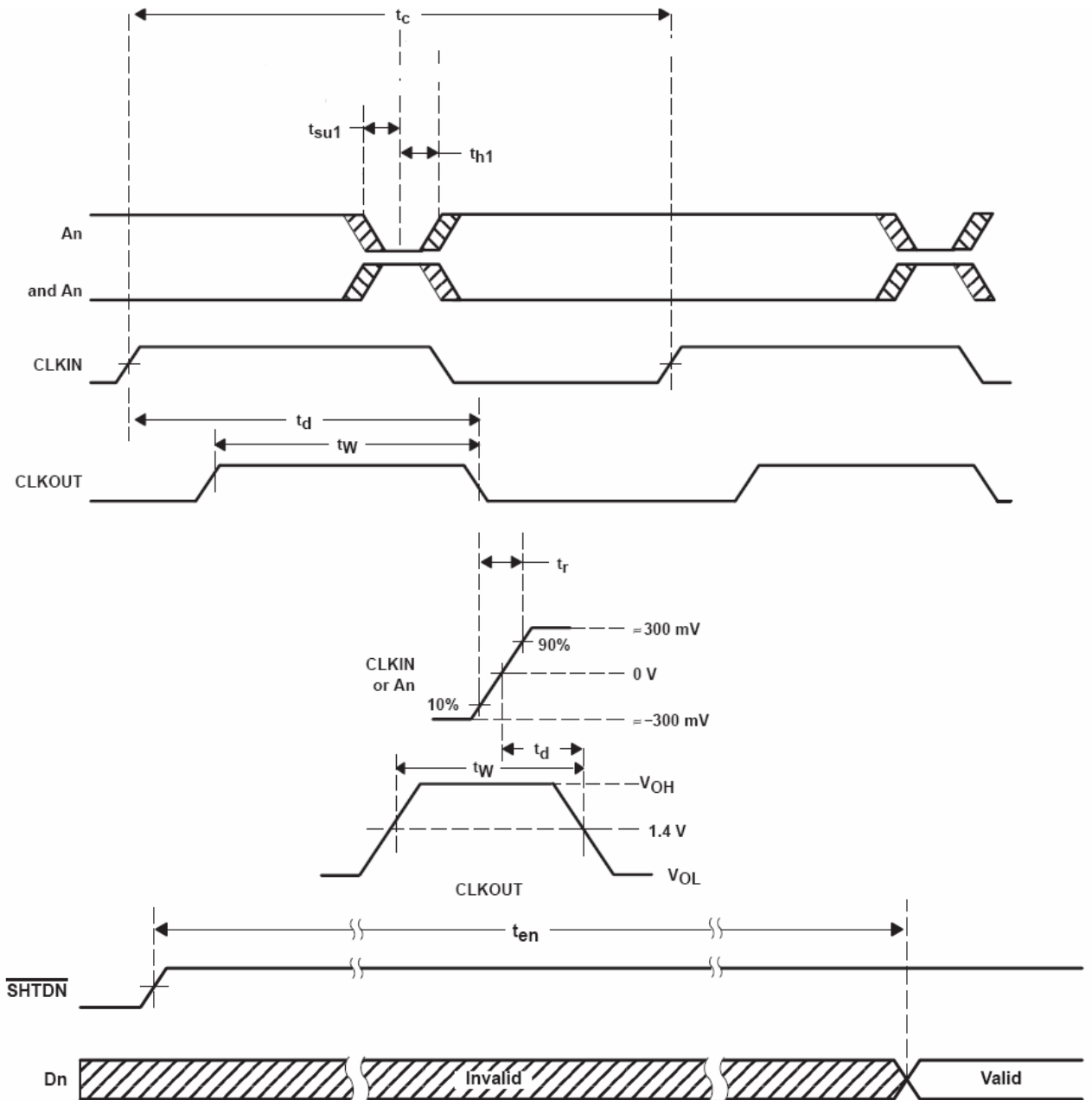

Figure 7. Enable Time Waveforms

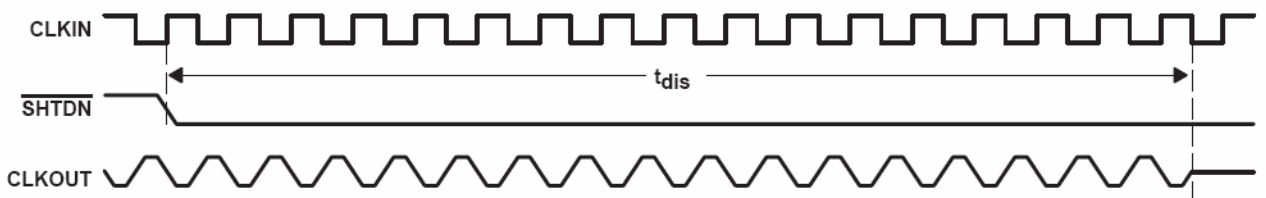
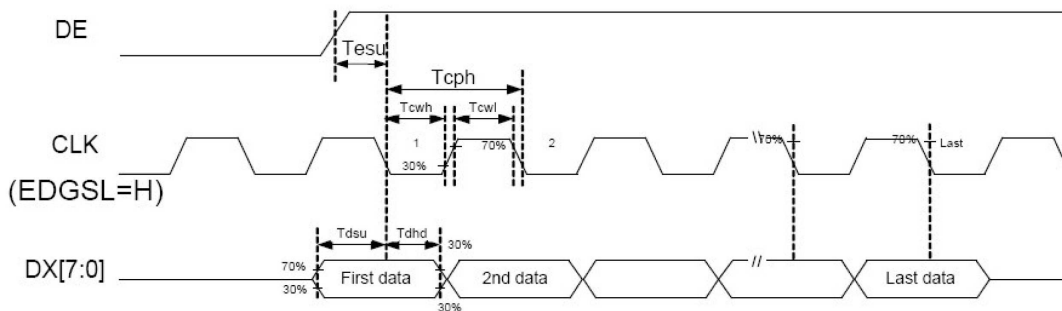
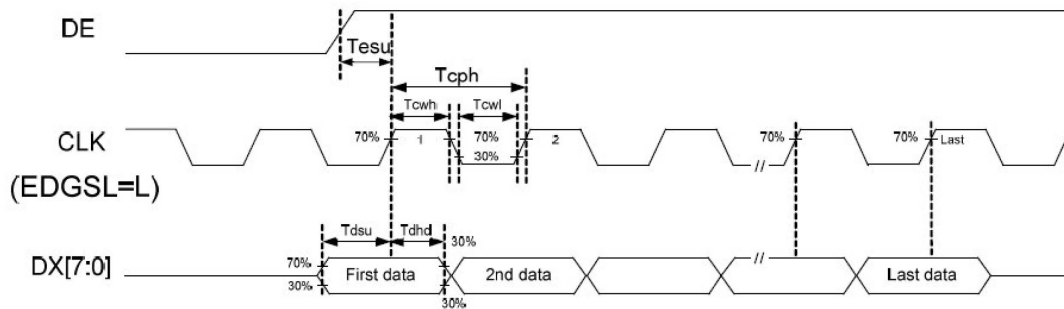

Figure 8. Disable Time Waveforms

### 7-2 TTL Signal (DE Only mode)

Parameter	Symbol				Unit
		Min.	Typ.	Max.	
Data setup time	Tdsu	6	-	-	ns
Data hold time	Tdhd	6	-	-	Tcph
DE setup time	Tesu	6	-	-	Tcph
CLK frequency	F <sub>CPH</sub>		33.26		MHz
CLK period	T <sub>CPH</sub>		30.06		ns
CLK pulse duty	T <sub>CWH</sub>	40	50	60	%
DE period	T <sub>DEH</sub> +T <sub>DEL</sub>	1000	1056	1200	T <sub>CPH</sub>
DE pulse width	T <sub>DEH</sub>	-	800	-	T <sub>CPH</sub>
DE frame blanking	T <sub>DEB</sub>	10	45	110	T <sub>DEH</sub> +T <sub>DEL</sub>
DE frame width	T <sub>DE</sub>	-	480	-	T <sub>DEH</sub> +T <sub>DEL</sub>

Note : We suggest using the typical value, so it can have better performance.



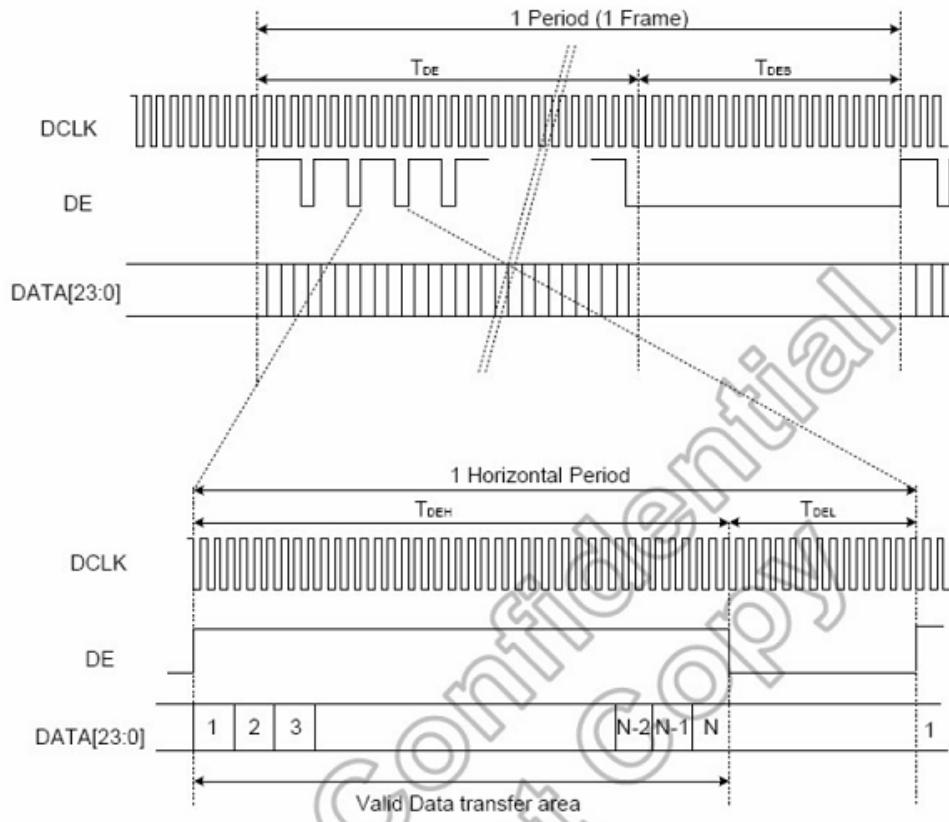

## 8. Touch Panel ELECTRICAL SPECIFICATION

### 8-1. Basic Characteristic

ITEM	SPECIFICATION
Interface Type	Projective Capacitive Multi-Touch Panel
Activation	Two-fingers or Signal-finger

### 8-2. Operation Environmental Characteristic

ITEM	SPECIFICATION
Operation Temperature	-20~70°C
Storage Temperature	-30~80°C

### 8-3. Optical Characteristic

ITEM	SPECIFICATION
Transmittance	80% (Typ)

#### 【Notes】

(1) UV-V is 400nm~700nm Spectrum Transmittance (Reference: Air)

(2) Definition of Transmittance

T(%)=White Luminance Touch on LCM/LCM White Luminance



## 9. RELIABILITY TEST

Test Item	Test Conditions	Note
High Temperature Operation	70±3°C , t=240 hrs	
Low Temperature Operation	-20±3°C , t=240 hrs	
High Temperature Storage	80±3°C , t=240 hrs	1,2
Low Temperature Storage	-30±3°C , t=240 hrs	1,2
Storage at High Temperature and Humidity	60°C, 90% RH , 240 hrs	1,2
Thermal Shock Test	-20°C (30min) ~ 70°C (30min) 100 cycles	1,2
Vibration Test (Packing)	Sweep frequency : 10 ~ 55 ~ 10 Hz/1min Amplitude : 0.75mm Test direction : X.Y.Z/3 axis Duration : 30min/each axis	2

Note 1 : Condensation of water is not permitted on the module.

Note 2 : The module should be inspected after 1 hour storage in normal conditions (15-35°C , 45-65%RH).

## 10 USE PRECAUTIONS

### 10.1 Handling precautions

- (1) The polarizing plate may break easily so be careful when handling it. Do not touch, press or rub it with a hard-material tool like tweezers.
- (2) Do not touch the polarizing plate surface with bare hands so as not to make it dirty. If the surface or other related part of the polarizing plate is dirty, soak a soft cotton cloth or chamois leather in benzine and wipe off with it. Do not use chemical liquids such as acetone, toluene and isopropyl alcohol. Failure to do so may bring chemical reaction phenomena and deteriorations.
- (3) Remove any spit or water immediately. If it is left for hours, the suffered part may deform or decolorize.
- (4) If the LCD element breaks and any LC stuff leaks, do not suck or lick it. Also if LC stuff is stuck on your skin or clothing, wash thoroughly with soap and water immediately.

### 10.2 Installing precautions

- (1) The PCB has many ICs that may be damaged easily by static electricity. To prevent breaking by static electricity from the human body and clothing, earth the human body properly using the high resistance and discharge static electricity during the operation. In this case, however, the resistance value should be approx.  $1M\Omega$  and the resistance should be placed near the human body rather than the ground surface. When the indoor space is dry, static electricity may occur easily so be careful. We recommend the indoor space should be kept with humidity of 60% or more. When a soldering iron or other similar tool is used for assembly, be sure to earth it.
- (2) When installing the module and ICs, do not bend or twist them. Failure to do so may crack LC element and cause circuit failure.
- (3) To protect LC element, especially polarizing plate, use a transparent protective plate (e.g., acrylic plate, glass etc) for the product case.
- (4) Do not use an adhesive like a both-side adhesive tape to make LCD surface (polarizing plate) and product case stick together. Failure to do so may cause the polarizing plate to peel off

### 10.3 Storage precautions

- (1) Avoid a high temperature and humidity area. Keep the temperature between  $0^{\circ}\text{C}$  and  $35^{\circ}\text{C}$  and also the humidity under 60%.
- (2) Choose the dark spaces where the product is not exposed to direct sunlight or fluorescent light.
- (3) Store the products as they are put in the boxes provided from us or in the same conditions as we recommend.

## 10.4 Operating precautions

- (1) Do not boost the applied drive voltage abnormally. Failure to do so may break ICs. When applying power voltage, check the electrical features beforehand and be careful. Always turn off the power to the LC module controller before removing or inserting the LC module input connector. If the input connector is removed or inserted while the power is turned on, the LC module internal circuit may break.
- (2) The display response may be late if the operating temperature is under the normal standard, and the display may be out of order if it is above the normal standard. But this is not a failure; this will be restored if it is within the normal standard.
- (3) The LCD contrast varies depending on the visual angle, ambient temperature, power voltage etc. Obtain the optimum contrast by adjusting the LC drive voltage.
- (4) When carrying out the test, do not take the module out of the low-temperature space suddenly. Failure to do so will cause the module condensing, leading to malfunctions.
- (5) Make certain that each signal noise level is within the standard (L level: 0.2V<sub>dd</sub> or less and H level: 0.8V<sub>dd</sub> or more) even if the module has functioned properly. If it is beyond the standard, the module may often malfunction. In addition, always connect the module when making noise level measurements.
- (6) The CMOS ICs are incorporated in the module and the pull-up and pull-down function is not adopted for the input so avoid putting the input signal open while the power is ON.
- (7) The characteristic of the semiconductor element changes when it is exposed to light emissions, therefore ICs on the LCD may malfunction if they receive light emissions. To prevent these malfunctions, design and assemble ICs so that they are shielded from light emissions.
- (8) Crosstalk occurs because of characteristics of the LCD. In general, crosstalk occurs when the regularized display is maintained. Also, crosstalk is affected by the LC drive voltage. Design the contents of the display, considering crosstalk.

## 10.5 Other

- (1) Do not disassemble or take the LC module into pieces. The LC modules once disassembled or taken into pieces are not the guarantee articles.
- (2) The residual image may exist if the same display pattern is shown for hours. This residual image, however, disappears when another display pattern is shown or the drive is interrupted and left for a while. But this is not a problem on reliability.
- (3) USMP will provide one year warranty for all products and three months warranty for all repairing products.

# 11 OUTLINE DIMENSION

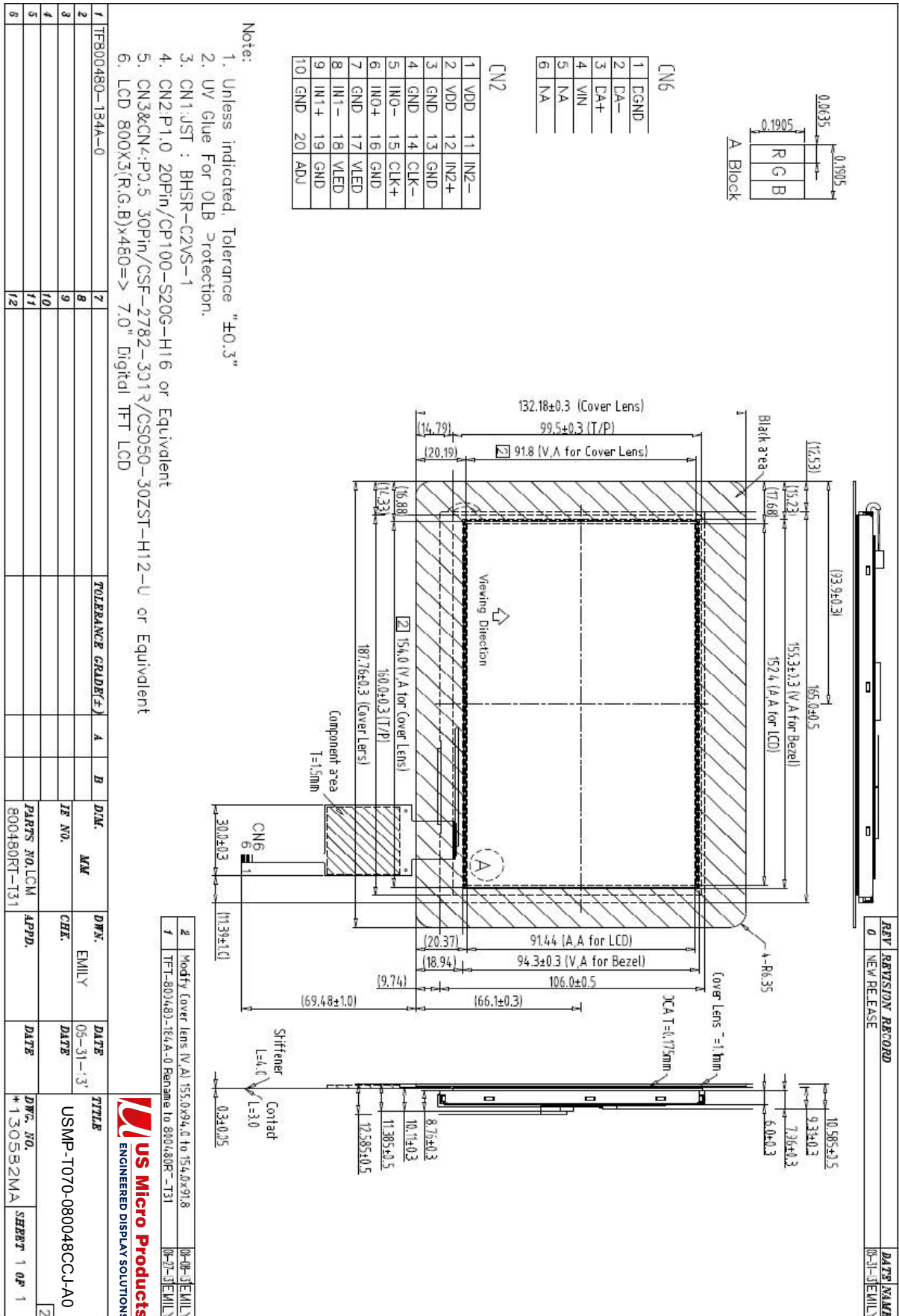

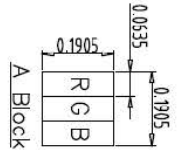

CN6

1	DGND
2	DA-
3	DA+
4	VIN
5	NA
6	NA

CN2

1	VDD	11	IN2-
2	VDD	12	IN2+
3	GND	13	GND
4	GND	14	CLK-
5	INO-	15	CLK+
6	INO+	16	GND
7	GND	17	VLED
8	IN1-	18	VLED
9	IN1+	19	GND
10	GND	20	ADJ

- Note:
1. Unless indicated, Tolerance "±0.3"
  2. UV Glue For OLB Protection.
  3. CN1:JST : BHSR-02YS-1
  4. CN2:P1.0 20Pin/CP100-S20G-H16 or Equivalent
  5. CN3&CN4:P0.5 30Pin/CSF-2782-301R/CS050-30ZST-H12-U or Equivalent
  6. LCD 800X3(R,G,B)x480=> 7.0" Digital TFT LCD

Back View

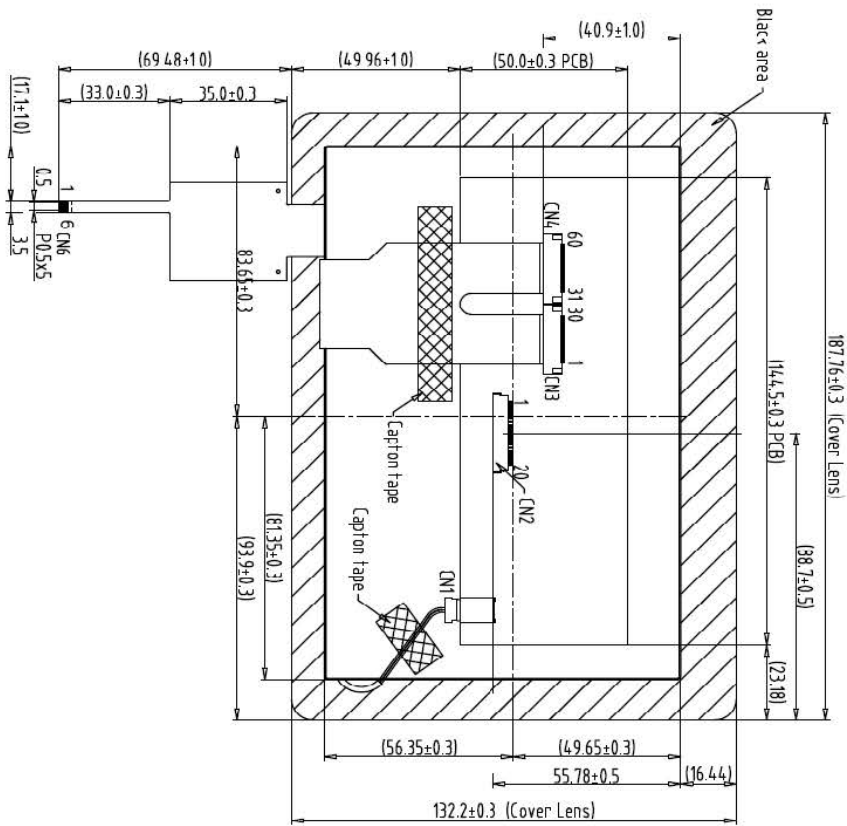

REV	REVISION RECORD	DATE	NAME
0	NEW RELEASE	05-31-13	EMILY
1	TFT-800x480-184A-0 Rename to 800x480RT-T31	06-27-13	EMILY

1	TFT800480-184A-0	7	TOLERANCE GRADE(+)	A	B	DIM.	MM	DWN.	EMILY	DATE	TITLE	DWG. NO.	SHEET
2		8				IE NO.		CHK.		DATE	USMP-T070-0800480CJ-A0	*130583MA	1 OF 1
3		9				PARTS NO.	LCM-1	APPD.		DATE			
4		10											
5		11											
6		12				800480RT-T31							

