



US Micro Products
Electronic Products for the OEM

OLED PRODUCT SPECIFICATION

MANUFACTURED BY RITDISPLAY



PART NUMBER:	USMP-P22102
DESCRIPTION:	1.5", 128x128, White, SSD1327, COG

ISSUE DATE	APPROVED BY (Customer Use Only)	CHECKED BY	PREPARED BY
PROPRIETARY NOTE:	THIS SPECIFICATION IS THE PROPERTY OF US MICRO PRODUCTS AND SHALL NOT BE REPRODUCED OR COPIED WITHOUT THE WRITTEN PERMISSION OF US MICRO PRODUCTS AND MUST BE RETURNED TO US MICRO PRODUCTS UPON ITS REQUEST.		

REVISION RECORD

REV.	REVISION DESCRIPTION	REV. DATE	REMARK
X01	■ INITIAL RELEASE	2008. 07. 10	
X02	<ul style="list-style-type: none"> ■ Modify definition of panel thickness ■ Add lifetime specifications ■ Modify D.C electrical characteristics ■ Add panel electrical specifications ■ Add application circuit 	2009. 04. 24	Page 5, 6, 7, 8 & 16
A01	<ul style="list-style-type: none"> ■ Transfer from X version ■ Add the information of module weight ■ Modify seal color (white→black) ■ Add the packing specification 	2009. 12. 16	Page 5, 18 & 19

CONFIDENTIAL

CONTENTS

ITEM	PAGE
<u>1. SCOPE</u>	4
<u>2. WARRANTY</u>	4
<u>3. FEATURES</u>	4
<u>4. MECHANICAL DATA</u>	5
<u>5. MAXIMUM RATINGS</u>	6
<u>6. ELECTRICAL CHARACTERISTICS</u>	7
6.1 D.C ELECTRICAL CHARACTERISTICS	
6.2 ELECTRO-OPTICAL CHARACTERISTICS	
<u>7. INTERFACE</u>	9
7.1 FUNCTION BLOCK DIAGRAM	
7.2 PANEL LAYOUT DIAGRAM	
7.3 PIN ASSIGNMENTS	
7.4 GRAPHIC DISPLAY DATA RAM ADDRESS MAP	
7.5 INTERFACE TIMING CHART	
<u>8. POWER ON / OFF SEQUENCE & APPLICATION CIRCUIT</u>	15
8.1 POWER ON / OFF SEQUENCE	
8.2 APPLICATION CIRCUIT	
8.3 COMMAND TABLE	
<u>9. RELIABILITY TEST CONDITIONS</u>	17
<u>10. EXTERNAL DIMENSION</u>	18
<u>11. PACKING SPECIFICATION</u>	19
<u>12. APPENDIXES</u>	20

CONFIDENTIAL

1. SCOPE

The purpose of this specification is to define the general provisions and quality requirements that apply to the supply of display cells manufactured by RiTdisplay. This document, together with the Module Assembly Drawing, is the highest-level specification for this product. It describes the product, identifies supporting documents and contains specifications.

2. WARRANTY

RiTdisplay warrants that the products delivered pursuant to this specification (or order) will conform to the agreed specifications for twelve (12) months from the shipping date ("Warranty Period"). RiTdisplay is obligated to repair or replace the products which are found to be defective or inconsistent with the specifications during the Warranty Period without charge, on condition that the products are stored or used as the conditions specified in the specifications. Nevertheless, RiTdisplay is not obligated to repair or replace the products without charge if the defects or inconsistency are caused by the force majeure or the reckless behaviors of the customer.

After the Warranty Period, all repairs or replacements of the products are subject to charge.

3. FEATURES

- Small molecular organic light emitting diode.
- Color : White
- Panel resolution : 128*128
- Driver IC : SSD1327
- Excellent Quick response time : 10 μ s
- Extremely thin thickness for best mechanism design : 1.41 mm
- High contrast : 2000:1
- Wide viewing angle : 160°
- Strong environmental resistance.
- 8-bit 6800-series Parallel Interface, 8-bit 8080-series Parallel Interface, Serial Peripheral Interface, I²C Interface.
- Wide range of operating temperature : -40 to 70°C
- Anti-glare polarizer.

4. MECHANICAL DATA

NO	ITEM	SPECIFICATION	UNIT
1	Dot Matrix	128 x 128	dot
2	Dot Size	0.19 (W) x 0.19 (H)	mm ²
3	Dot Pitch	0.21 (W) x 0.21 (H)	mm ²
4	Aperture Rate	82	%
5	Active Area	26.86 (W) x 26.86 (H)	mm ²
6	Panel Size	33.8 (W) x 36.5 (H)	mm ²
7*	Panel Thickness	1.22 ± 0.1	mm
8	Module Size	33.8 (W) x 43.7 (H) x 1.41 (T)	mm ³
9	Diagonal A/A size	1.5	inch
10	Module Weight	3.48 ± 10%	gram

* Panel thickness includes substrate glass, cover glass and UV glue thickness.

CONFIDENTIAL

5. MAXIMUM RATINGS

ITEM	MIN	MAX	UNIT	Condition	Remark
Supply Voltage (V_{CI})	-0.3	4	V	$T_a = 25^{\circ}\text{C}$	IC maximum rating
Supply Voltage (V_{CC})	8	19	V	$T_a = 25^{\circ}\text{C}$	IC maximum rating
Operating Temp.	-40	70	$^{\circ}\text{C}$		
Storage Temp	-40	85	$^{\circ}\text{C}$		
Humidity		85	%		
Life Time	10,000	-	Hrs	100 cd/m^2 , 50% checkerboard	Note (1)
Life Time	11,000	-	Hrs	90 cd/m^2 , 50% checkerboard	Note (2)
Life Time	12,000	-	Hrs	80 cd/m^2 , 50% checkerboard	Note (3)

Note:

(A) Under $V_{CC} = 15\text{V}$, $T_a = 25^{\circ}\text{C}$, 50% RH.

(B) Life time is defined the amount of time when the luminance has decayed to less than 50% of the initial measured luminance.

(1) Setting of 100 cd/m^2 :

- Contrast setting : 0x9b
- Frame rate : 105Hz
- Duty setting : 1/128

(2) Setting of 90 cd/m^2 :

- Contrast setting : 0x77
- Frame rate : 105Hz
- Duty setting : 1/128

(3) Setting of 80 cd/m^2 :

- Contrast setting : 0x60
- Frame rate : 105Hz
- Duty setting : 1/128

CONFIDENTIAL

6. ELECTRICAL CHARACTERISTICS

6.1 D.C ELECTRICAL CHARACTERISTICS

SYMBOL	PARAMETERS	TEST CONDITION	MIN	TYP	MAX	UNIT
V_{CC}	Driver power supply (for OLED panel)	-	14.5	15	15.5	V
V_{CI}	Low voltage power supply	-	2.6	-	3.5	V
V_{OH}	High logic output level	$I_{out}=100\ \mu A$,	$0.9 \cdot V_{CI}$	-	V_{CI}	V
V_{OL}	Low logic output level	$I_{out}=100\ \mu A$,	0	-	$0.1 \cdot V_{CI}$	V
V_{IH}	High logic input level	$I_{out}=100\ \mu A$,	$0.8 \cdot V_{CI}$	-	V_{CI}	V
V_{IL}	Low logic input level	$I_{out}=100\ \mu A$,	0	-	$0.2 \cdot V_{CI}$	V
I_{CC}	V_{CC} Supply Current	$V_{CI} = 3.5V$, $V_{CC} = 18V$, Display ON, No panel attached, contrast = FF	External $V_{DD} = 2.5V$	600	750	uA
			Internal $V_{DD} = 2.5V$	600	750	
I_{CI}	V_{CI} Supply Current	$V_{CI} = 3.5V$, $V_{CC} = 18V$, Display ON, No panel attached, contrast = FF	External $V_{DD} = 2.5V$	35	50	uA
			Internal $V_{DD} = 2.5V$	95	120	
I_{SEG}	Segment output current Setting $V_{CC}=18V$, $I_{REF}=10\ \mu A$	Contrast=FF	-	300	370	uA
		Contrast=AF	-	206	-	uA
		Contrast=7F	-	150	-	uA
		Contrast=3F	-	75	-	uA
		Contrast=1F	-	37.5	-	uA

CONFIDENTIAL

6.2 ELECTRO-OPTICAL CHARACTERISTICS

PANEL ELECTRICAL SPECIFICATIONS

PARAMETER	MIN	TYP.	MAX	UNITS	COMMENTS
Normal mode current consumption	-	32	34	mA	All pixels on
Standby mode current consumption	-	3	4	mA	Standby mode 10% pixels on
Normal mode power consumption	-	480	510	mW	All pixels on
Standby mode power consumption	-	45	60	mW	Standby mode 10% pixels on
Pixel Luminance	70	90		cd/m ²	Display Average
Standby Luminance		20		cd/m ²	
CIE _x (White)	0.24	0.28	0.32		CIE1931
CIE _y (White)	0.28	0.32	0.36		CIE1931
Dark Room Contrast	2000:1				
Viewing Angle	160			degree	
Response Time		10		μs	

Normal mode condition :

- Driving Voltage : 15V
- Contrast setting : 0x77
- Frame rate : 105Hz
- Duty setting : 1/128

Standby mode condition :

- Driving Voltage : 15V
- Contrast setting : 0x14
- Frame rate : 105Hz
- Duty setting : 1/128

CONFIDENTIAL

7. INTERFACE

7.1 FUNCTION BLOCK DIAGRAM

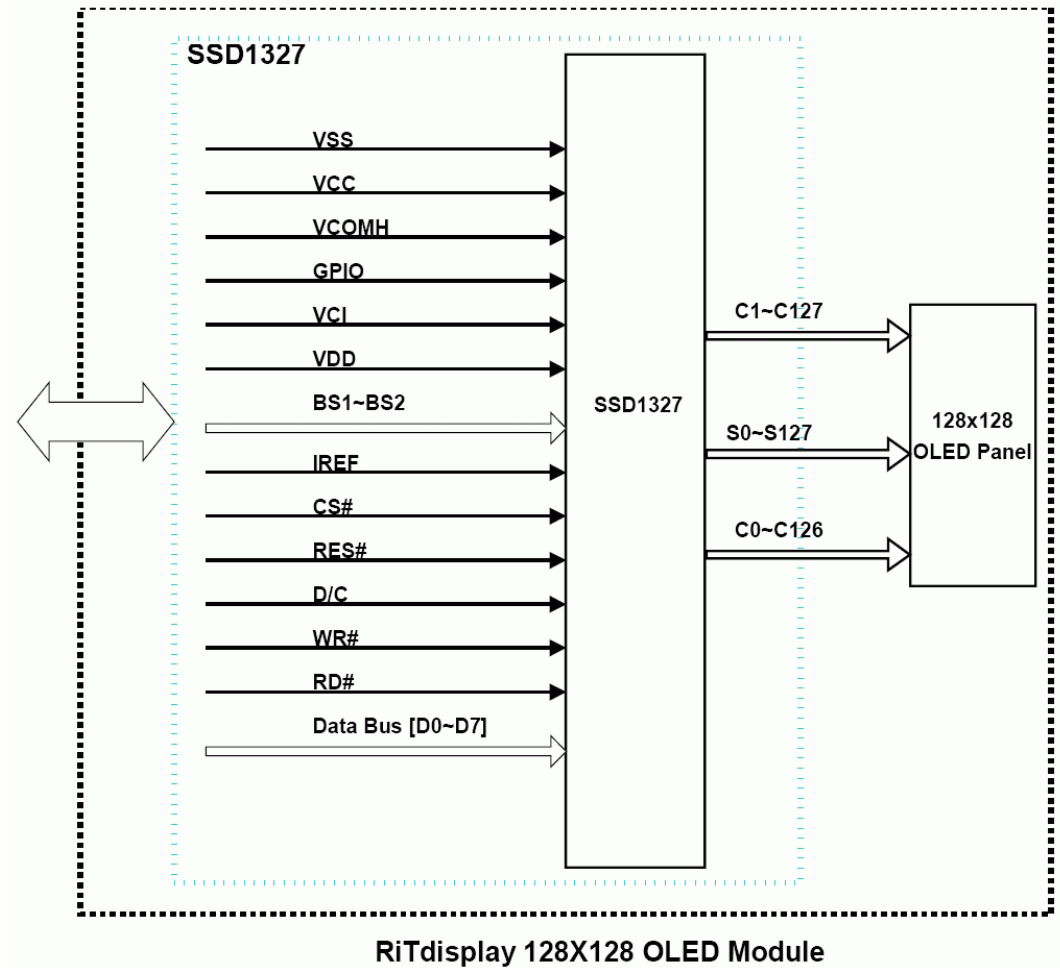

7.2 PANEL LAYOUT DIAGRAM

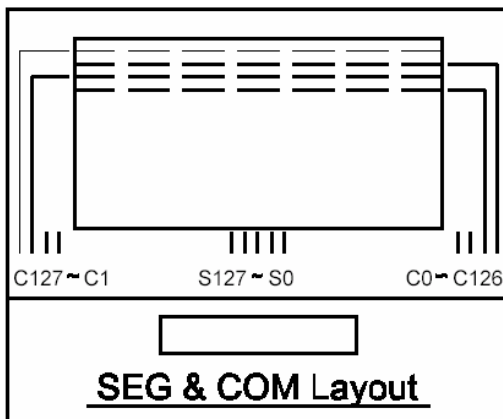

CONFIDENTIAL

7.3 PIN ASSIGNMENTS

PIN NAME	PIN NO	DESCRIPTION
VSS	1	Ground.
VCC	2	Power supply for analog circuit.
VCOMH	3	Com Voltage Output. A capacitor should be connected between this pin and V _{SS} .
GPIO	4	General I/O port.
VCI	5	Power supply for logic circuit.
VDD	6	A capacitor should be connected between this pin and V _{SS} .
BS1	7	MCU bus interface selection pins.
BS2	8	MCU bus interface selection pins.
VSS	9	Ground.
IREF	10	Reference current input pin. A resistor should be connected between this pin and V _{SS} .
CS#	11	Chip select input.
RES#	12	Reset signal input. When it's low, initialization of SSD1327 is executed.
D/C	13	Data/ Command control. Pull high for write/read display data. Pull low for write command or read status.
WR#	14	MCU interface input. Data write operation is initiated when it's pull low.
RD#	15	MCU interface input. Data read operation is initiated when it's pull low.
D0	16	Data bus(for parallel interface)
D1	17	
D2	18	
D3	19	
D4	20	
D5	21	
D6	22	
D7	23	
VCC	24	Power supply for analog circuit.
VSS	25	Ground.

CONFIDENTIAL

7.4 GRAPHIC DISPLAY DATA RAM ADDRESS MAP

The GDDRAM is a bit mapped static RAM holding the bit pattern to be displayed. The size of the RAM is 128x128x4 bits. For mechanical flexibility, re-mapping on both Segment and Common outputs can be selected by software. The GDDRAM address maps below tables show some examples on using the command “Set Re-map” A0h to re-map the GDDRAM. In the following tables, the lower nibble and higher nibble of D0, D1, D2 ... D8189, D8190, D8191 represent the 128x128 data bytes in the GDDRAM.

The GDDRAM map under the following condition:

- Command “Set Re-map” A0h is set to:
 Disable Column Address Re-map (A[0]=0)
 Disable Nibble Re-map (A[1]=0)
 Enable Horizontal Address Increment (A[2]=0)
 Disable COM Re-map (A[4]=0)
- Display Start Line=00h
- Data byte sequence: D0, D1, D2 ... D8191

GDDRAM address map 1

		SEG0	SEG1	SEG2	SEG3		SEG124	SEG125	SEG126	SEG127	SEG Outputs Column Address (HEX)	
		00		01			3E		3F			
COM0	00	D0[3:0]	D0[7:4]	D1[3:0]	D1[7:4]		D62[3:0]	D62[7:4]	D63[3:0]	D63[7:4]		
COM1	01	D64[3:0]	D64[7:4]	D65[3:0]	D65[7:4]		D126[3:0]	D126[7:4]	D127[3:0]	D127[7:4]		
COM126	7E	D8064[3:0]	D8064[7:4]	D8065[3:0]	D8065[7:4]		D8126[3:0]	D8126[7:4]	D8127[3:0]	D8127[7:4]		
COM127	7F	D8128[3:0]	D8128[7:4]	D8129[3:0]	D8129[7:4]		D8190[3:0]	D8190[7:4]	D8191[3:0]	D8191[7:4]		
COM Outputs	Row Address (HEX)											Nibble re-map A[1]=0

CONFIDENTIAL

The GDDRAM map under the following condition:

- Command “Set Re-map” A0h is set to:
 Disable Column Address Re-map (A[0]=0)
 Disable Nibble Re-map (A[1]=0)
 Enable Vertical Address Increment (A[2]=1)
 Disable COM Re-map (A[4]=0)
- Display Start Line=00h
- Data byte sequence: D0, D1, D2 ... D8191

GDDRAM address map 2

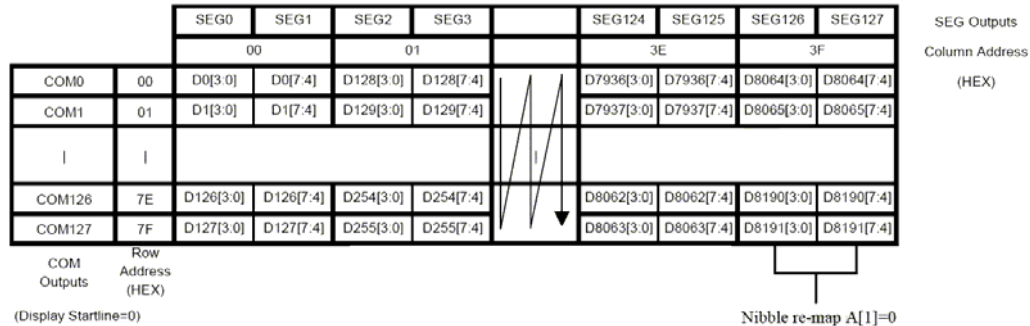

The GDDRAM map under the following condition:

- Command “Set Re-map” A0h is set to:
 Enable Column Address Re-map (A[0]=1)
 Enable Nibble Re-map (A[1]=1)
 Enable Horizontal Address Increment (A[2]=0)
 Disable COM Re-map (A[4]=0)
- Display Start Line=00h
- Data byte sequence: D0, D1, D2 ... D8191

GDDRAM address map 3

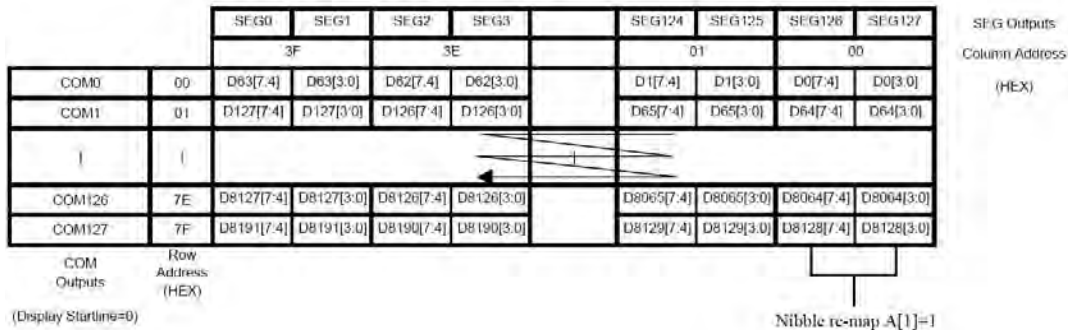

CONFIDENTIAL

The example in which the display start line register is set to 10h with the following condition:

- Command “Set Re-map” A0h is set to:
 Disable Column Address Re-map (A[0]=0)
 Disable Nibble Re-map (A[1]=0)
 Enable Horizontal Address Increment (A[2]=0)
 Enable COM Re-map (A[4]=1)
- Display Start Line=78h (corresponds to COM119)
- Data byte sequence: D0, D1, D2 ... D8191

GDDRAM address map 4

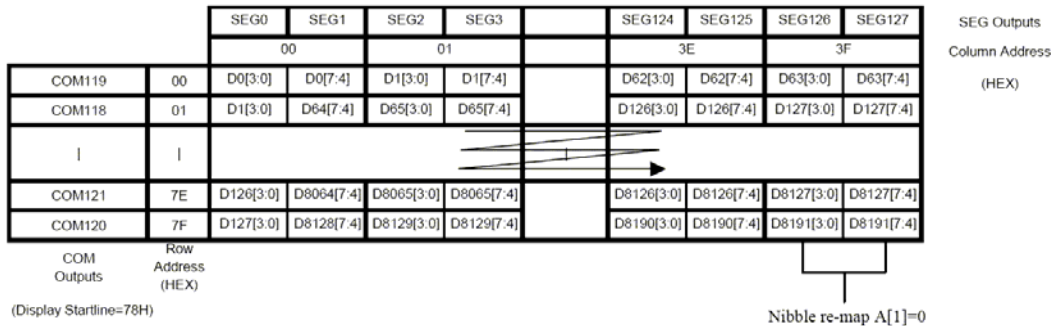

The GDDRAM map under the following condition:

- Command “Set Re-map” A0h is set to:
 Disable Column Address Re-map (A[0]=0)
 Disable Nibble Re-map (A[1]=0)
 Enable Horizontal Address Increment (A[2]=0)
 Disable COM Re-map (A[4]=0)
- Display Start Line=00h
- Column Start Address=01h
- Column End Address=3Eh
- Row Start Address=01h
- Row End Address=7Eh
- Data byte sequence: D0, D1, D2 ... D7811

GDDRAM address map 5

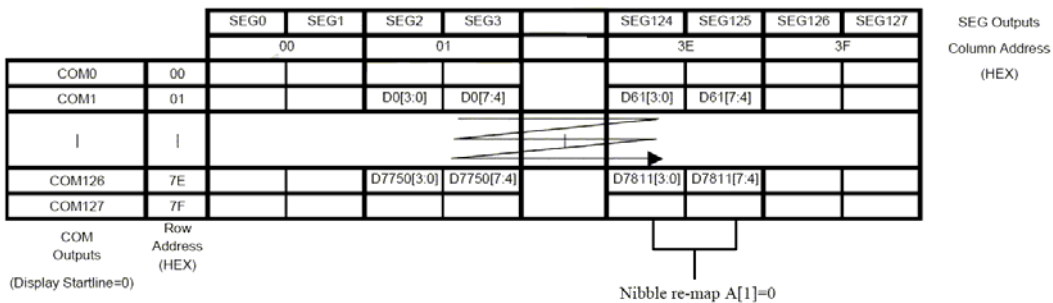

CONFIDENTIAL

7.5 INTERFACE TIMING CHART

8080-Series MCU Parallel Interface Timing Characteristics

($V_{DD} - V_{SS} = 2.4$ to $2.6V$, $V_{CI} = 3.3V$, $T_A = 25^\circ C$)

Symbol	Parameter	Min	Typ	Max	Unit
t_{cycle}	Clock Cycle Time	300	-	-	ns
t_{AS}	Address Setup Time	10	-	-	ns
t_{AH}	Address Hold Time	0	-	-	ns
t_{DSW}	Write Data Setup Time	40	-	-	ns
t_{DHW}	Write Data Hold Time	7	-	-	ns
t_{DHR}	Read Data Hold Time	20	-	-	ns
t_{OH}	Output Disable Time	-	-	70	ns
t_{ACC}	Access Time	-	-	140	ns
$t_{PWL R}$	Read Low Time	150	-	-	ns
$t_{PWL W}$	Write Low Time	60	-	-	ns
$t_{PWH R}$	Read High Time	60	-	-	ns
$t_{PWH W}$	Write High Time	60	-	-	ns
t_R	Rise Time	-	-	15	ns
t_F	Fall Time	-	-	15	ns
t_{CS}	Chip select setup time	0	-	-	ns
t_{CSH}	Chip select hold time to read signal	0	-	-	ns
t_{CSF}	Chip select hold time	20	-	-	ns

8080-series MCU parallel interface characteristics

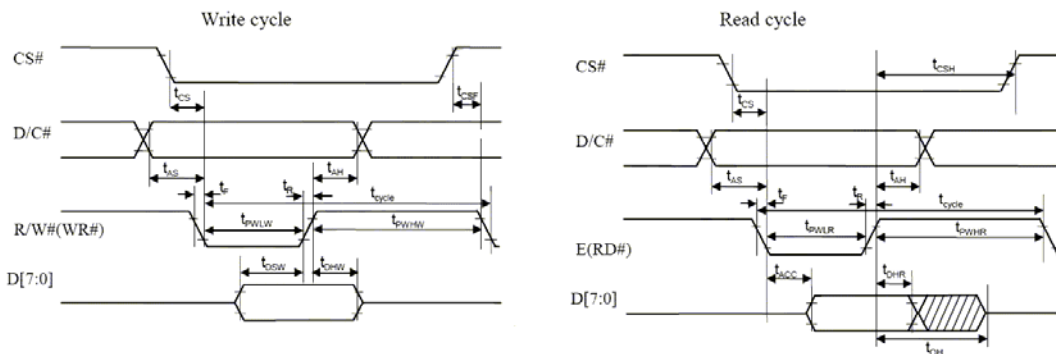

CONFIDENTIAL

8. POWER ON / OFF SEQUENCE & APPLICATION CIRCUIT

8.1 POWER ON / OFF SEQUENCE

Power ON sequence:

1. Power ON V_{CI} .
2. After V_{CI} becomes stable, set wait time at least 1ms (t_0) for internal V_{DD} become stable. Then set RES# pin LOW (logic low) for at least 100us (t_1)⁽⁴⁾ and then HIGH (logic high).
3. After set RES# pin LOW (logic low), wait for at least 100us (t_2). Then Power ON V_{CC} .⁽¹⁾
4. After V_{CC} become stable, send command AFh for display ON. SEG/COM will be ON after 200ms(t_{AF}).

The Power ON sequence.

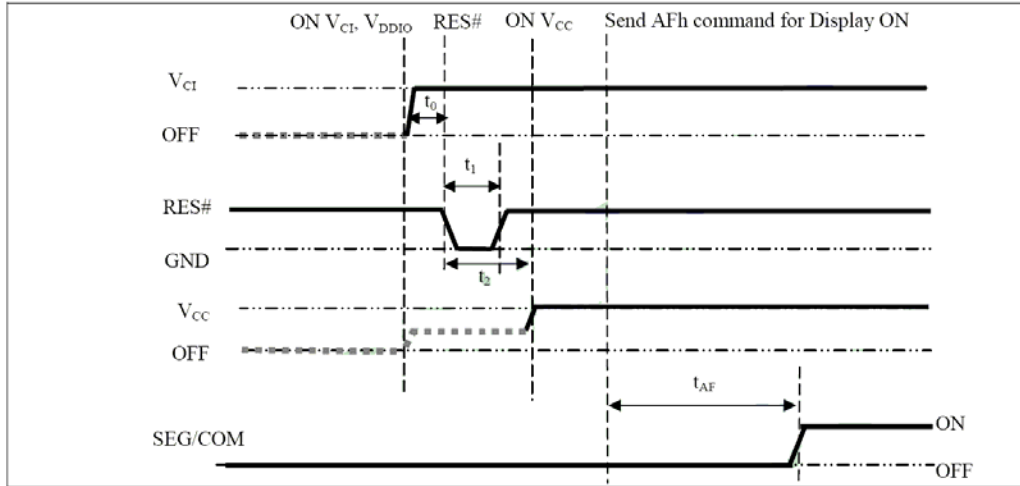

Power OFF sequence:

1. Send command AEh for display OFF.
2. Power OFF V_{CC} .^{(1), (2), (3)}
3. Wait for t_{OFF} . Power OFF V_{CI} . (where Minimum t_{OFF} =80ms⁽⁵⁾, Typical t_{OFF} =100ms)

The Power OFF sequence

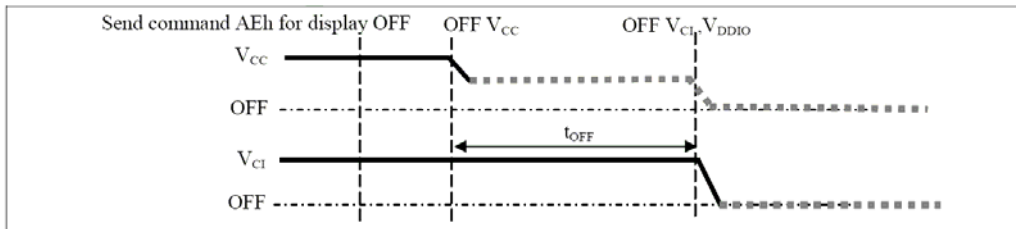

Note:

- (1) Since an ESD protection circuit is connected between V_{CI} and V_{CC} , V_{CC} becomes lower than V_{CI} whenever V_{CI} is ON and V_{CC} is OFF as shown in the dotted line of V_{CC} in above figures.
- (2) V_{CC} should be kept disable when it is OFF.
- (3) Power pins (V_{CI} , V_{CC}) can never be pulled to ground under any circumstance.
- (4) The register values are reset after t_1 .
- (5) V_{CI} should not be Power OFF before V_{CC} Power OFF

CONFIDENTIAL

8.2 APPLICATION CIRCUIT

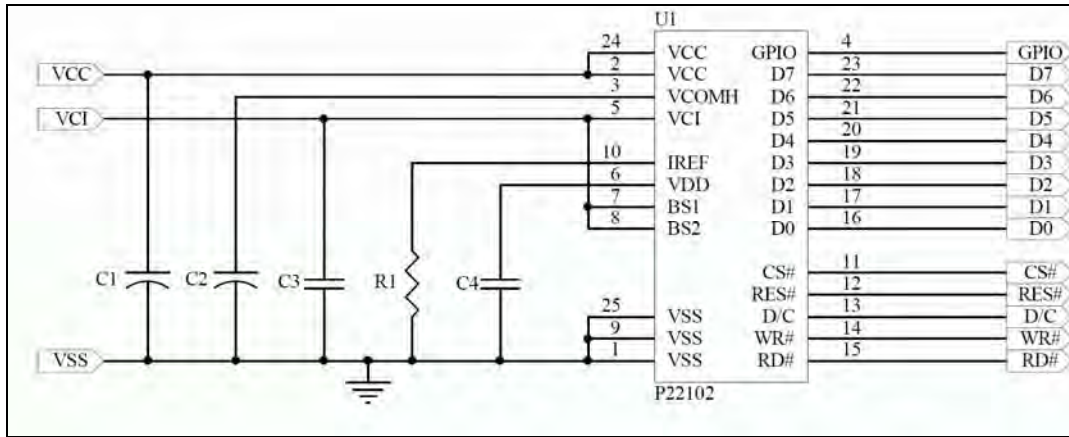

Component:

C1, C2: 4.7uF/35V(Tantalum type) or VISHAY (572D475X0025A2T)

C3, C4: 1uF/16V(0603)

R1: 1M ohm (0603) 1%

This circuit is for 8080 8bits interface.

8.3 COMMAND TABLE

Refer to IC Spec.: SSD1327

CONFIDENTIAL

9. RELIABILITY TEST CONDITIONS

No.	Items	Specification	Quantity
1	High temp. (Non-operation)	85°C, 240hrs	5
2	High temp. (Operation)	70°C, 120hrs	5
3	Low temp. (Operation)	-40°C, 120hrs	5
4	High temp. / High humidity (Operation)	65°C, 90%RH, 120hrs	5
5	Thermal shock (Non-operation)	-40°C ~85°C (-40°C /30min; transit /3min; 85°C /30min; transit /3min) 1cycle: 66min, 100 cycles	5
6	Vibration	Frequency : 5~50HZ, 0.5G Scan rate : 1 oct/min Time : 2 hrs/axis Test axis : X, Y, Z	1 Carton
7	Drop	Height: 120cm Sequence : 1 angle 、 3 edges and 6 faces Cycles: 1	1 Carton
8	ESD (Non-operation)	Air discharge model, ±8kV, 10 times	5

Test and measurement conditions

1. All measurements shall not be started until the specimens attain to temperature stability.
2. All-pixels-on is used as operation test pattern.
3. The degradation of Polarizer are ignored for item 1, 4 & 5.

Evaluation criteria

1. The function test is OK.
2. No observable defects.
3. Luminance: > 50% of initial value.
4. Current consumption: within \pm 50% of initial value.

10. EXTERNAL DIMENSION

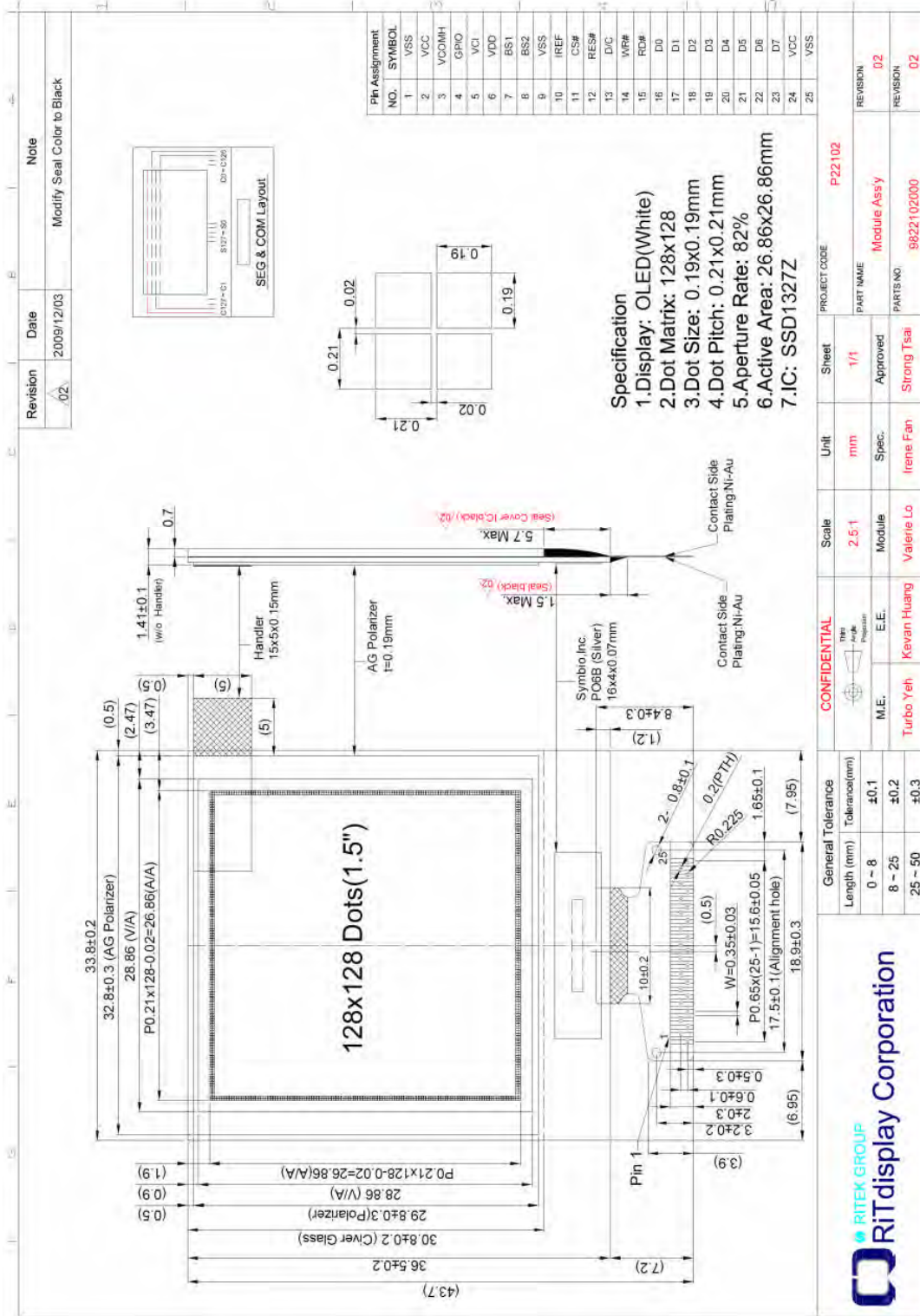

11. PACKING SPECIFICATION

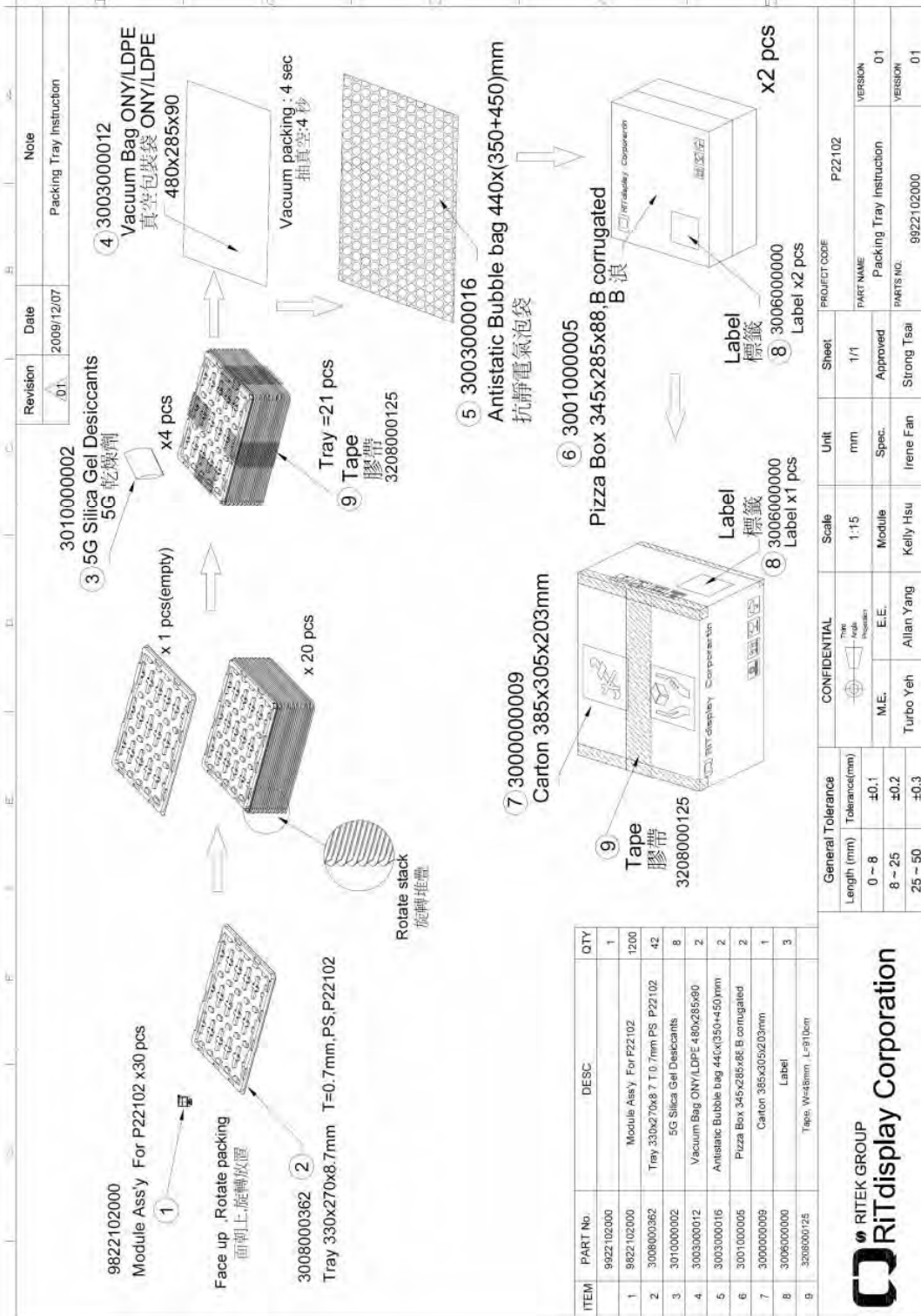

12. APPENDIXES

APPENDIX 1: DEFINITIONS

A. DEFINITION OF CHROMATICITY COORDINATE

The chromaticity coordinate is defined as the coordinate value on the CIE 1931 color chart for R, G, B, W.

B. DEFINITION OF CONTRAST RATIO

The contrast ratio is defined as the following formula:

$$\text{Contrast Ratio} = \frac{\text{Luminance of all pixels on measurement}}{\text{Luminance of all pixels off measurement}}$$

C. DEFINITION OF RESPONSE TIME

The definition of turn-on response time T_r is the time interval between a pixel reaching 10% of steady state luminance and 90% of steady state luminance. The definition of turn-off response time T_f is the time interval between a pixel reaching 90% of steady state luminance and 10% of steady state luminance. It is shown in Figure 2.

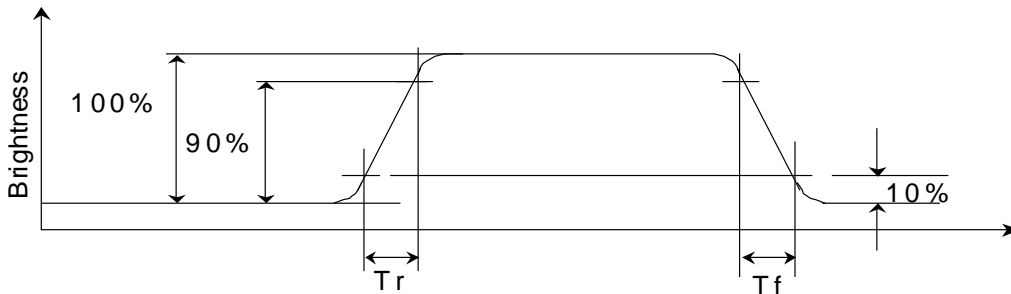

Figure 2 Response time

CONFIDENTIAL

D. DEFINITION OF VIEWING ANGLE

The viewing angle is defined as Figure 3. Horizontal and vertical (H & V) angles are determined for viewing directions where luminance varies by 50% of the perpendicular value.

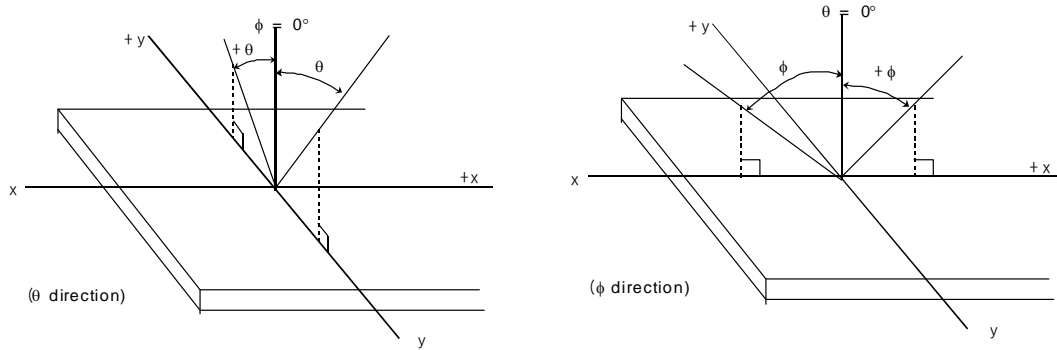

Figure 3 Viewing angle

CONFIDENTIAL

APPENDIX 2: MEASUREMENT APPARATUS

A. LUMINANCE/COLOR COORDINATE

PHOTO RESEARCH PR-705, MINOLTA CS-100

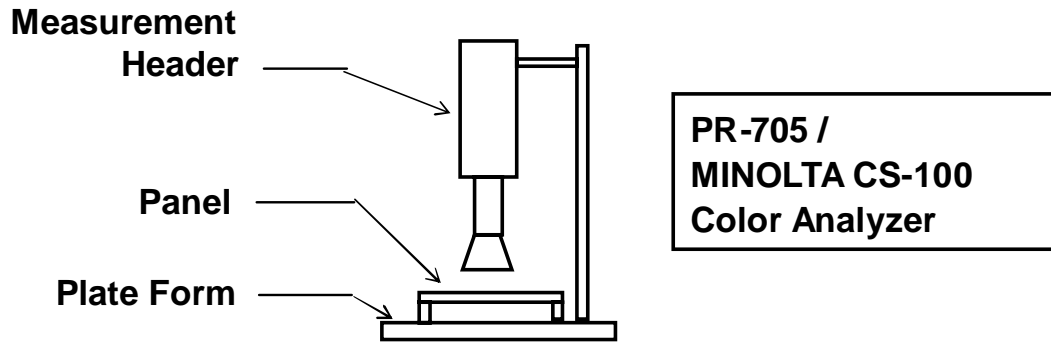

B. CONTRAST / RESPONSE TIME / VIEWING ANGLE

WESTAR CORPORATION FPM-510

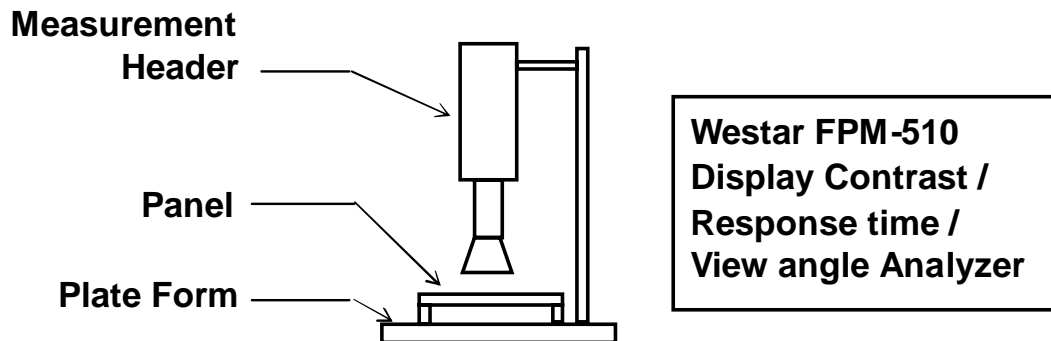

CONFIDENTIAL

C. ESD ON AIR DISCHARGE MODE

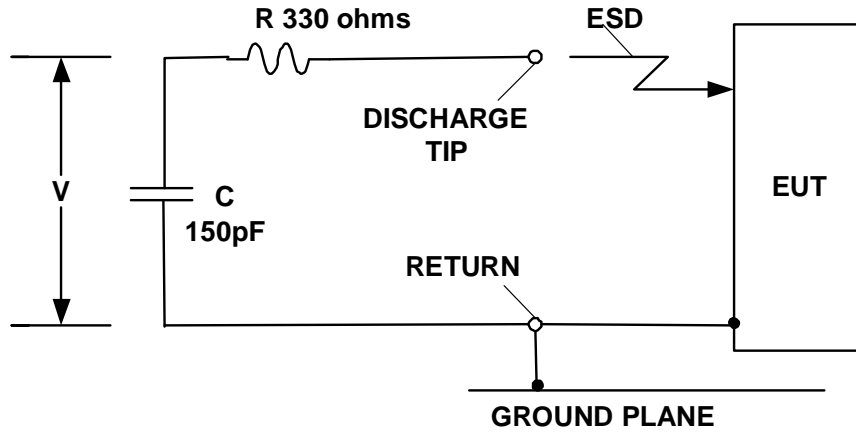

CONFIDENTIAL

APPENDIX 3: PRECAUTIONS

A. RESIDUE IMAGE

Because the pixels are lighted in different time, the luminance of active pixels may reduce or differ from inactive pixels. Therefore, the residue image will occur. To avoid the residue image, every pixel needs to be lighted up uniformly.

CONFIDENTIAL



Displays

US Micro Products is an industrial distributor specializing in engineered display solutions. We dedicate ourselves to providing the best in displays for the medical, industrial, gaming, automotive, aerospace, military and consumer markets.

OLEDs



TFT Display



Open Frame Monitors



Passive LCDs



Multitouch



Touch Screen



As our customer, you receive expert knowledge, support and service. Our technical sales staff and experienced design engineers provide answers to your questions and engineered solutions to meet your display needs.

Peripheral Devices

Our full line of peripheral devices includes keyboards, trackballs and printers. These rugged industrial products are designed to meet the rigorous demands of your equipment and are available in a variety of standard and custom options.

Keyboards



Trackballs



Aerospace Trackballs



Printers

