



US Micro Products
Electronic Products for the OEM

OLED PRODUCT SPECIFICATION

Manufactured by:



PART NUMBER:	USMP-P19301
DESCRIPTION:	2.7" OLED, 128x64, Yellow, Tab, SSD 1305

ISSUE DATE	APPROVED BY (Customer Use Only)	CHECKED BY	PREPARED BY
PROPRIETARY NOTE:	THIS SPECIFICATION IS THE PROPERTY OF US MICRO PRODUCTS AND SHALL NOT BE REPRODUCED OR COPIED WITHOUT THE WRITTEN PERMISSION OF US MICRO PRODUCTS AND MUST BE RETURNED TO US MICRO PRODUCTS UPON ITS REQUEST.		

REVISION RECORD

REV.	REVISION DESCRIPTION	REV. DATE	REMARK
X01	INITIAL RELEASE	2007. 12. 19	
X02	<ul style="list-style-type: none"> ■ Modify typical luminance (80cd/m²→100cd/m²) ■ Add the operating conditions for different luminance ■ Add the panel electrical specifications ■ Modify power off sequence 	2008. 01. 03	Page 6, 7, 8 & 13

CONFIDENTIAL

CONTENTS

ITEM	PAGE
<u>1. SCOPE</u>	4
<u>2. WARRANTY</u>	4
<u>3. FEATURES</u>	4
<u>4. MECHANICAL DATA</u>	5
<u>5. MAXIMUM RATINGS</u>	6
<u>6. ELECTRICAL CHARACTERISTICS</u>	7
6.1 D.C ELECTRICAL CHARACTERISTICS	
6.2 ELECTRO-OPTICAL CHARACTERISTICS	
<u>7. INTERFACE</u>	9
7.1 FUNCTION BLOCK DIAGRAM	
7.2 PANEL LAYOUT DIAGRAM	
7.3 PIN ASSIGNMENTS	
7.4 GRAPHIC DISPLAY DATA RAM ADDRESS MAP	
7.5 INTERFACE TIMING CHART	
<u>8. POWER ON / OFF SEQUENCE & APPLICATION CIRCUIT</u>	13
8.1 POWER ON / OFF SEQUENCE	
8.2 APPLICATION CIRCUIT	
8.3 COMMAND TABLE	
<u>9. RELIABILITY TEST CONDITIONS</u>	15
<u>10. EXTERNAL DIMENSION</u>	16
<u>11. PACKING SPECIFICATION</u>	17
<u>12. APPENDIXES</u>	18

CONFIDENTIAL

1. SCOPE

The purpose of this specification is to define the general provisions and quality requirements that apply to the supply of display cells manufactured by RiTdisplay. This document, together with the Module Ass'y Drawing, is the highest-level specification for this product. It describes the product, identifies supporting documents and contains specifications.

2. WARRANTY

RiTdisplay warrants that the products delivered pursuant to this specification (or order) will conform to the agreed specifications for twelve (12) months from the shipping date ("Warranty Period"). RiTdisplay is obligated to repair or replace the products which are found to be defective or inconsistent with the specifications during the Warranty Period without charge, on condition that the products are stored or used as the conditions specified in the specifications. Nevertheless, RiTdisplay is not obligated to repair or replace the products without charge if the defects or inconsistency are caused by the force majeure or the reckless behaviors of the customer.

After the Warranty Period, all repairs or replacements of the products are subject to charge.

3. FEATURES

- Small molecular organic light emitting diode.
- Color : Yellow
- Panel matrix : 128x64
- Driver IC : SSD1305
- Excellent Quick response time : 10 μ s
- Extremely thin thickness for best mechanism design : 2.01mm
- High contrast : 2000:1
- Wide viewing angle : 160°
- 8-bit 6800-series parallel interface, 8-bit 8080-series parallel interface, serial peripheral interface, I²C interface.
- Wide range of operating temperature : -40 to 70 °C
- Anti-glare polarizer.

4. MECHANICAL DATA

NO	ITEM	SPECIFICATION	UNIT
1	Dot Matrix	128 (W) x 64 (H)	dot
2	Dot Size	0.45 (W) x 0.45 (H)	mm ²
3	Dot Pitch	0.48 (W) x 0.48 (H)	mm ²
4	Aperture Rate	88	%
5	Active Area	61.41 (W) x 30.69 (H)	mm ²
6	Panel Size	70.9 (W) x 41.86 (H)	mm ²
7	Panel Thickness	2.01	mm
8	Module Size	70.9 (W) x 111.61 (H) x 2.01 (T)	mm ³
9	Diagonal A/A size	2.7	inch
10	Module Weight	TBD	gram

CONFIDENTIAL

5. MAXIMUM RATINGS

ITEM	MIN	MAX	UNIT	Condition	Remark
Supply Voltage (V_{DD})	-0.3	3.5	V	Ta = 25°C	IC maximum rating
Supply Voltage (V_{CC})	8	16	V	Ta = 25°C	IC maximum rating
Operating Temp.	-40	70	°C		
Storage Temp	-40	85	°C		
Humidity		85	%		
Life Time	20,000	-	Hrs	120 cd/m ² , 50% checkerboard	Note (1)
Life Time	24,000	-	Hrs	100 cd/m ² , 50% checkerboard	Note (2)
Life Time	30,000	-	Hrs	80 cd/m ² , 50% checkerboard	Note (3)

Note:

(A) Under $V_{CC} = 15VDC$, Ta = 25°C, 50% RH.

(B) Life time is defined the amount of time when the luminance has decayed to less than 50% of the initial measured luminance.

(1) Setting of 120 cd/m² :

- Contrast setting : 0xD0H
- Frame rate : 105Hz
- Duty setting : 1/64

(2) Setting of 100 cd/m² :

- Contrast setting : 0x90H
- Frame rate : 105Hz
- Duty setting : 1/64

(3) Setting of 80 cd/m² :

- Contrast setting : 0x50H
- Frame rate : 105Hz
- Duty setting : 1/64

CONFIDENTIAL

6. ELECTRICAL CHARACTERISTICS

6.1 D.C ELECTRICAL CHARACTERISTICS

SYMBOL	PARAMETERS	TEST CONDITION	MIN	TYP	MAX	UNIT
V_{CC}	Analog power supply (for OLED panel)	-	14.5	15	15.5	V
V_{DD}	Digital power supply	-	2.4	2.7	3.5	V
V_{DDIO}	Logic Supply Voltage for MCU interface	-	1.6	-	V_{DD}	V
I_{DD}	Operating current for V_{DD} $V_{DD} = 2.7V$, $V_{CC} = 12V$, $I_{REF} = 10\mu A$, No panel attached, All Display ON	Contrast=FFh	-	100	300	μA
$I_{CC, SLEEP}$ $I_{DD, SLEEP}$ $I_{DDIO, SLEEP}$	Sleep mode Current	$V_{DD} = 2.4V \sim 3.5V$, $V_{CC} = 7V \sim 15V$ Display OFF, No panel attached	-	-	10	μA
I_{CC}	Operating current for V_{CC} $V_{DD} = 2.7V$, $V_{CC} = 12V$, $I_{REF} = 10\mu A$, No panel attached, All Display ON	Contrast=FFh	-	550	1000	μA
V_{IH}	High logic input level	-	$0.8^* V_{DDIO}$	-	-	V
V_{IL}	Low logic input level	-	0	-	$0.2^* V_{DDIO}$	V
V_{OH}	High logic output level	$I_{OUT} = 100\mu A$, 3.3MHz	$0.9^* V_{DDIO}$	-	-	V
V_{OL}	Low logic output level	$I_{OUT} = 100\mu A$, 3.3MHz	0	-	$0.1^* V_{DDIO}$	V
I_{SEG}	Segment Output Current $V_{DD} = 2.7V$, $V_{CC} = 12V$, $I_{REF} = 10\mu A$, Display on,	Contrast=FFh	294	320	346	μA
		Contrast=AFh	-	220	-	μA
		Contrast=7Fh	-	159	-	μA
		Contrast=3Fh	-	79	-	μA
		Contrast=0Fh	-	19	-	μA

CONFIDENTIAL

6.2 ELECTRO-OPTICAL CHARACTERISTICS

PANEL ELECTRICAL SPECIFICATIONS

PARAMETER	MIN	TYP.	MAX	UNITS	COMMENTS
Normal mode current		28	30	mA	All pixels on (1)
Standby mode current		3	5	mA	Standby mode 10% pixels on (2)
Normal mode power consumption		420	450	mW	All pixels on (1)
Standby mode power consumption		45	75	mW	Standby mode 10% pixels on (2)
Normal mode Luminance	80	100		cd/m ²	Display Average
Standby mode Luminance		60		cd/m ²	Display Average
CIE _x (Yellow)	0.43	0.47	0.51		x, y (CIE 1931)
CIE _y (Yellow)	0.45	0.49	0.53		
Dark Room Contrast	2000:1				
Viewing Angle	160			degree	
Response Time		10		μs	

(1) Normal mode condition :

- Driving Voltage : 15VDC
- Contrast setting : 0x90H
- Frame rate : 105Hz
- Duty setting : 1/64

(2) Standby mode condition :

- Driving Voltage : 15VDC
- Contrast setting : 0x10H
- Frame rate : 105Hz
- Duty setting : 1/64

CONFIDENTIAL

7. INTERFACE

7.1 FUNCTION BLOCK DIAGRAM

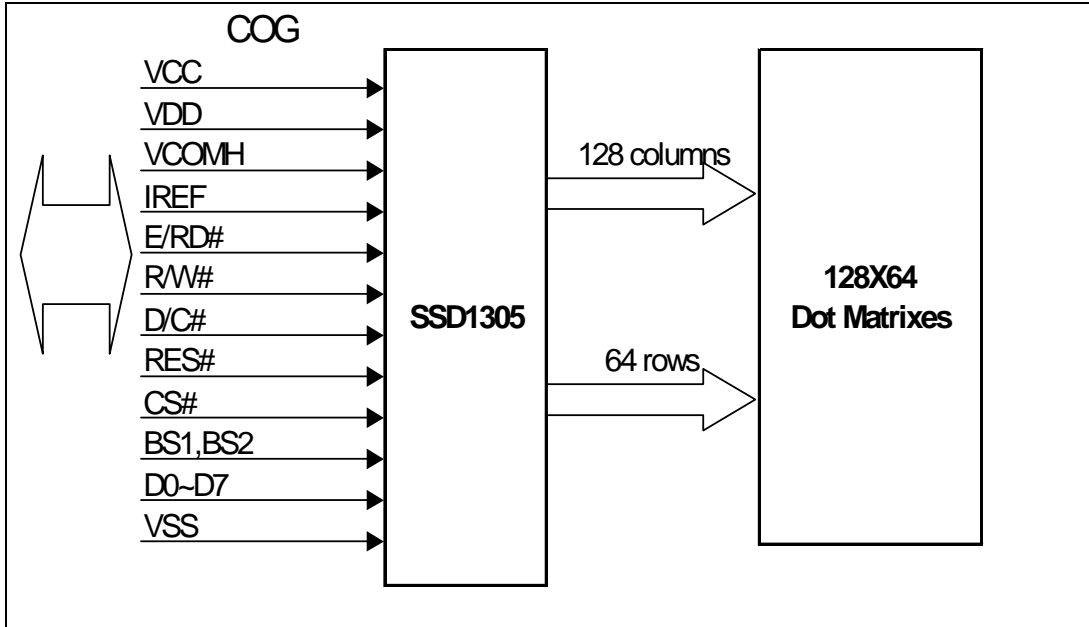

CONFIDENTIAL

7.2 PANEL LAYOUT DIAGRAM

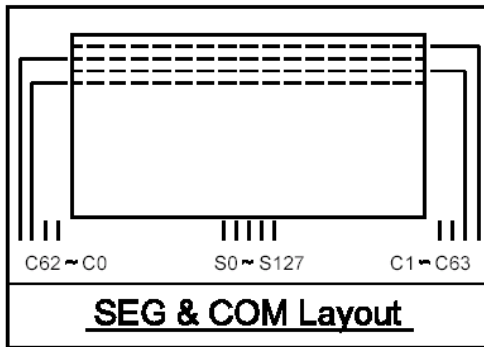

7.3 PIN ASSIGNMENTS

PIN NAME	PIN NO	DESCRIPTION
VCC	1	Power supply for analog circuit.
VCOMH	2	Com Voltage Output. A capacitor should be connected between this pin and VSS.
IREF	3	Reference current input pin. A resistor should be connected between this pin and VSS.
D7	4	Data bus.
D6	5	Data bus.
D5	6	Data bus.
D4	7	Data bus.
D3	8	Data bus.
D2	9	Data bus.
D1	10	Data bus.
D0	11	Data bus.
E/RD#	12	Data read operation is initiated when it' s pull low.
R/W#	13	Data write operation is initiated when it' s pull low.
D/C#	14	Data/ Command control. Pull high for write/read display data. Pull low for write command or read status.
RES#	15	Reset signal input. When it' s low, initialization of SSD1305 is executed.
CS#	16	Chip select input.
BS2	17	Interface select pin.
BS1	18	Interface select pin.
VDD	19	Power supply for logic circuit.
NC	20	No connection.
VSS	21	Ground.
VSS	22	Ground.

CONFIDENTIAL

7.4 GRAPHIC DISPLAY DATA RAM ADDRESS MAP

The GDDRAM is a bit mapped static RAM holding the bit pattern to be displayed. The size of the RAM is 132x64= 8448bits.

For mechanical flexibility, re-mapping on both Segment and Common outputs can be selected by software.

CONFIDENTIAL

Row Address			Column Address	OUT															
OUT	Direction='1'	Direction='0'		Remap='0'	Remap='1'	SEG0	SEG1	SEG2	SEG3	SEG4	SEG5	SEG6	SEG7	...	SEG 128	SEG 129	SEG 130	SEG 131	
COM0	0x3Fh	0x00h	PAGE 0	D0															
COM1	0x3Eh	0x01h		D1															
COM2	0x3Dh	0x02h		D2															
COM3	0x3Ch	0x03h		D3															
COM4	0x3Bh	0x04h		D4															
COM5	0x3Ah	0x05h		D5															
COM6	0x39h	0x06h		D6															
COM7	0x38h	0x07h		D7															
COM8	0x37h	0x08h	PAGE 1	D0															
COM9	0x36h	0x09h		D1															
COM10	0x35h	0x0Ah		D2															
COM11	0x34h	0x0Bh		D3															
COM12	0x33h	0x0Ch		D4															
COM13	0x32h	0x0Dh		D5															
COM14	0x31h	0x0Eh		D6															
COM15	0x30h	0x0Fh		D7															
COM16	0x2Fh	0x10h	PAGE 2	D0															
COM17	0x2Eh	0x11h		D1															
COM18	0x2Dh	0x12h		D2															
COM19	0x2Ch	0x13h		D3															
COM20	0x2Bh	0x14h		D4															
COM21	0x2Ah	0x15h		D5															
COM22	0x29h	0x16h		D6															
COM23	0x28h	0x17h		D7															
COM48	0x0Fh	0x30h	PAGE 6	D0															
COM49	0x0Eh	0x31h		D1															
COM50	0x0Dh	0x32h		D2															
COM51	0x0Ch	0x33h		D3															
COM52	0x0Bh	0x34h		D4															
COM53	0x0Ah	0x35h		D5															
COM54	0x09h	0x36h		D6															
COM55	0x08h	0x37h		D7															
COM56	0x07h	0x38h	PAGE 7	D0															
COM57	0x06h	0x39h		D1															
COM58	0x05h	0x3Ah		D2															
COM59	0x04h	0x3Bh		D3															
COM60	0x03h	0x3Ch		D4															
COM61	0x02h	0x3Dh		D5															
COM62	0x01h	0x3Eh		D6															
COM63	0x00h	0x3Fh		D7															

7.5 INTERFACE TIMING CHART

8080-Series MCU Parallel Interface Timing Characteristics

($V_{DD} - V_{SS} = 2.4V$ to $3.5V$, $V_{DDIO} = V_{DD}$, $T_A = 25^\circ C$)

Symbol	Parameter	Min	Typ	Max	Unit
t_{cycle}	Clock Cycle Time	300	-	-	ns
t_{AS}	Address Setup Time	10	-	-	ns
t_{AH}	Address Hold Time	0	-	-	ns
t_{DSW}	Write Data Setup Time	40	-	-	ns
t_{DHW}	Write Data Hold Time	7	-	-	ns
t_{DHR}	Read Data Hold Time	20	-	-	ns
t_{OH}	Output Disable Time	-	-	70	ns
t_{ACC}	Access Time	-	-	140	ns
t_{PWLR}	Read Low Time	120	-	-	ns
t_{PWLW}	Write Low Time	60	-	-	ns
t_{PWHR}	Read High Time	60	-	-	ns
t_{PWHW}	Write High Time	60	-	-	ns
t_R	Rise Time	-	-	15	ns
t_F	Fall Time	-	-	15	ns
t_{CS}	Chip select setup time	0	-	-	ns
t_{CSH}	Chip select hold time to read signal	0	-	-	ns
t_{CSF}	Chip select hold time	20	-	-	ns

8080-series parallel interface characteristics (Form 1)

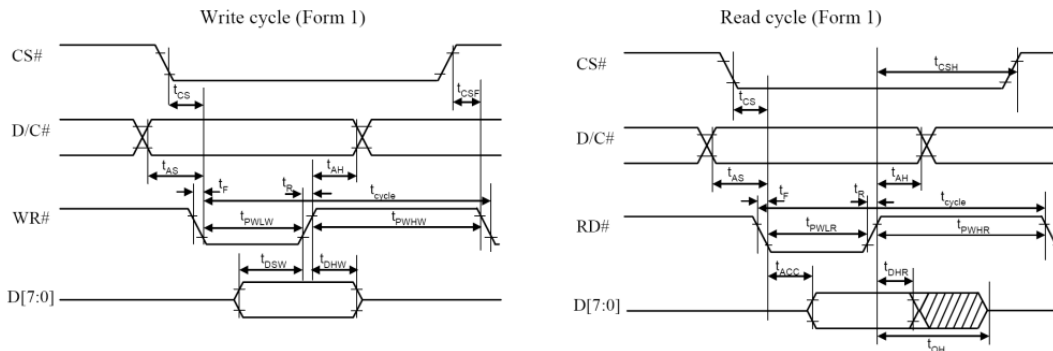

8080-series parallel interface characteristics (Form 2)

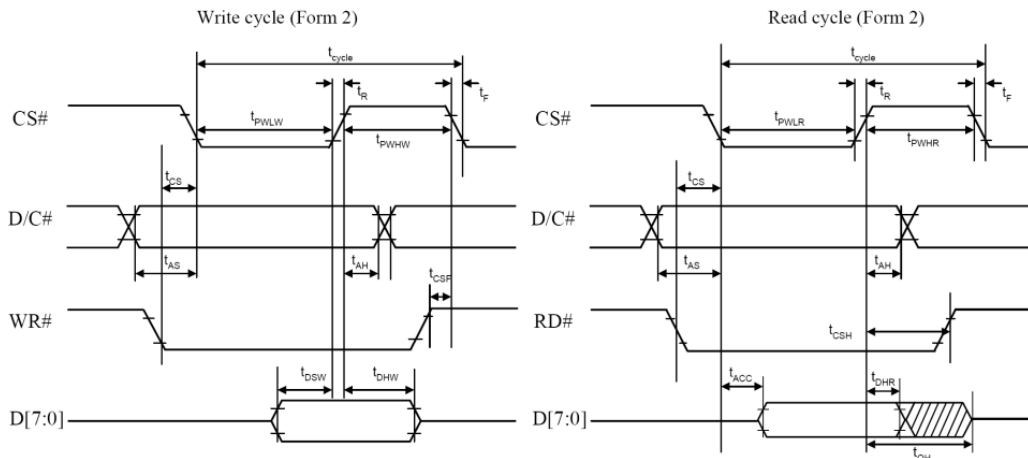

CONFIDENTIAL

8. POWER ON / OFF SEQUENCE & APPLICATION CIRCUIT

8.1 POWER ON / OFF SEQUENCE

Power ON sequence:

1. Power ON V_{DD} , V_{DDIO} .
2. After V_{DD} , V_{DDIO} become stable, set RES# pin LOW (logic low) for at least $3\mu s(t_1)$ and then HIGH (logic high).
3. After set RES# pin LOW (logic low), wait for at least $3\mu s(t_2)$. Then Power ON V_{CC} .(1)
4. After V_{CC} become stable, send command AFh for display ON. SEG/COM will be ON after $100ms(t_{AF})$.

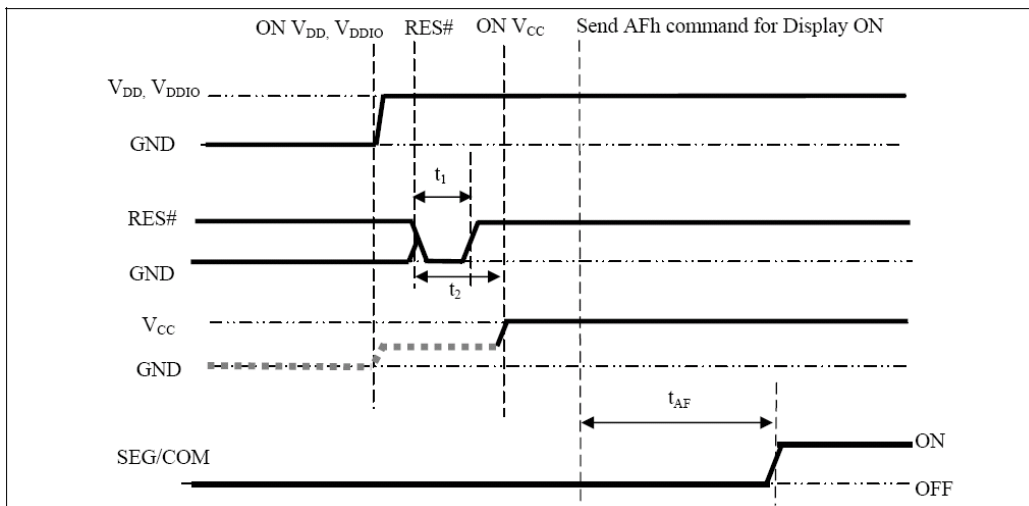

Power OFF sequence:

1. Send command AEh for display OFF.
2. Power OFF V_{CC} . (1), (2)
3. Wait for t_{OFF} . Power OFF V_{DD} , V_{DDIO} . (where Minimum $t_{OFF}=80ms$, Typical $t_{OFF}=100ms$)

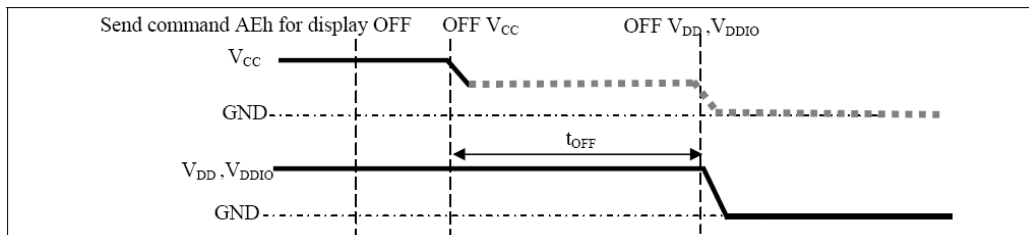

Note:

- (1) Since an ESD protection circuit is connected between V_{DD} , V_{DDIO} and V_{CC} , V_{CC} becomes lower than V_{DD} whenever V_{DD} , V_{DDIO} is ON and V_{CC} is OFF as shown in the dotted line of V_{CC} in above figures.
- (2) V_{CC} should be disabled when it is OFF.

8.2 APPLICATION CIRCUIT

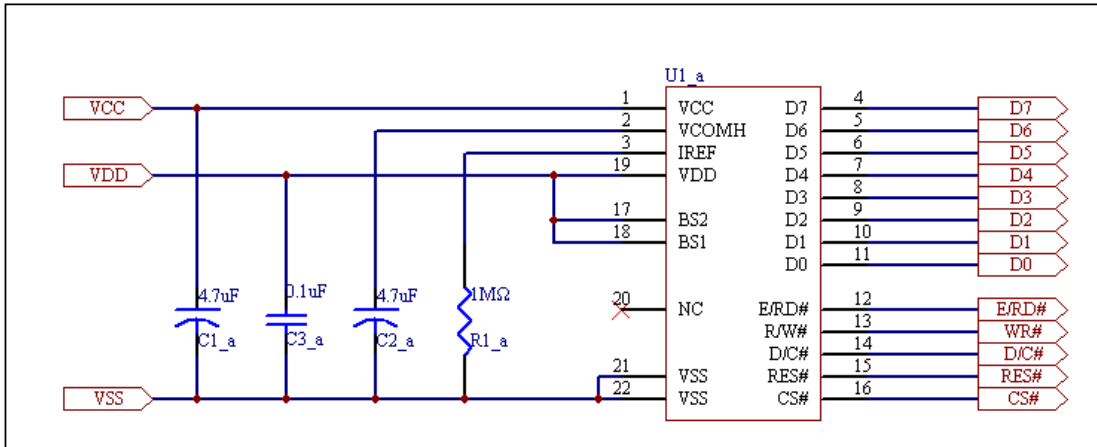

8.3 COMMAND TABLE

Refer to SSD1305 IC Spec.

CONFIDENTIAL

9. RELIABILITY TEST CONDITIONS

No.	Items	Specification	Quantity
1	High temp. (Non-operation)	85°C, 240hrs	5
2	High temp. (Operation)	70°C, 120hrs	5
3	Low temp. (Operation)	-40°C, 120hrs	5
4	High temp. / High humidity (Operation)	65°C, 90%RH, 120hrs	5
5	Thermal shock (Non-operation)	-40°C ~85°C (-40°C /30min; transit /3min; 85°C /30min; transit /3min) 1cycle: 66min, 100 cycles	5
6	Vibration	Frequency : 5~50HZ, 0.5G Scan rate : 1 oct/min Time : 2 hrs/axis Test axis : X, Y, Z	1 Carton
7	Drop	Height: 120cm Sequence : 1 angle 、 3 edges and 6 faces Cycles: 1	1 Carton
8	ESD (Non-operation)	Air discharge model, ±8kV, 10 times	5

Test and measurement conditions

1. All measurements shall not be started until the specimens attain to temperature stability.
2. All-pixels-on is used as operation test pattern.
3. The degradation of Polarizer are ignored for item 1, 4 & 5.

Evaluation criteria

1. The function test is OK.
2. No observable defects.
3. Luminance: > 50% of initial value.
4. Current consumption: within $\pm 50\%$ of initial value.

10. EXTERNAL DIMENSION

CONFIDENTIAL

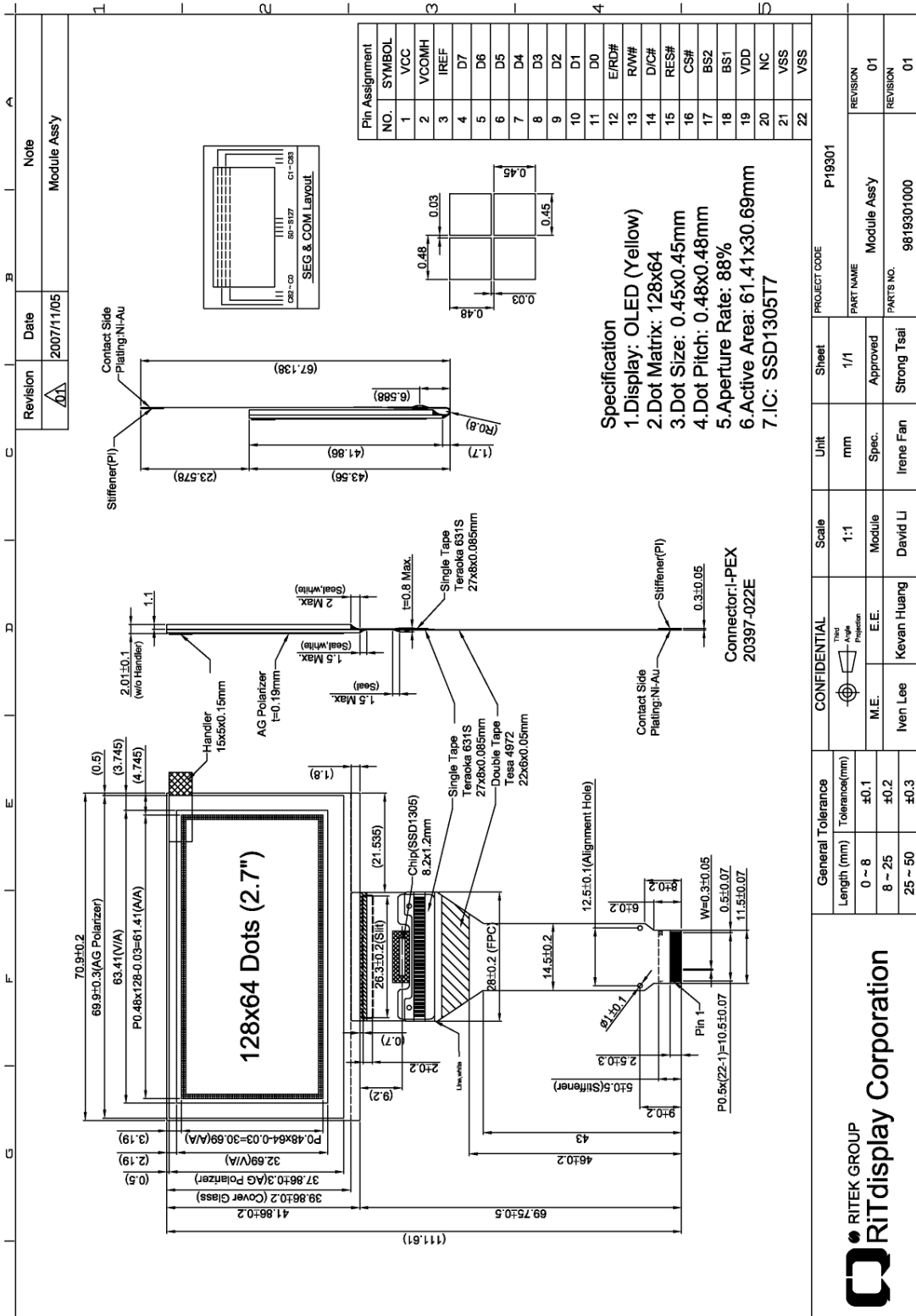

11. PACKING SPECIFICATION

TBD

CONFIDENTIAL

12. APPENDIXES

APPENDIX 1: DEFINITIONS

A. DEFINITION OF CHROMATICITY COORDINATE

The chromaticity coordinate is defined as the coordinate value on the CIE 1931 color chart for R, G, B, W.

B. DEFINITION OF CONTRAST RATIO

The contrast ratio is defined as the following formula:

$$\text{Contrast Ratio} = \frac{\text{Luminance of all pixels on measurement}}{\text{Luminance of all pixels off measurement}}$$

C. DEFINITION OF RESPONSE TIME

The definition of turn-on response time T_r is the time interval between a pixel reaching 10% of steady state luminance and 90% of steady state luminance. The definition of turn-off response time T_f is the time interval between a pixel reaching 90% of steady state luminance and 10% of steady state luminance. It is shown in Figure 2.

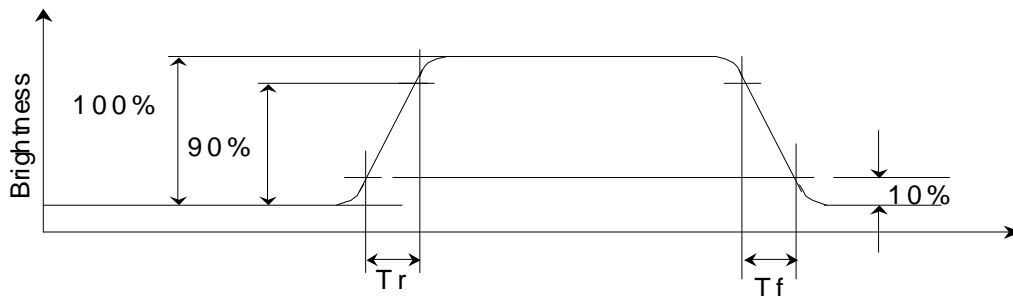

Figure 2 Response time

CONFIDENTIAL

D. DEFINITION OF VIEWING ANGLE

The viewing angle is defined as Figure 3. Horizontal and vertical (H & V) angles are determined for viewing directions where luminance varies by 50% of the perpendicular value.

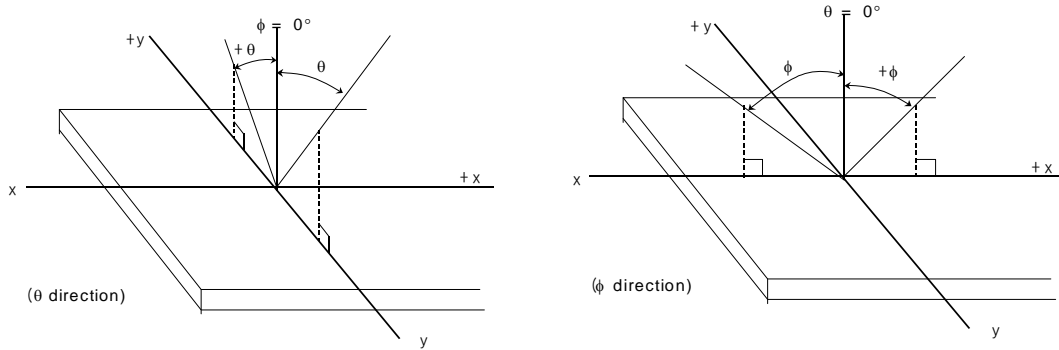

Figure 3 Viewing angle

CONFIDENTIAL

APPENDIX 2: MEASUREMENT APPARATUS

A. LUMINANCE/COLOR COORDINATE

PHOTO RESEARCH PR-705, MINOLTA CS-100

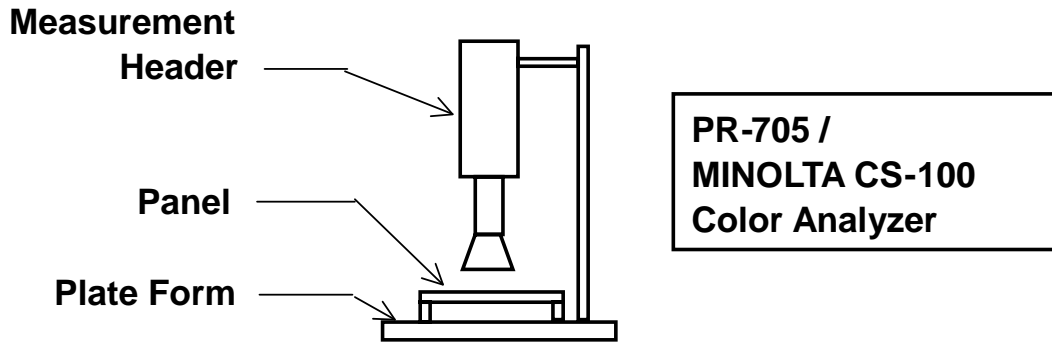

B. CONTRAST / RESPONSE TIME / VIEW ANGLE

WESTAR CORPORATION FPM-510

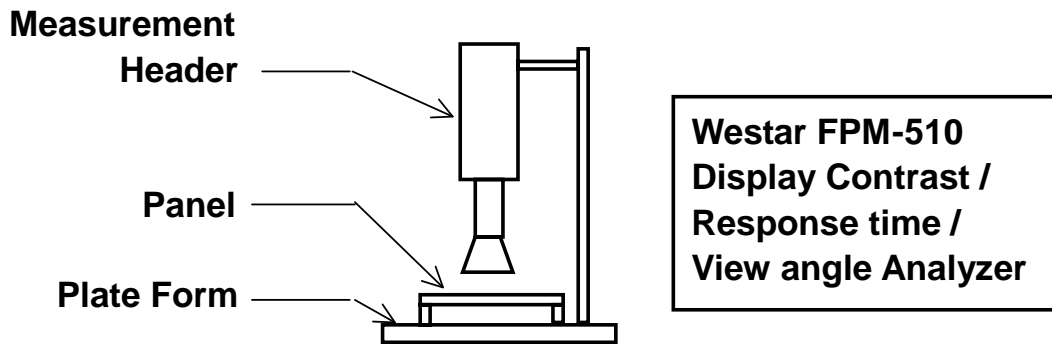

CONFIDENTIAL

C. ESD ON AIR DISCHARGE MODE

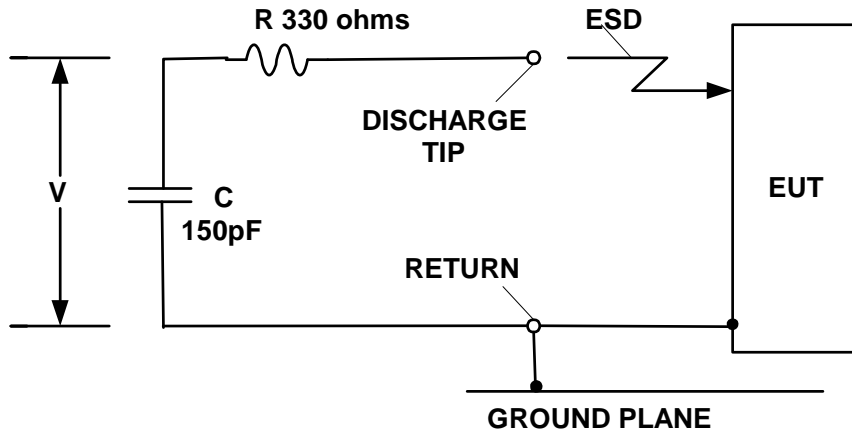

CONFIDENTIAL

APPENDIX 3: PRECAUTIONS

A. RESIDUE IMAGE

Because the pixels are lighted in different time, the luminance of active pixels may reduce or differ from inactive pixels. Therefore, the residue image will occur. To avoid the residue image, every pixel needs to be lighted up uniformly.

CONFIDENTIAL



Displays

US Micro Products is an industrial distributor specializing in engineered display solutions. We dedicate ourselves to providing the best in displays for the medical, industrial, gaming, automotive, aerospace, military and consumer markets.

OLEDs



TFT Display



Open Frame Monitors



Passive LCDs



Multitouch



Touch Screen



As our customer, you receive expert knowledge, support and service. Our technical sales staff and experienced design engineers provide answers to your questions and engineered solutions to meet your display needs.

Peripheral Devices

Our full line of peripheral devices includes keyboards, trackballs and printers. These rugged industrial products are designed to meet the rigorous demands of your equipment and are available in a variety of standard and custom options.

Keyboards



Trackballs



Aerospace Trackballs



Printers

