



US Micro Products
Electronic Products for the OEM

TFT-LCD PRODUCT SPECIFICATION

Manufactured by



PART NUMBER:	USMP-G121SN01 V3
DESCRIPTION:	12.1" TFT LCD with SVGA (800(H) x 600(V)) screen and 16.2M (RGB 8-bits) or 262K colors (RGB 6-bits).

ISSUE DATE	APPROVED BY (Customer Use Only)	CHECKED BY	PREPARED BY
PROPRIETARY NOTE:	THIS SPECIFICATION IS THE PROPERTY OF US MICRO PRODUCTS AND SHALL NOT BE REPRODUCED OR COPIED WITHOUT THE WRITTEN PERMISSION OF US MICRO PRODUCTS AND MUST BE RETURNED TO US MICRO PRODUCTS UPON ITS REQUEST.		



Contents

- 1. Operating Precautions.....4**
- 2. General Description5**
 - 2.1 Display Characteristics5
 - 2.2 Optical Characteristics6
- 3. Functional Block Diagram.....9**
- 4. Absolute Maximum Ratings10**
 - 4.1 Absolute Ratings of TFT LCD Module10
 - 4.2 Absolute Ratings of Environment10
- 5. Electrical Characteristics11**
 - 5.1 TFT LCD Module11
 - 5.2 Backlight Unit13
- 6. Signal Characteristic15**
 - 6.1 Pixel Format Image15
 - 6.2 Scanning Direction15
 - 6.3 Signal Description16
 - LVDS Signal Format:6.4 The Input Data Format17
 - 6.4 The Input Data Format18
 - 6.5 Interface Timing19
 - 6.6 Power ON/OFF Sequence20
- 7. Connector & Pin Assignment21**
 - 7.1 TFT LCD Module: LVDS Connector21
 - 7.2 Backlight Unit: Lamp Connector21
- 8. Reliability Test Criteria22**
- 9. Mechanical Characteristics.....23**
 - 9.1 LCM Outline Dimension (Front View)23
 - 9.2 LCM Outline Dimension (Rear View).....24
 - 9.3 Screw Hole Depth and Center Position.....25
- 10. Label and Packaging.....26**
 - 10.1 Shipping Label (on the rear side of TFT-LCD display)26
 - 10.2 Carton Package26
- 11. Safety.....27**
 - 11.1 Sharp Edge Requirements27
 - 11.2 Materials27
 - 11.3 Capacitors27
 - 11.4 National Test Lab Requirement27

CONFIDENTIAL



Record of Revision

Version and Date	Page	Old Description	New Description	Remark
0.0 2007/11/07	All	First Draft	All	

CONFIDENTIAL



1. Operating Precautions

- 1) Since front polarizer is easily damaged, please be cautious and not to scratch it.
- 2) Be sure to turn off power supply when inserting or disconnecting from input connector.
- 3) Wipe off water drop immediately. Long contact with water may cause discoloration or spots.
- 4) When the panel surface is soiled, wipe it with absorbent cotton or soft cloth.
- 5) Since the panel is made of glass, it may be broken or cracked if dropped or bumped on hard surface.
- 6) Since CMOS LSI is used in this module, take care of static electricity and insure human earth when handling.
- 7) Do not open nor modify the module assembly.
- 8) Do not press the reflector sheet at the back of the module to any direction.
- 9) In case if a module has to be put back into the packing container slot after it was taken out from the container, do not press the center of the CCFL Reflector edge. Instead, press at the far ends of the CCFL Reflector edge softly. Otherwise the TFT Module may be damaged.
- 10) At the insertion or removal of the Signal Interface Connector, be sure not to rotate nor tilt the Interface Connector of the TFT Module.
- 11) After installation of the TFT Module into an enclosure (Notebook PC Bezel, for example), do not twist nor bend the TFT Module even momentary. At designing the enclosure, it should be taken into consideration that no bending/twisting forces are applied to the TFT Module from outside. Otherwise the TFT Module may be damaged.
- 12) Cold cathode fluorescent lamp in LCD contains a small amount of mercury. Please follow local ordinances or regulations for disposal.
- 13) Small amount of materials having no flammability grade is used in the LCD module. The LCD module should be supplied by power complied with requirements of Limited Power Source (IEC60950 or UL1950), or be applied exemption.
- 14) The LCD module is designed so that the CCFL in it is supplied by Limited Current Circuit (IEC60950 or UL1950). Do not connect the CCFL in Hazardous Voltage Circuit.
- 15) Severe temperature condition may result in different luminance, response time and lamp ignition voltage.
- 16) Continuous operating TFT-LCD display under low temperature environment may accelerate lamp exhaustion and reduce luminance dramatically.
- 17) The data on this specification sheet is applicable when LCD module is placed in landscape position.
- 18) Continuous displaying fixed pattern may induce image sticking. It's recommended to use screen saver or shuffle content periodically if fixed pattern is displayed on the screen.

CONFIDENTIAL



2. General Description

G121SN01 V3 is a Color Active Matrix Liquid Crystal Display composed of a TFT-LCD display, a driver circuit, and a backlight system. The screen format is intended to support SVGA (800(H) x 600(V)) screen and 16.2M (RGB 8-bits) or 262K colors (RGB 6-bits). All input signals are LVDS interface compatible. Inverter card of backlight is not included.

G121SN01 V3 is designed for industrial display applications.

2.1 Display Characteristics

The following items are characteristics summary on the table under 25 °C condition:

Items	Unit	Specifications
Screen Diagonal	[inch]	12.1
Active Area	[mm]	246.0(H) x 184.5(V)
Pixels H x V		800x3(RGB) x 600
Pixel Pitch	[mm]	0.3075 x 0.3075
Pixel Arrangement		R.G.B. Vertical Stripe
Display Mode		TN, Normally White
Nominal Input Voltage VDD	[Volt]	3.3 typ.
Typical Power Consumption	[Watt]	7.8W (64 Gray Bar Pattern, exclude inverter)
Weight	[Grams]	660g (typ.)
Physical Size	[mm]	279.0(H)x 209.0(V) x 11.0(D) (typ.)
Electrical Interface		1 channel LVDS
Surface Treatment		AG, Hardness 3H
Support Color		16.2M/262K colors
Temperature Range Operating Storage (Non-Operating)	[°C] [°C]	-30 to +85 (+85°C as panel surface temperature) -30 to +85
RoHS Compliance		RoHS Compliance

CONFIDENTIAL



2.2 Optical Characteristics

The optical characteristics are measured under stable conditions at 25 °C (Room Temperature):

Item	Unit	Conditions	Min.	Typ.	Max.	Note
White Luminance	[cd/m ²]	IRCFL= 6.0mA (center point)	320	400	-	1
Uniformity		13 Points	-	1.25	1.60	1, 2, 3,
Contrast Ratio			-	600	-	4
Response Time	[msec]	Rising	-	10	20	5
	[msec]	Falling	-	25	30	5
	[msec]	Rising + Falling	-	35	50	6
Viewing Angle	[degree]	Horizontal (Right)	60	70	-	6
	[degree]	CR = 10 (Left)	60	70	-	
	[degree]	Vertical (Upper)	45	50	-	6
[degree]	CR = 10 (Lower)	55	60	-		
Color / Chromaticity Coordinates (CIE 1931)	%	Red x	0.590	0.620	0.650	
		Red y	0.310	0.340	0.370	
		Green x	0.275	0.305	0.335	
		Green y	0.555	0.585	0.615	
		Blue x	0.115	0.145	0.175	
		Blue y	0.112	0.115	0.118	
		White x	0.283	0.313	0.343	
		White y	0.299	0.329	0.359	
Color Gamut				55		

CONFIDENTIAL

Note 1: Measurement method

Equipment Pattern Generator, Power Supply, Digital Voltmeter, Luminance meter (SR_3 or equivalent)

Aperture 1° with 50cm viewing distance

Test Point Center

Environment < 1 lux

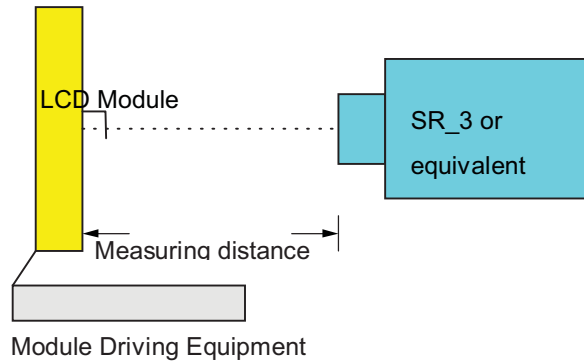

Note 2: Definition of 13 points position

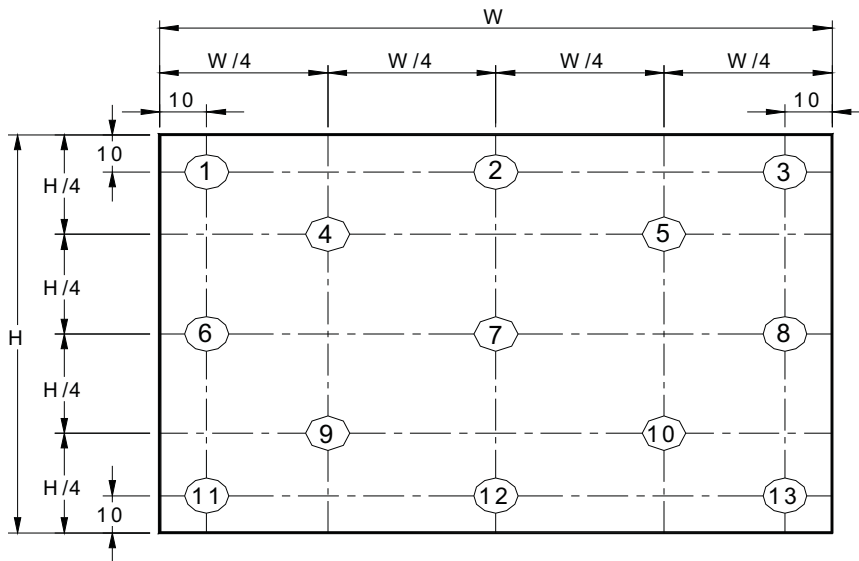

Note 3: The luminance uniformity of 13 points is defined by dividing the minimum luminance values by the maximum test point luminance.

$$\delta_{w13} = \frac{\text{Maximum Brightness of Thirteen Points}}{\text{Minimum Brightness of Thirteen Points}}$$

CONFIDENTIAL



Note 4: Definition of contrast ratio (CR):

$$\text{Contrast ratio (CR)} = \frac{\text{Brightness on the "White" state}}{\text{Brightness on the "Black" state}}$$

Note 5: Definition of response time:

The output signals of photo detector are measured when the input signals are changed from "White" to "Black" (falling time) and from "Black" to "White" (rising time), respectively. The response time interval is between 10% and 90% of amplitudes. Please refer to the figure as below.

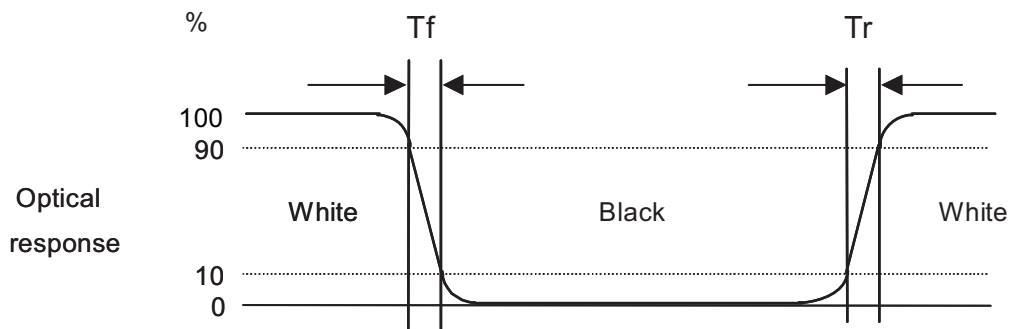

Note 6: Definition of viewing angle

Viewing angle is the measurement of contrast ratio ≥ 10 , at the screen center, over a 180° horizontal and 180° vertical range (off-normal viewing angles). The 180° viewing angle range is broken down as below: 90° (θ) horizontal left and right, and 90° (Φ) vertical high (up) and low (down). The measurement direction is typically perpendicular to the display surface with the screen rotated to its center to develop the desired measurement viewing angle.

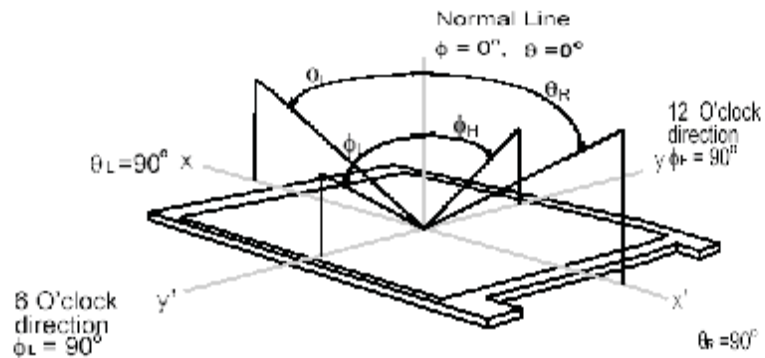

CONFIDENTIAL

3. Functional Block Diagram

The following diagram shows the functional block of the 12.1 inch color TFT/LCD module:

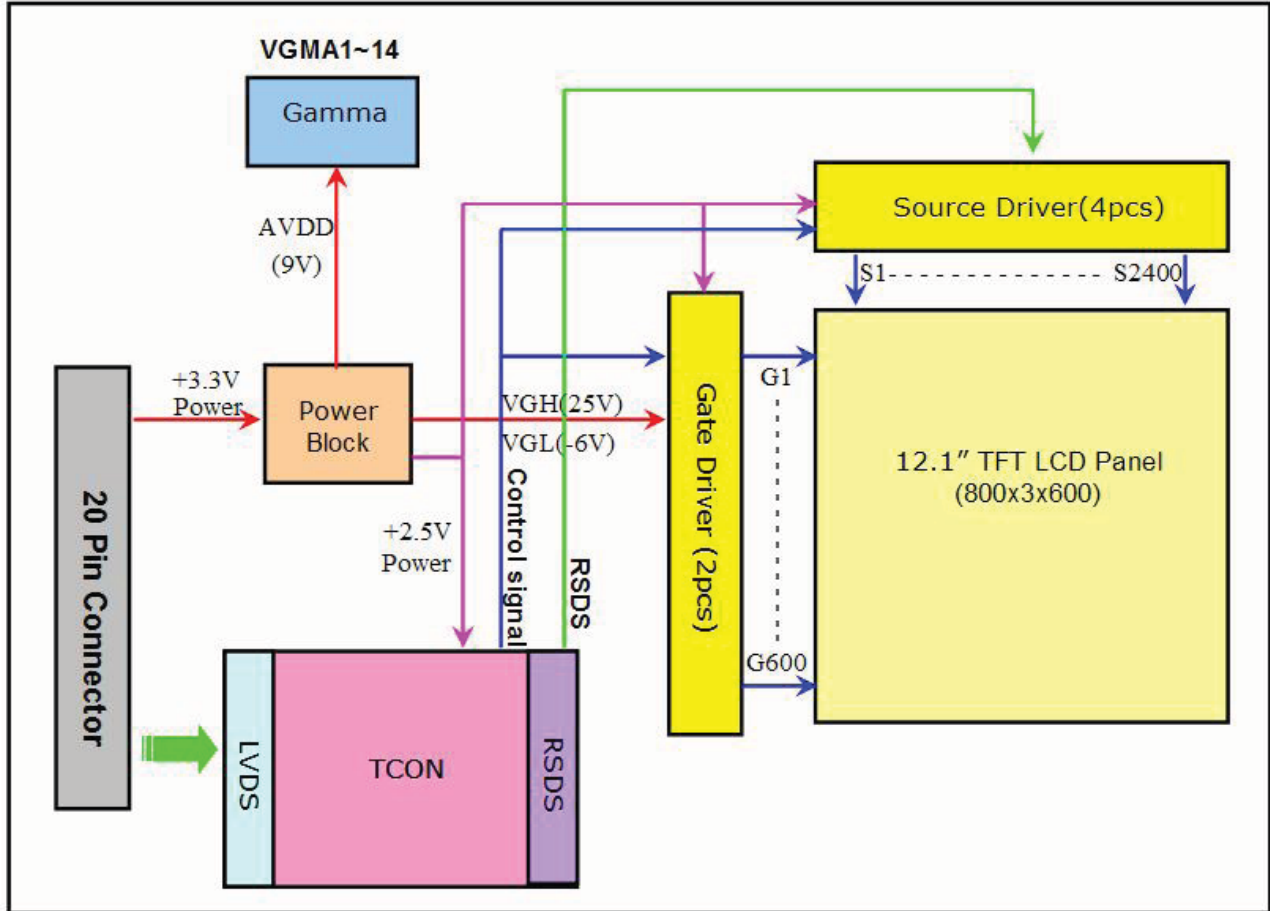

LVDS Connector:

MSB240420-E

Lamp Connector:

JST BHR-03VS-1

Mating Type:

P240420 or compatible

Mating Type:

SM03(4.0)B-BHS-1-TB

CONFIDENTIAL



4. Absolute Maximum Ratings

4.1 Absolute Ratings of TFT LCD Module

Item	Symbol	Min	Max	Unit
Logic/LCD Drive	Vin	-0.3	+3.6	[Volt]

4.2 Absolute Ratings of Environment

Item	Symbol	Min	Max	Unit
Operating Temperature	TOP	-30	+85	[°C]
Operation Humidity	HOP	8	95	[%RH]
Storage Temperature	TST	-30	+85	[°C]
Storage Humidity	HST	5	95	[%RH]

Note: Maximum Wet-Bulb should be 39°C and no condensation.

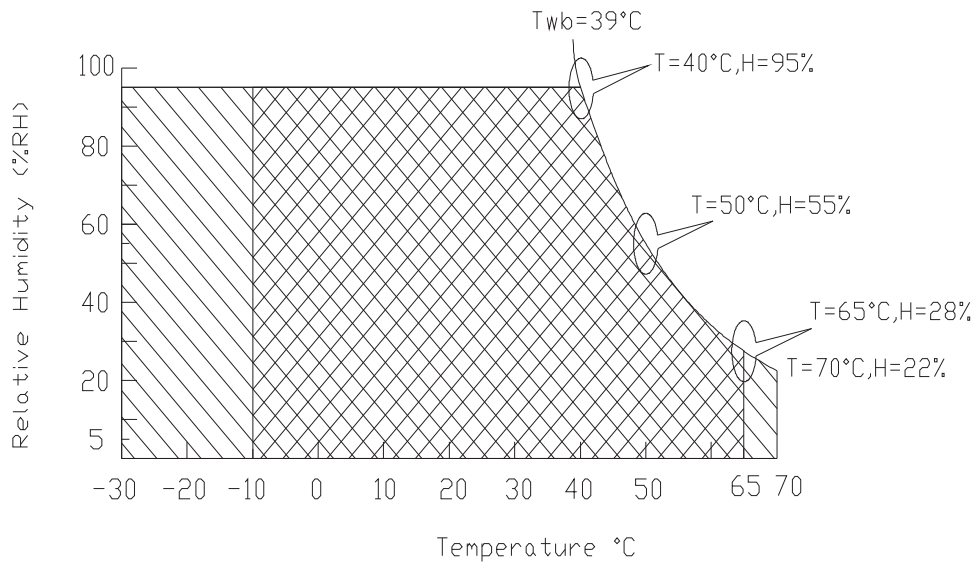

Operating Range

Storage Range +

CONFIDENTIAL



5. Electrical Characteristics

5.1 TFT LCD Module

5.1.1 Power Specification

Symbol	Parameter	Min	Typ	Max	Units	Remark
VDD	Logic/LCD Drive Voltage	3.0	3.3	3.6	[Volt]	
IDD	VDD Current	-	285	325	[mA]	VDD=3.3V, All Black Pattern
Irush	LCD Inrush Current	-	-	1.5	[A]	Vin=3.3V, With Black Pattern, Rising time=500us,
PDD	VDD Power	-	0.94	1.07	[Watt]	VDD=3.3V, All Black Pattern
VDDrp	Allowable Logic/LCD Drive Ripple Voltage	-		100	[mV] p-p	
VDDns	Allowable Logic/LCD Drive Ripple Noise			100	[mV] p-p	

CONFIDENTIAL

5.1.2 Signal Electrical Characteristics

Input signals shall be low or Hi-Z state when VDD is off.

Symbol	Item	Min.	Typ.	Max.	Unit	Remark
VID	Input Differential Voltage	250	350	450	[mV]	
VICM	Differential Input Common Mode Voltage	1.0	1.25	2.0	[V]	
VTH	Differential Input High Threshold	-	-	100	[mV]	VCM=1.25V
VTL	Differential Input Low Threshold	-100	-	-	[mV]	VCM=1.25V
CLK	Clock frequency	30	40	50	MHz	

Note: LVDS Signal Waveform.

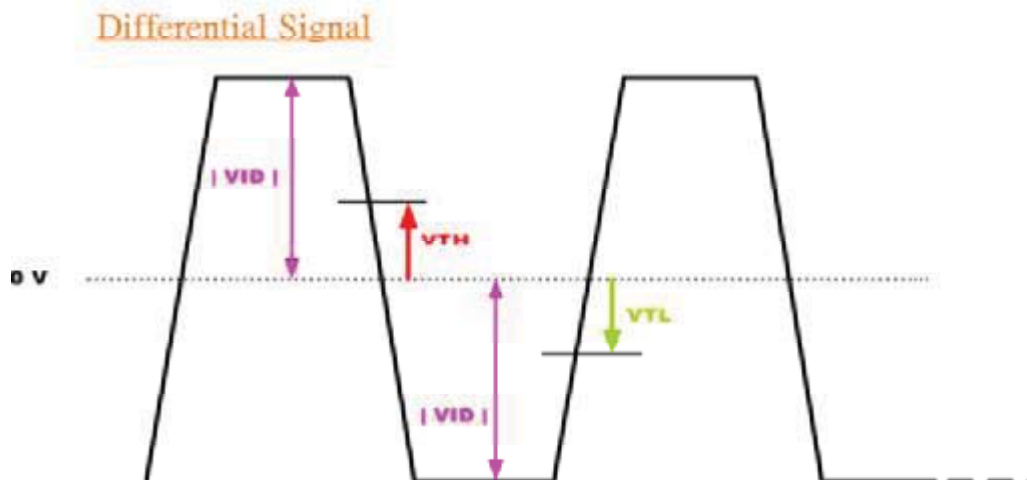
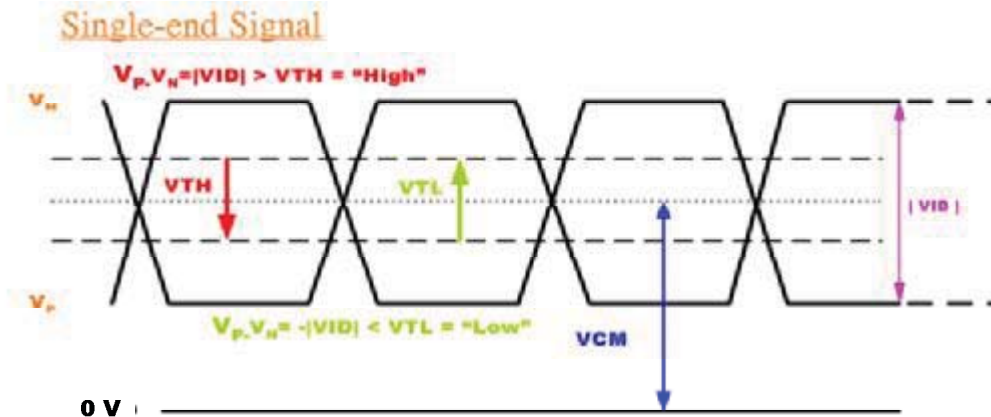

CONFIDENTIAL



5.2 Backlight Unit

5.2.1 Parameter guideline for CCFL

Following characteristics are measured under a stable condition using an inverter at 25 °C (Room Temperature):

Symbol	Parameter	Min.	Typ.	Max.	Unit	Remark
IRCFL	CCFL operation range	3	6	6.5	[mA] rms	(Ta=25°C) Note 1, 2
FCFL	CCFL Frequency	40	55	60	[KHz]	(Ta=25°C) Note 3
V _i CCFL 0°C (reference)	CCFL Ignition Voltage	-	930	1,120	[Volt] rms	(Ta= 0°C)
V _i CCFL (25°C) (reference)	CCFL Ignition Voltage	-	770	930	[Volt] rms	(Ta=25°C)
PCFL	CCFL Power consumption (inverter excluded)	3.8	6.7	7.7	[Watt]	(Ta=25°C) Note 4
Lamp Life		50,000		-	Hrs	(Ta=25°C) Note 2 IRCFL = 6mA

Note 1: IRCFL is defined as the return current of an inverter. (In Figure 1)

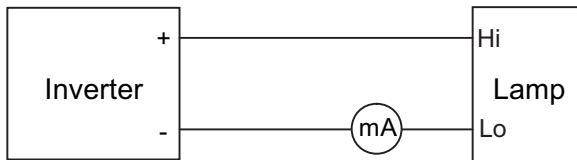

(Figure 1: Measurement of return current)

A stable IRCFL is a current without flicker or biasing waveform provided by inverter that ensures the backlight perform to its specification. The ideal sine waveform should be symmetric in positive and negative polarities and the asymmetry rate of the inverter waveform should be below 10%.

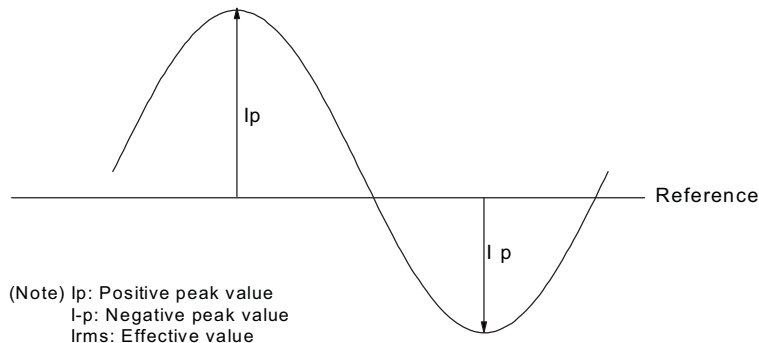

$$\text{DC Bias} = (|I_p - I_p| / I_{rms}) \times 100 \% < 10\%$$

$$\text{Crest Factor} = I_p \text{ or } (I_p) / I_{rms} \text{ should have the range within } 1.414 \pm 10\%$$



It is recommended to use the inverter with detection circuit (ie: balance and protection circuit) to avoid overvoltage, overcurrent, or mismatching waveform.

Note 2: The definition of lamp life means when any of following conditions happen:

- a) Luminance falls to 50% or less of the initial value.
- b) Normal lighting is no more available (flickering, pink lighting, no lighting, etc.)
- c) Lamp voltage or lighting start voltage exceeds the specified value.

Lamp life time shortens according to

- a) Placing methodology: mercury is unevenly distributed in portrait mounting
- b) Environmental condition: low temperature reduces the presence of mercury vapor, which results in approximately lamp life of 1,000 hours
- c) CCFL surface temperature: Presence of gradient in lamp surface temperature causes uneven mercury migration
- d) Inverter design: its resonance capacitor should be fine-tuned with the impedance of CCFL
- e) Over driving current (> 6.5 mA) shortens lamp life time dramatically.

Note 3: CCFL frequency should be carefully determined to avoid interference between inverter and TFT LCD. Higher frequency will induce higher leakage current and further impact lamp life.

Note 4: Calculator value for reference ($IRCFL \times VCFL \times 2 = PCFL$).

Note 5: The display is with dual lamp design, and the CCFL current in above table refers to each lamp

CONFIDENTIAL



6. Signal Characteristic

6.1 Pixel Format Image

Following figure shows the relationship between input signal and LCD pixel format.

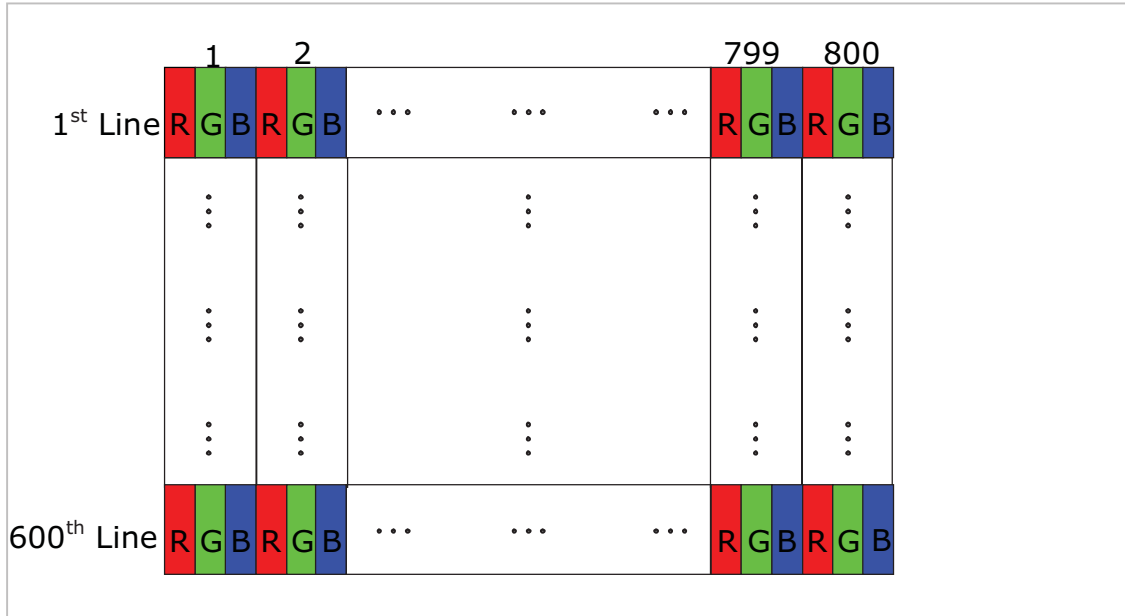

6.2 Scanning Direction

The following figures show the image seen from the front view. The arrow indicates the direction of scan.

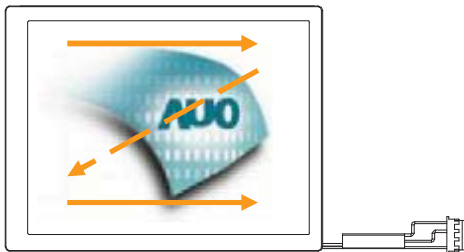

Fig. 1 Normal scan (Pin19 = GND/NC)

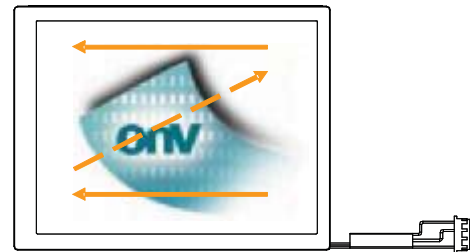

Fig. 2 Reverse scan (Pin19 = High)

CONFIDENTIAL



6.3 Signal Description

The module uses a LVDS receiver embedded in AUO's ASIC. LVDS is a differential signal technology for LCD interface and a high-speed data transfer device. Mating LVDS transmitter: THC63LVDM83A or equivalent device

Pin Assignment:

Pin#	Signal Name	Description
1	VCC	3.3V Power Supply
2	VCC	3.3V Power Supply
3	GND	GND
4	6-8Bit SEL	Select 6 or 8 Bits LVDS Input (VCC:8Bits ; GND/NC: 6Bits)
5	RIN0-	Negative(-) LVDS differential data input
6	RIN0+	Positive(+) LVDS differential data input
7	GND	GND
8	RIN1-	Negative(-) LVDS differential data input
9	RIN1+	Positive(+) LVDS differential data input
10	GND	GND
11	RIN2-	Negative(-) LVDS differential data input
12	RIN2+	Positive(+) LVDS differential data input
13	GND	GND
14	CLKIN-	Clock Signal(-)
15	CLKIN+	Clock Signal(+)
16	GND	GND
17	RIN3-	Negative(-) LVDS differential data input (Used for 8Bits LVDS Input; NC for 6Bits)
18	RIN3+	Positive(+) LVDS differential data input(Used for 8Bits LVDS Input; NC for 6Bits)
19	REVERSE	Display Reversed Function (VCC: Display Reverse; GND/NC: Normal Display)
20	NC/GND	AUO Test Function Pin(Do not set this pin to High)

**Note1 : Pin19 can be used for enabling "reverse scan" function.
Refer to section 6.1 for scanning direction.**

Signal Description:

Signal Name	Description
RxIN0-, RxIN0+	LVDS differential data input (Red0-Red5, Green0)
RxIN1-, RxIN1+	LVDS differential data input (Green1-Green5, Blue0-Blue1)
RxIN2-, RxIN2+	LVDS differential data input (Blue2-Blue5, Hsync, Vsync, DE)
CKIN-, CKIN+	LVDS differential clock input
Reverse	High: Reverse Display; NC/GND: Normal Display
VDD	+3.3V Power Supply
GND	Ground
NC	No Connection

Note: Input signals shall be low or Hi-Z state when VDD is off.

CONFIDENTIAL



LVDS Signal Format:

6/8 SEL = Low (GND)

6bits LVDS input → When FRC='0', IND 3 pair fix to "Low"



6/8 SEL = High

8bits LVDS input → When FRC='1', IND 3 pair active

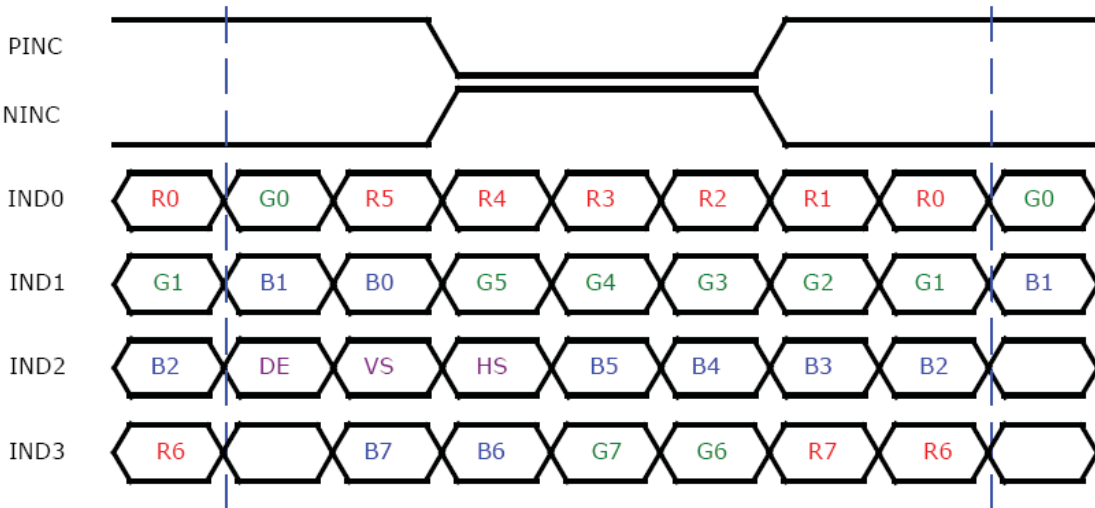

CONFIDENTIAL



6.4 The Input Data Format

Signal Name	Description	
+RED5 +RED4 +RED3 +RED2 +RED1 +RED0	Red Data 5 (MSB) Red Data 4 Red Data 3 Red Data 2 Red Data 1 Red Data 0 (LSB) Red-pixel Data	Red-pixel Data Each red pixel's brightness data consists of these 6 bits pixel data.
+GREEN5 +GREEN4 +GREEN3 +GREEN2 +GREEN1 +GREEN0	Green Data 5 (MSB) Green Data 4 Green Data 3 Green Data 2 Green Data 1 Green Data 0 (LSB) Green-pixel Data	Green-pixel Data Each green pixel's brightness data consists of these 6 bits pixel data.
+BLUE5 +BLUE4 +BLUE3 +BLUE2 +BLUE1 +BLUE0	Blue Data 5 (MSB) Blue Data 4 Blue Data 3 Blue Data 2 Blue Data 1 Blue Data 0 (LSB) Blue-pixel Data	Blue-pixel Data Each blue pixel's brightness data consists of these 6 bits pixel data.
CLK	Data Clock	The typical frequency is 40MHz. The signal is used to strobe the pixel data and DE signals. All pixel data shall be valid at the falling edge when the DE signal is high.
DE	Display Timing	This signal is strobed at the falling edge of CLK. When the signal is high, the pixel data shall be valid to be displayed.
VSYNC	Vertical Sync	The signal is synchronized to CLK.
HSYNC	Horizontal Sync	The signal is synchronized to CLK.

Note: Output signals from any system shall be low or Hi-Z state when VDD is off.

CONFIDENTIAL



6.5 Interface Timing

6.5.1 Timing Characteristics

DE only mode

Parameter	Symbol	Min.	Typ.	Max.	Unit	Condition
Clock frequency	$1/T_{Clock}$	33.6	39.8	48.3	MHz	
Vertical Section	Period	T_V	608	628	650	T_{Line}
	Active	T_{VD}	600	600	600	
	Blanking	T_{VB}	8	28	50	
Horizontal Section	Period	T_H	920	1056	1240	T_{Clock}
	Active	T_{HD}	800	800	800	
	Blanking	T_{HB}	120	256	440	

Note1: Frame rate is 60 Hz.

Note2: Typical value refer to VESA Standard

6.5.2 Input Timing Diagram

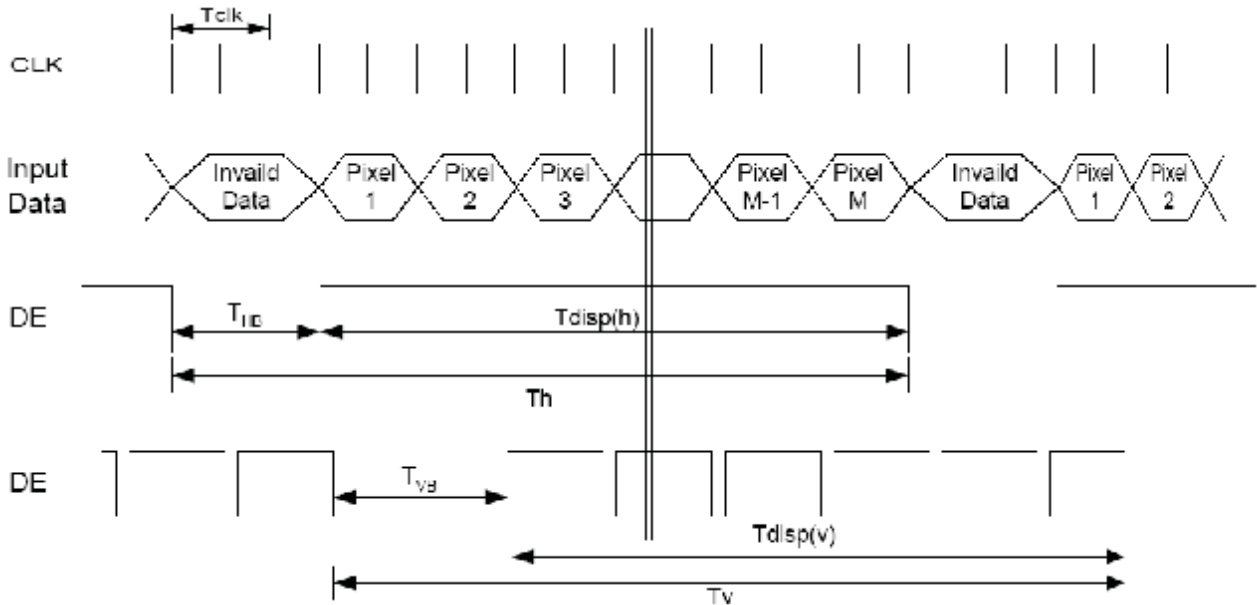

CONFIDENTIAL



6.6 Power ON/OFF Sequence

VDD power and lamp on/off sequence is as below. Interface signals are also shown in the chart. Signals from any system shall be Hi-Z state or low level when VDD is off.

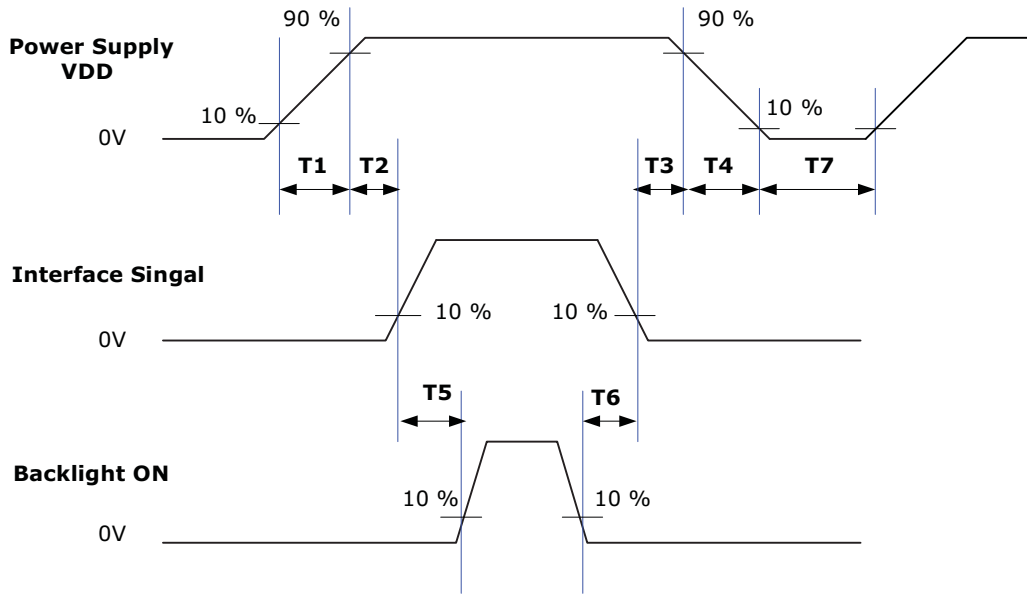

Power ON/OFF sequence timing

Parameter	Value			Units
	Min.	Typ.	Max.	
T1	0.5	-	10	ms
T2	0	-	50	ms
T3	0	-	50	ms
T4	0	-	10	ms
T5	200	-		ms
T6	200	-		ms
T7	500	-	-	Ms

The above on/off sequence should be applied to avoid abnormal function in the display. Please make sure to turn off the power when you plug the cable into the input connector or pull the cable out of the connector.

CONFIDENTIAL



7. Connector & Pin Assignment

Physical interface is described as for the connector on module. These connectors are capable of accommodating the following signals and will be following components.

7.1 TFT LCD Module: LVDS Connector

Connector Name / Designation	Signal Connector
Manufacturer	STM
Connector Model Number	MSB240420-E
Mating Model Number	P240420 or compatible

Mating LVDS transmitter: THC63LVDM83A or equivalent device

7.2 Backlight Unit: Lamp Connector

Connector Name / Designation	Lamp Connector
Manufacturer	JST
Connector Model Number	JST BHR-03VS-1 or compatible
Mating Model Number	JST SM03(4.0)B-BHS-1-TB

Pin no.	Symbol	Function	Remark
1	H	CCFL power supply (H.V.)	Cable color: Pink
2	NC	No connection	
3	L	CCFL power supply (GND)	Cable color: White

CONFIDENTIAL



8. Reliability Test Criteria

Items	Required Condition	Note
High Temperature Operation	85°C, 240Hrs (center point of panel surface)	Note 1, 2, 3
Low Temperature Operation	-30°C, 240Hrs	Note 1, 2, 3
Hot Storage	85°C, 240Hrs	Note 1, 2, 3
Cold Storage	-30°C, 240Hrs	Note 1, 2, 3
High temperature & high humidity operation	50°C, 90%RH, 240Hrs (No condensation)	Note 1, 2, 3
Shock Test (Non-Operating)	50G/11ms, ±X, ±Y, ±Z, half-Sin, one time	Note 1, 2, 3
Vibration Test (Non-Operating)	1.5G, random 10Hz~ 200Hz~ 10Hz 30 minutes for each Axis (X, Y, Z), 15min/Sweep	Note 1, 2, 3
On/off test	On 10sec/OFF 10 sec, 30,000 cycles	Note 1, 2, 3
ESD	Contact Discharge: Max±8KV, 150pF(330Ω) 1sec, 8 points, 25 times/point.	Note 3, 4
	Air Discharge: Max ±15KV, 150pF(330Ω) 1sec, 8 points, 25 times/point	
Thermal shock (non-operation)	1. -20°C±3°C...30minutes 60°C±3°C...30minutes 2. 100 cycles 3. Temperature transition time within 5 minutes	Note 1, 2, 3
Attitude Test	Operation:14,000ft / 8hrs Non-Operation: 40,000ft / 24hrs	Note 3

Note 1: Evaluation should be tested after storage at room temperature for one hour.

Note 2: There should be no change which might affect the practical display function when the display quality test is conducted under normal operating condition.

Note 3: Judgment: 1. Function OK 2. No serious image quality degradation

Note 4: According to EN61000-4-2 , ESD class B: Some performance degradation allowed. No data lost, self-recoverable. No hardware failures.

CONFIDENTIAL



Product Specification

AU OPTRONICS CORPORATION

G121SN01 V3

9. Mechanical Characteristics

9.1 LCM Outline Dimension (Front View)

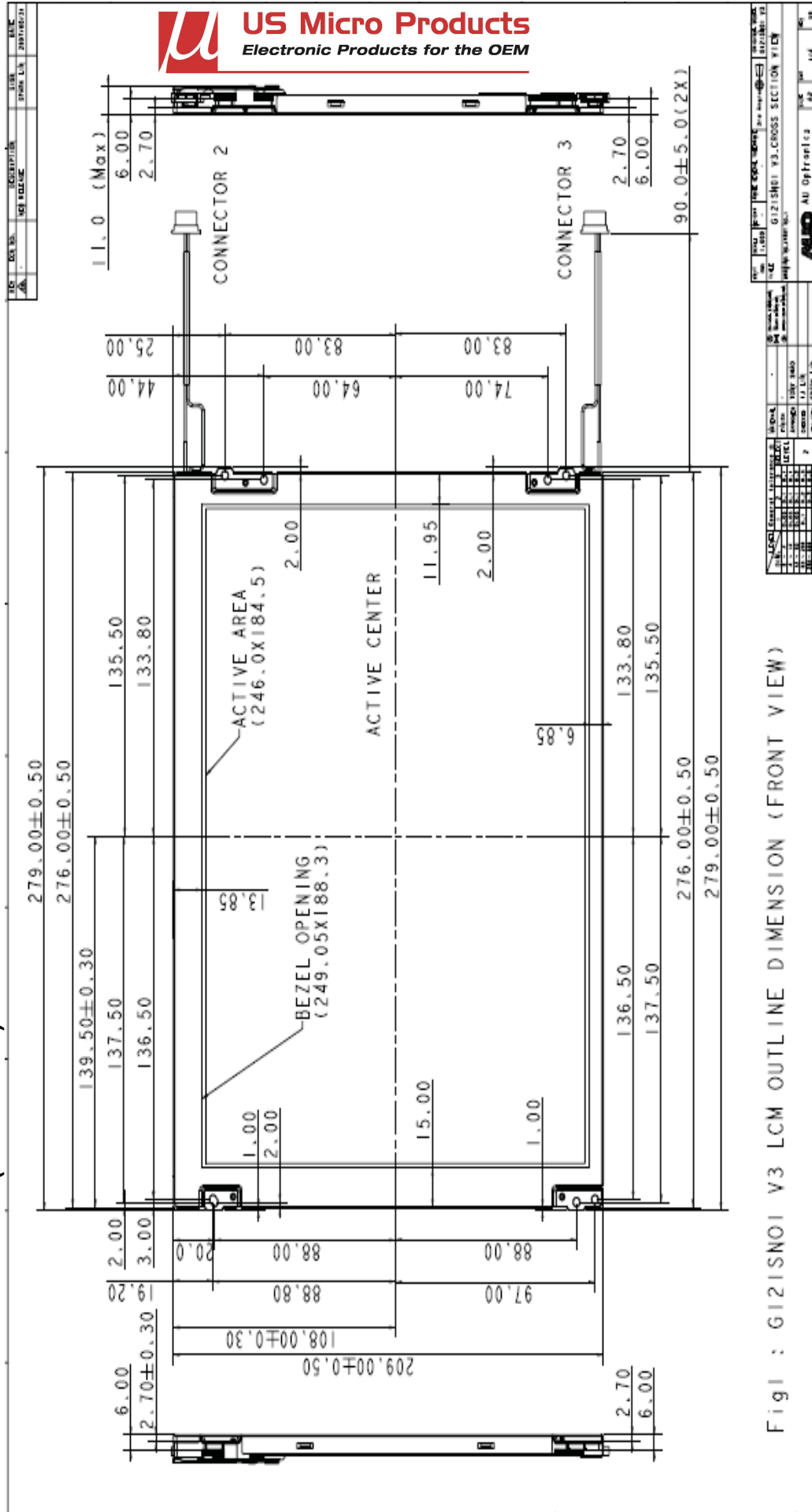
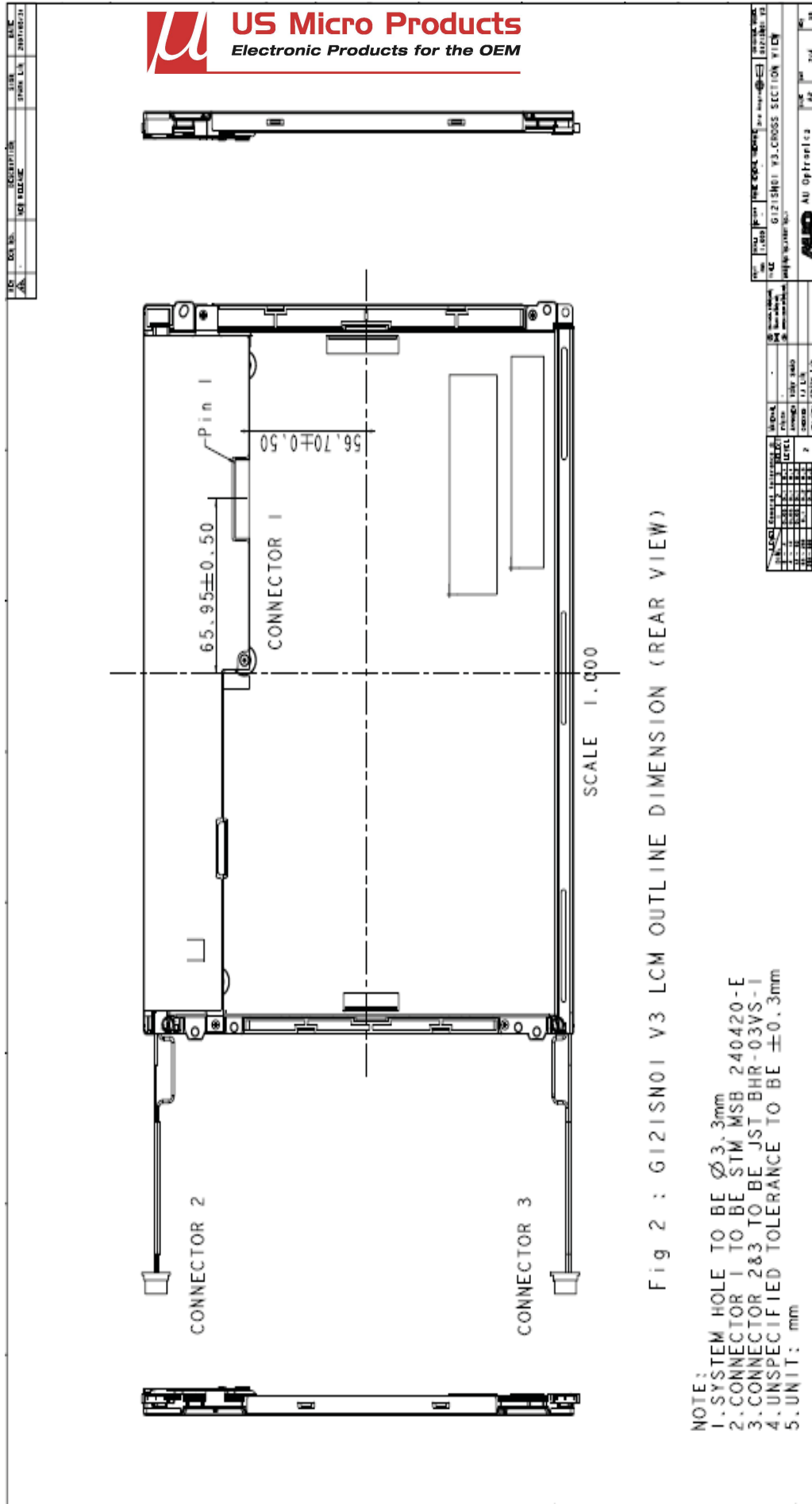

Fig 1 : G121SN01 V3 LCM OUTLINE DIMENSION (FRONT VIEW)

G121SN01 V3 rev.0.0

23/27

9.2 LCM Outline Dimension (Rear View)





9.3 Screw Hole Depth and Center Position

Screw type: M3 screw

Screw hole minimum depth, from side surface =2.7mm (See drawing)

The Max. Diameter of the mounting screw head is 6.0mm

Screw Torque: Maximum 6.0 kgf-cm

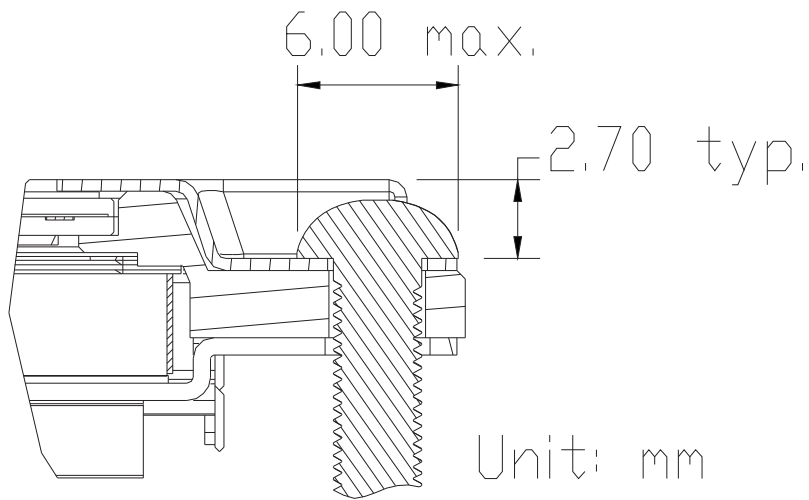

CONFIDENTIAL



10. Label and Packaging

10.1 Shipping Label (on the rear side of TFT-LCD display)

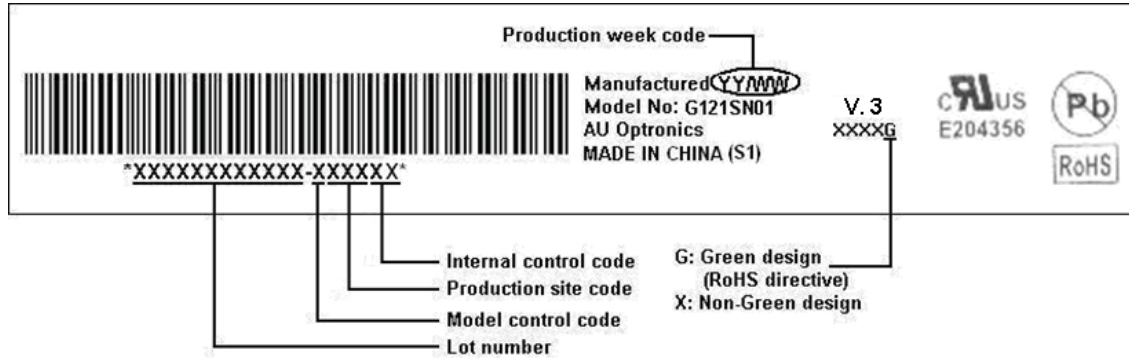

CONFIDENTIAL

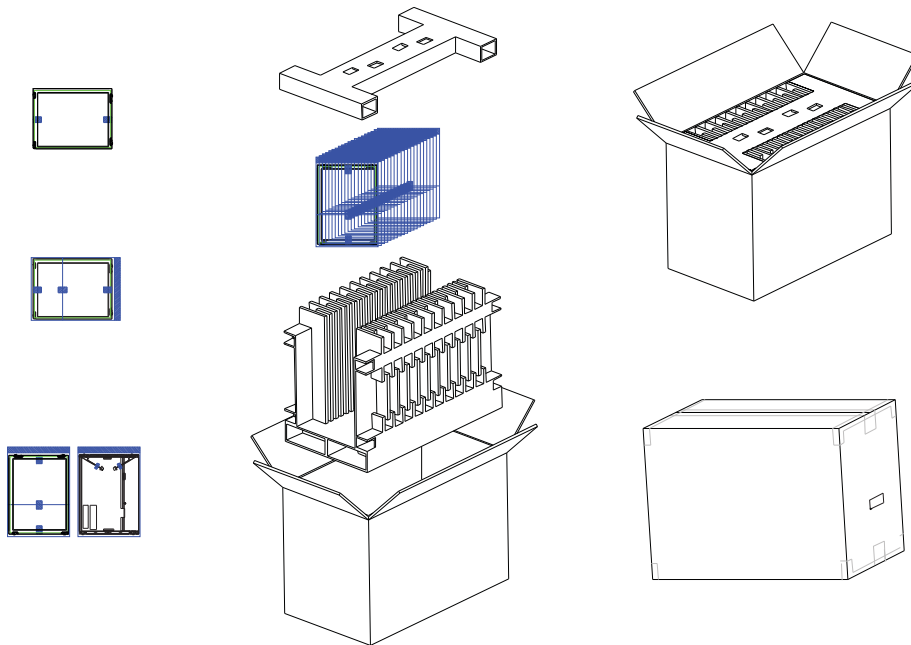



11. Safety

11.1 Sharp Edge Requirements

There will be no sharp edges or comers on the display assembly that could cause injury.

11.2 Materials

Toxicity

There will be no carcinogenic materials used anywhere in the display module. If toxic materials are used, they will be reviewed and approved by the responsible AUO toxicologist.

11.3 Capacitors

If any polarized capacitors are used in the display assembly, provisions will be made to keep them from being inserted backwards.

11.4 National Test Lab Requirement

The display module will satisfy all requirements for compliance to:

UL 60950

U.S.A. Information Technology Equipment

CONFIDENTIAL



US Micro Products

Electronic Products for the OEM

Los Angeles • Austin • New York • Orlando • Shenzhen

(800) 741-7755

www.usmicroproducts.com

Displays

US Micro Products is an industrial distributor specializing in engineered display solutions. We dedicate ourselves to providing the best in displays for the medical, industrial, gaming, automotive, aerospace, military, and consumer markets.

OLEDs



TFT Displays



Open Frame Monitors



Passive LCDs



Multitouch



As a customer, you benefit from our expert knowledge, support and service which allow quick selection and design-in of the best display for your application. On hand stock and demo boards facilitate quick access and evaluation to get you going fast. Our technical sales staff and experienced design engineers provide answers to your questions as well as engineered solutions to solve your display needs.

Peripheral Devices

Our full line of peripheral devices includes keyboards, trackballs, and printers. These rugged industrial products are designed to meet your demanding requirements and are available as both standard and custom solutions.

Keyboards



Trackballs



Aerospace Trackballs



Joysticks



Printers

