



**US Micro Products**  
*Electronic Products for the OEM*

# TFT-LCD PRODUCT SPECIFICATION

Manufactured by



<b>PART NUMBER:</b>	<b>USMP-G104SN02 V1</b>
<b>DESCRIPTION:</b>	10.4" TFT LCD with SVGA (800(H) x 600(V)) screen and 16.2M (RGB 8-bits) or 262k colors (RGB 6-bits).

ISSUE DATE	APPROVED BY (Customer Use Only)	CHECKED BY	PREPARED BY
<b>PROPRIETARY NOTE:</b>	THIS SPECIFICATION IS THE PROPERTY OF US MICRO PRODUCTS AND SHALL NOT BE REPRODUCED OR COPIED WITHOUT THE WRITTEN PERMISSION OF US MICRO PRODUCTS AND MUST BE RETURNED TO US MICRO PRODUCTS UPON ITS REQUEST.		

## Contents

<b>1. Operating Precautions</b> .....	<b>4</b>
<b>2. General Description</b> .....	<b>5</b>
2.1 Display Characteristics .....	5
2.2 Optical Characteristics .....	6
<b>3. Functional Block Diagram</b> .....	<b>9</b>
<b>4. Absolute Maximum Ratings</b> .....	<b>10</b>
4.1 Absolute Ratings of TFT LCD Module.....	10
4.2 Absolute Ratings of Environment .....	10
<b>5. Electrical Characteristics</b> .....	<b>11</b>
5.1 TFT LCD Module.....	11
5.2 Backlight Unit .....	13
<b>6. Signal Characteristic</b> .....	<b>15</b>
6.1 Pixel Format Image .....	15
6.2 Scanning Direction .....	15
6.3 Pin Description .....	16
6.4 The Input Data Format .....	17
6.5 Interface Timing.....	19
6.6 Power ON/OFF Sequence .....	20
<b>7. Connector &amp; Pin Assignment</b> .....	<b>21</b>
7.1 TFT LCD Module: LVDS Connector .....	21
7.2 Backlight Unit: Lamp Connector.....	21
7.3 Lamp Connector Pin Assignment .....	21
<b>9. Mechanical Characteristics</b> .....	<b>23</b>
9.1 LCM Outline Dimension (Front View).....	23
9.2 LCM Outline Dimension (Rear View) .....	24
<b>10. Label and Packaging</b> .....	<b>25</b>
10.1 Shipping Label (on the rear side of TFT-LCD display).....	25
10.2 Carton Package .....	25
<b>11 Safety</b> .....	<b>26</b>
11.1 Sharp Edge Requirements .....	26
11.2 Materials.....	26
11.3 Capacitors .....	26
11.4 National Test Lab Requirement .....	26

CONFIDENTIAL



**Record of Revision**

Version and Date	Page	Old description	New Description
0.0 2007/09/03	All	First Edition	

CONFIDENTIAL

## 1. Operating Precautions

- 1) Since front polarizer is easily damaged, please be cautious and not to scratch it.
- 2) Be sure to turn off power supply when inserting or disconnecting from input connector.
- 3) Wipe off water drop immediately. Long contact with water may cause discoloration or spots.
- 4) When the panel surface is soiled, wipe it with absorbent cotton or soft cloth.
- 5) Since the panel is made of glass, it may be broken or cracked if dropped or bumped on hard surface.
- 6) Since CMOS LSI is used in this module, take care of static electricity and insure human earth when handling.
- 7) Do not open nor modify the module assembly.
- 8) Do not press the reflector sheet at the back of the module to any direction.
- 9) In case if a module has to be put back into the packing container slot after it was taken out from the container, do not press the center of the CCFL Reflector edge. Instead, press at the far ends of the CFL Reflector edge softly. Otherwise the TFT Module may be damaged.
- 10) At the insertion or removal of the Signal Interface Connector, be sure not to rotate nor tilt the Interface Connector of the TFT Module.
- 11) After installation of the TFT Module into an enclosure (Notebook PC Bezel, for example), do not twist nor bend the TFT Module even momentary. At designing the enclosure, it should be taken into consideration that no bending/twisting forces are applied to the TFT Module from outside. Otherwise the TFT Module may be damaged.
- 12) Cold cathode fluorescent lamp in LCD contains a small amount of mercury. Please follow local ordinances or regulations for disposal.
- 13) Small amount of materials having no flammability grade is used in the LCD module. The LCD module should be supplied by power complied with requirements of Limited Power Source (IEC60950 or UL1950), or be applied exemption.
- 14) The LCD module is designed so that the CFL in it is supplied by Limited Current Circuit (IEC60950 or UL1950). Do not connect the CFL in Hazardous Voltage Circuit.
- 15) Severe temperature condition may result in different luminance, response time and lamp ignition voltage.
- 16) Continuous operating TFT-LCD display under low temperature environment may accelerate lamp exhaustion and reduce luminance dramatically.
- 17) The data on this specification sheet is applicable when LCD module is placed in landscape position.
- 18) Continuous displaying fixed pattern may induce image sticking. It's recommended to use screen saver or shuffle content periodically if fixed pattern is displayed on the screen.

## 2. General Description

G104SN02 V1 is a Color Active Matrix Liquid Crystal Display composed of a TFT-LCD display, a driver circuit, and a backlight system. The screen format is intended to support SVGA (800(H) x 600(V)) screen and 16.2M (RGB 8-bits) or 262k colors (RGB 6-bits). All input signals are LVDS interface compatible. Inverter card of backlight is not included.

G104SN02 V1 is designed for industrial display applications.

### 2.1 Display Characteristics

The following items are characteristics summary on the table under 25 °C condition:

Items	Unit	Specifications
Screen Diagonal	[inch]	10.4
Active Area	[mm]	211.2 (H) x 158.4 (V)
Pixels H x V		800 x 3(RGB) x 600
Pixel Pitch	[mm]	0.264 x 0.264
Pixel Arrangement		R.G.B. Vertical Stripe
Display Mode		TN, Normally White
Nominal Input Voltage VDD	[Volt]	3.3 (typ.)
Typical Power Consumption	[Watt]	6.5W (IRCFL=6mA, Black pattern)
Weight	[Grams]	495 (typ.)
Physical Size	[mm]	243.0(H) x 184.0(V) x 10.6(D) (typ.)
Electrical Interface		1 channel LVDS
Surface Treatment		Anti-glare, Hardness 3H
Support Color		16.2M / 262K colors
Temperature Range Operating Storage (Non-Operating)	[°C] [°C]	-30 to +85 -30 to +85
RoHS Compliance		RoHS Compliance

CONFIDENTIAL

## 2.2 Optical Characteristics

The optical characteristics are measured under stable conditions at 25°C (Room Temperature):

Item	Unit	Conditions	Min.	Typ.	Max.	Note
White Luminance	[cd/m <sup>2</sup> ]	IRCFL= 6mA (center point)	320	400	-	1
Uniformity	%	5 Points	65	75	-	2, 3
Contrast Ratio			400	500	-	4
Response Time	[msec]	Rising	-	10	20	5
	[msec]	Falling	-	20	30	
	[msec]	Raising + Falling	-	30	50	
Viewing Angle	[degree]	Horizontal (Right) CR = 10 (Left)	60	70	-	6
	[degree]		60	70	-	
	[degree]	Vertical (Upper) CR = 10 (Lower)	45	55	-	
			55	65	-	
Color / Chromaticity Coordinates (CIE 1931)		Red x	0.54	0.57	0.60	
		Red y	0.29	0.32	0.35	
		Green x	0.29	0.32	0.35	
		Green y	0.53	0.56	0.59	
		Blue x	0.13	0.16	0.19	
		Blue y	0.12	0.15	0.18	
		White x	0.29	0.32	0.35	
		White y	0.30	0.33	0.36	
Color Gamut	%			45	-	

Note 1: Measurement method

Equipment Pattern Generator, Power Supply, Digital Voltmeter, Luminance meter (SR\_3 or equivalent)

Aperture 1° with 50cm viewing distance

Test Point Center

Environment < 1 lux

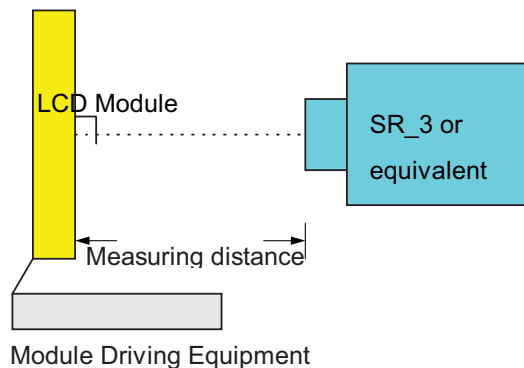

CONFIDENTIAL

Note 2: Definition of 5 points position (Display active area: 211.2mm (H) x 158.4mm (V))

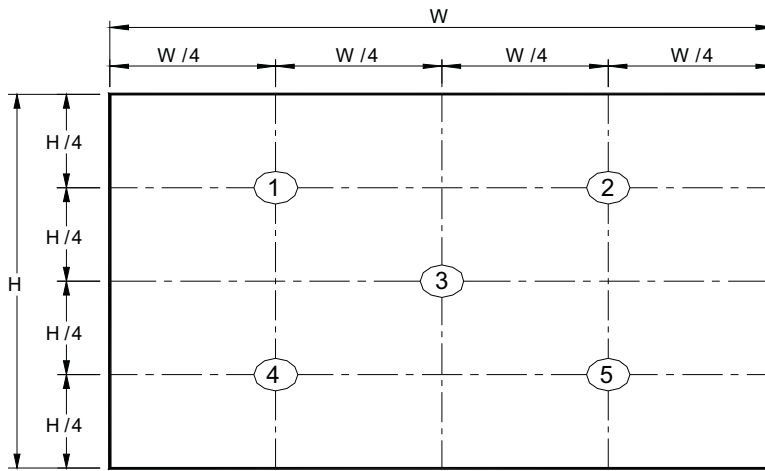

Note 3: The luminance uniformity of 5 points is defined by dividing the minimum luminance values by the maximum test point luminance

$$\delta_{w9} = \frac{\text{Minimum Brightness of five points}}{\text{Maximum Brightness of five points}}$$

Note 4: Definition of contrast ratio (CR):

$$\text{Contrast ratio (CR)} = \frac{\text{Brightness on the "White" state}}{\text{Brightness on the "Black" state}}$$

CONFIDENTIAL

Note 5: Definition of response time:

The output signals of photo detector are measured when the input signals are changed from “White” to “Black” (falling time) and from “Black” to “White” (rising time), respectively. The response time interval is between 10% and 90% of amplitudes. Please refer to the figure as below.

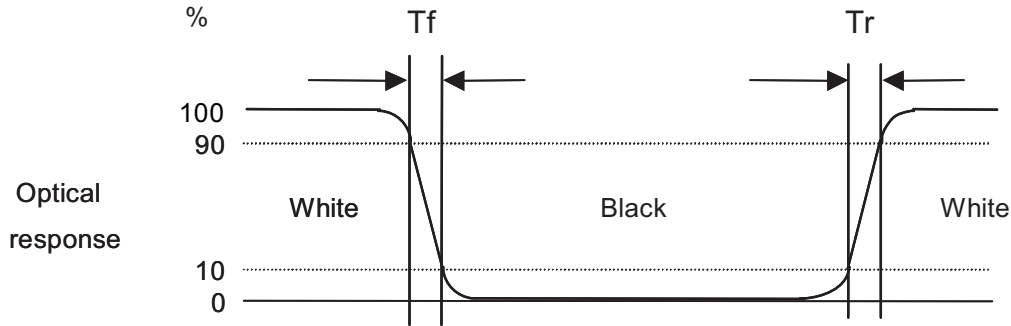

Note 6: Definition of viewing angle

Viewing angle is the measurement of contrast ratio  $\geq 10$ , at the screen center, over a 180° horizontal and 180° vertical range (off-normal viewing angles). The 180° viewing angle range is broken down as below: 90° ( $\theta$ ) horizontal left and right, and 90° ( $\Phi$ ) vertical high (up) and low (down). The measurement direction is typically perpendicular to the display surface with the screen rotated to its center to develop the desired measurement viewing angle.

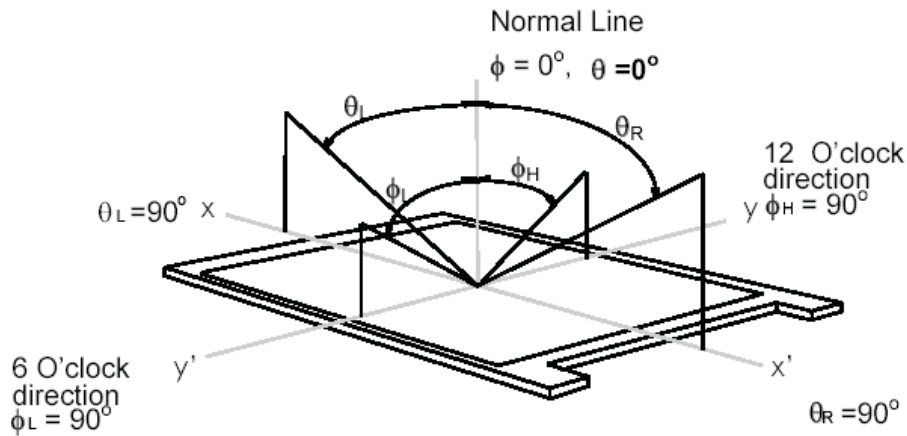

CONFIDENTIAL



### 3. Functional Block Diagram

The following diagram shows the functional block of the 10.4 inch color TFT/LCD module:

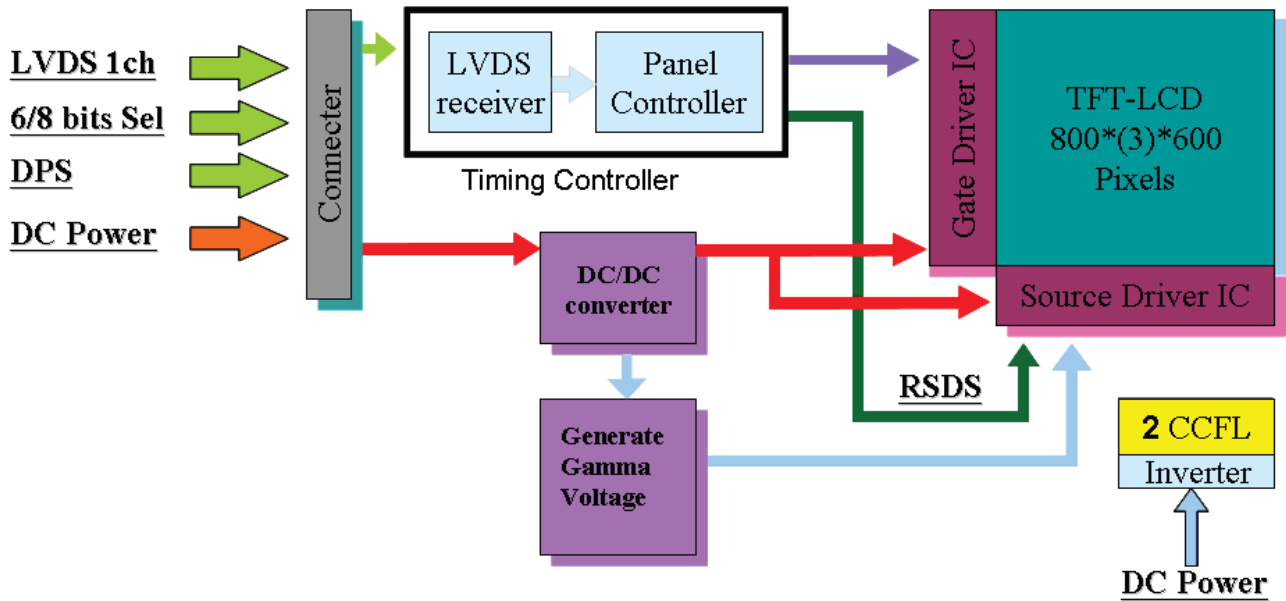

CONFIDENTIAL

## 4. Absolute Maximum Ratings

### 4.1 Absolute Ratings of TFT LCD Module

Item	Symbol	Min	Max	Unit
Logic/LCD Drive	Vin	-0.3	+4.0	[Volt]

### 4.2 Absolute Ratings of Environment

Item	Symbol	Min	Max	Unit
Operating Temperature	TOP	-30	+85	[°C]
Operation Humidity	HOP	5	95	[%RH]
Storage Temperature	TST	-30	+85	[°C]
Storage Humidity	HST	5	95	[%RH]

Note: Maximum Wet-Bulb should be 39°C and no condensation.

CONFIDENTIAL

## 5. Electrical Characteristics

### 5.1 TFT LCD Module

#### 5.1.1 Power Specification

Symbol	Parameter	Min	Typ	Max	Units	Remark
VDD	Logic/LCD Drive Voltage	3.0	3.3	3.6	[Volt]	
IDD	VDD Current		240		[mA]	VDD=3.3V, Black Pattern
PDD	VDD Power		0.8		[Watt]	VDD=3.3V, Black Pattern
Irush	LCD Inrush Current			1.5	[A]	Note 1; VDD=3.3V Black Pattern, Rising time=470us
VDDrp	Allowable Logic/LCD Drive Ripple Voltage			100	[mV] p-p	VDD=3.3V, Black Pattern

Note 1: Measurement condition:

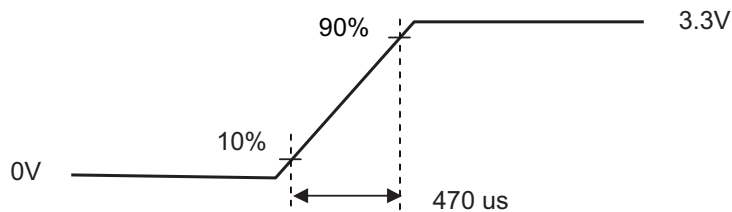
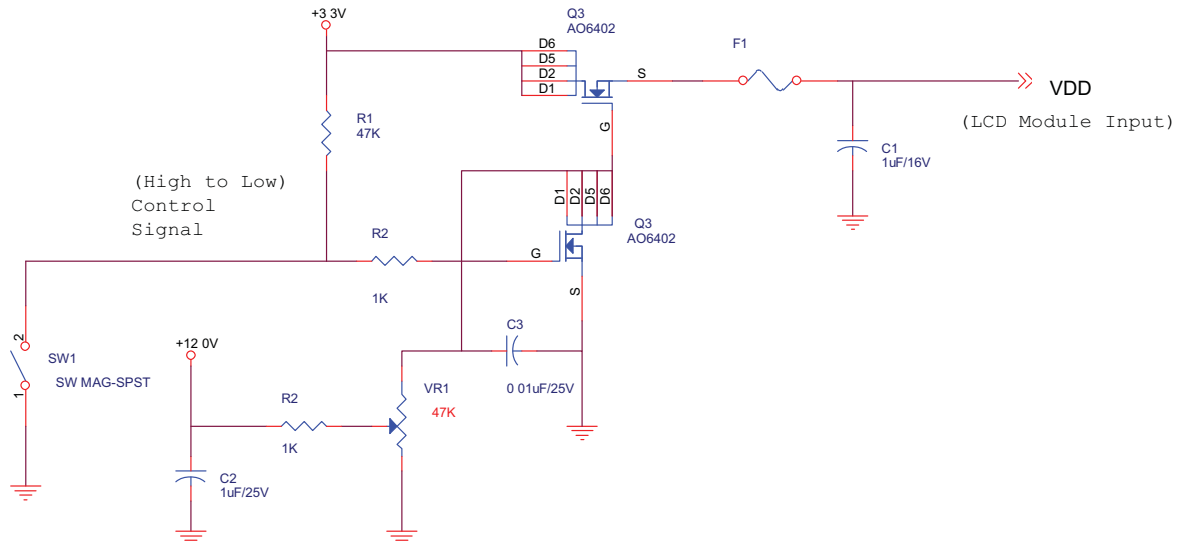

VDD rising time

CONFIDENTIAL

### 5.1.2 Signal Electrical Characteristics

Input signals shall be low or Hi-Z state when VDD is off.

Symbol	Item	Min.	Typ.	Max.	Unit	Remark
VTH	Differential Input High Threshold			100	[mV]	VCM=1.2V
VTL	Differential Input Low Threshold	100			[mV]	VCM=1.2V
VID	Input Differential Voltage	100	400	600	[mV]	
VICM	Differential Input Common Mode Voltage	1.1		1.45	[V]	VTH/VTL=+-100mV

Note: LVDS Signal Waveform.

#### Single-end Signal

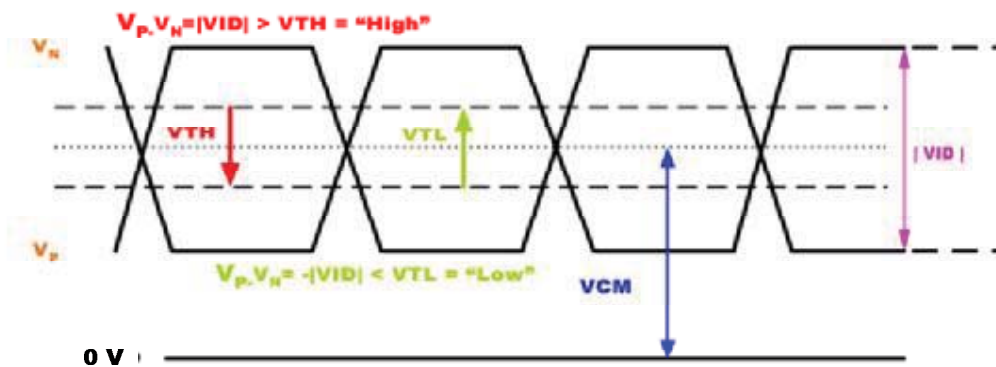

#### Differential Signal

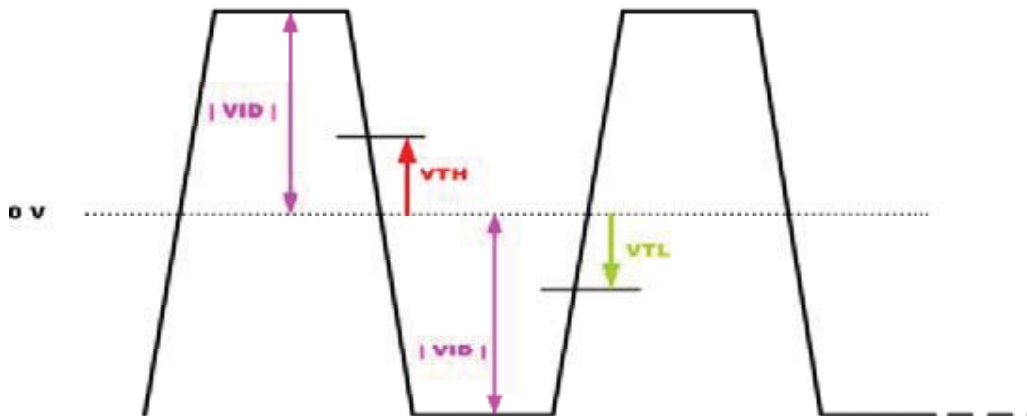

CONFIDENTIAL

## 5.2 Backlight Unit

### 5.2.1 Parameter guideline for CCFL

Following characteristics are measured under a stable condition using an inverter at 25°C (Room Temperature):

Symbol	Parameter	Min.	Typ.	Max.	Unit	Remark
IRCFL	CCFL operation range		6.0	6.5	[mA] rms	(Ta=25°C) Note 1
FCFL	CCFL Frequency	40		60	[KHz]	(Ta=25°C) Note 2
V <sub>i</sub> CCFL (0°C) (reference)	CCFL Ignition Voltage			1160	[Volt] rms	(Ta= 0°C)
V <sub>i</sub> CCFL (25°C) (reference)	CCFL Ignition Voltage			890	[Volt] rms	(Ta=25°C)
VCFL	CCFL Discharge Voltage	423	470	517	[Volt] rms	(Ta=25°C) Note 3 IRCFL=6 mA VCFL = Typ±10%
PCFL	CCFL Power Consumption (inverter excluded)		5.64		[Watt]	(Ta=25°C) Note 3 IRCFL=6 mA
Lamp Life		50,000	-		Hrs	(Ta=25°C) Note 4 IRCFL = 6 mA

Note 1: IRCFL is defined as the return current of an inverter. (In Figure. 1)

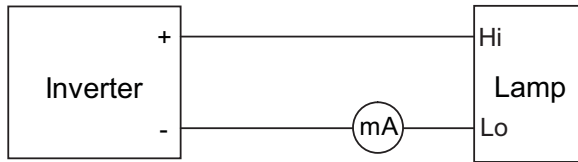

(Figure. 1: Measurement of return current)

A stable IRCFL is a current without flicker or biasing waveform provided by inverter that ensures the backlight perform to its specification. The ideal sine waveform should be symmetric in positive and negative polarities and the asymmetry rate of the inverter waveform should be below 10%.

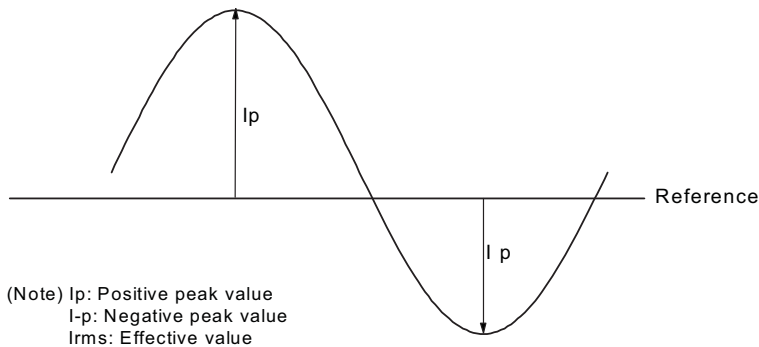

CONFIDENTIAL

DC Bias =  $(|I_p| - |I_p|) / I_{rms} \times 100\% < 10\%$

Crest Factor =  $I_p$  or  $(I_p) / I_{rms}$  should have the range within 1.414<sub>+10%</sub>

It is recommended to use the inverter with detection circuit (ie: balance and protection circuit) to avoid overvoltage, overcurrent, or mismatching waveform.

Note 2: CCFL frequency should be carefully determined to avoid interference between inverter and TFT LCD.

Higher frequency will induce higher leakage current and further impact lamp life.

Note 3: Calculator value for reference ( $IRCFL \times VCFL \times 2 = PCFL$ ).

Note 4: The definition of lamp life means when any of following conditions happen:

- a) Luminance falls to 50% or less of the initial value.
- b) Normal lighting is no more available (flickering, pink lighting, no lighting, etc.)
- c) Lamp voltage or lighting start voltage exceeds the specified value.

Lamp life time shortens according to

- d) Placing methodology: mercury is unevenly distributed in portrait mounting
- e) Environmental condition: low temperature reduces the presence of mercury vapor, which results in approximately lamp life of 1,000 hours
- f) CCFL surface temperature: Presence of gradient in lamp surface temperature causes uneven mercury migration
- g) Inverter design: its resonance capacitor should be fine-tuned with the impedance of CCFL
- h) Over driving current ( $> 6.5 \text{ mA}$ ) shortens lamp life time dramatically.

Note 5: The display is with dual lamp design, and the CCFL current in above table refers to each lamp

CONFIDENTIAL

## 6. Signal Characteristic

### 6.1 Pixel Format Image

Following figure shows the relationship between input signal and LCD pixel format.

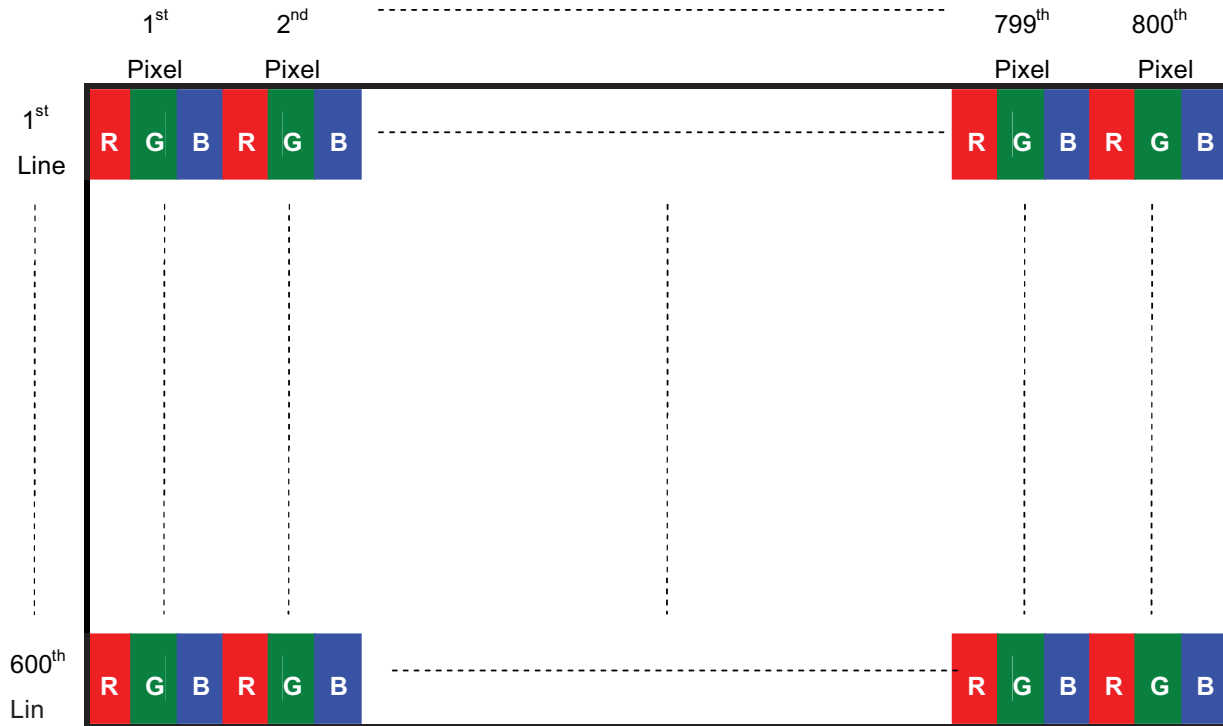

CONFIDENTIAL

### 6.2 Scanning Direction

The following figures show the image seen from the front view. The arrow indicates the direction of scan.

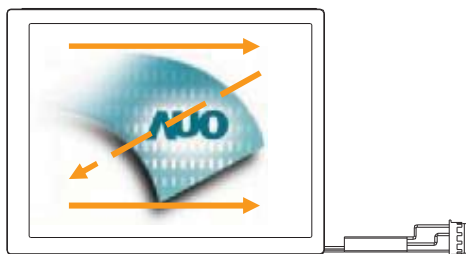

Fig. 1 Normal scan (Pin4, DPS = Low or NC)

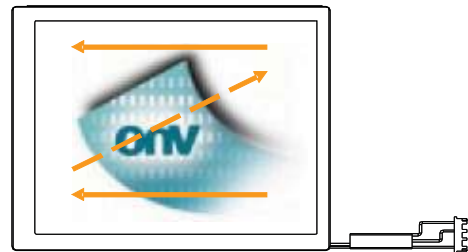

Fig. 2 Reverse scan (Pin4, DPS = High)

### 6.3 Pin Description

The module using a LVDS receiver embaded in AUO's ASIC. LVDS is a differential signal technology for LCD interface and a high-speed data transfer device.

Input Signal Interface		
Pin No.	Symbol	Description
1	VDD	Power Supply, 3.3V (typical)
2	VDD	Power Supply, 3.3V (typical)
3	GND	Ground
4	DPS	Reverse Scan Function [H: Enable; L/NC: Disable]
5	RxIN0-	LVDS receiver signal channel 0
6	RxIN0+	LVDS Differential Data Input (R0, R1, R2, R3, R4, R5, G0)
7	GND	Ground
8	RxIN1-	LVDS receiver signal channel 1
9	RxIN1+	LVDS Differential Data Input (G1, G2, G3, G4, G5, B0, B1)
10	GND	Ground
11	RxIN2-	LVDS receiver signal channel 2
12	RxIN2+	LVDS Differential Data Input (B2, B3, B4, B5, HS, VS, DE)
13	GND	Ground
14	RxCLKIN-	LVDS receiver signal clock
15	RxCLKIN+	
16	GND	Ground
17	RxIN3-	LVDS receiver signal channel 3, NC for 6 bit LVDS Input
18	RxIN3+	LVDS Differential Data Input (R6, R7, G6, G7, B6, B7, RSV)
19	RSV	Reserved for AUO internal test. Please treat it as NC.
20	SEL68	6/ 8bits LVDS data input selection [H: 8bits L/NC: 6bit]

- Note:
1. Input Signals shall be in low status when VDD is off.
  2. NC means "No Connection".
  3. RSV means "Reserved".

CONFIDENTIAL



## 6.4 The Input Data Format

### 6.4.1 SEL68

SEL68 = “Low” or “NC” for 6 bits LVDS Input

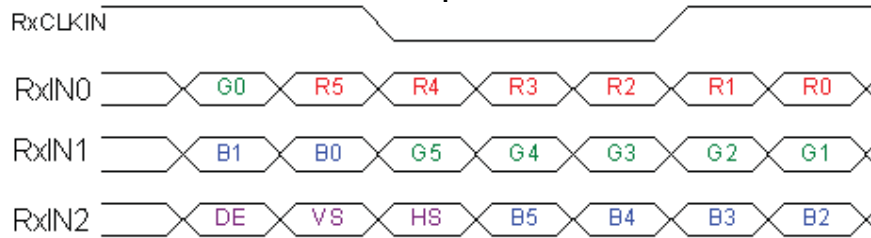

SEL68 = “High” for 8 bits LVDS Input

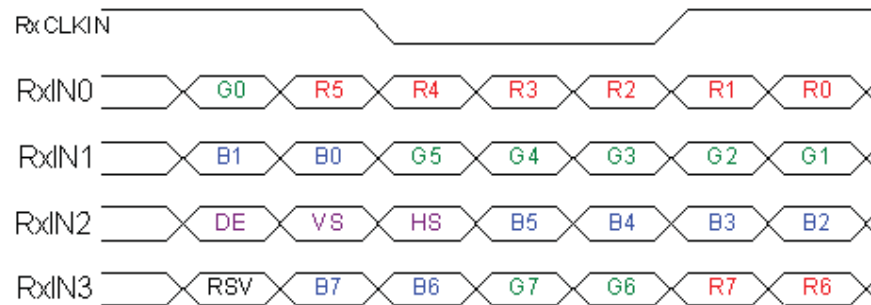

**Note1:** Please follow PSWG.

**Note2:** R/G/B data 7:MSB, R/G/B data 0:LSB

Signal Name	Description	Remark
R7	Red Data 7	Red-pixel Data
R6	Red Data 6	
R5	Red Data 5	
R4	Red Data 4	
R3	Red Data 3	
R2	Red Data 2	
R1	Red Data 1	
R0	Red Data 0	
G7	Green Data 7	Green-pixel Data
G6	Green Data 6	
G5	Green Data 5	
G4	Green Data 4	
G3	Green Data 3	
G2	Green Data 2	
G1	Green Data 1	
G0	Green Data 0	
B7	Blue Data 7	Blue-pixel Data
B6	Blue Data 6	
B5	Blue Data 5	
B4	Blue Data 4	
B3	Blue Data 3	
B2	Blue Data 2	
B1	Blue Data 1	
B0	Blue Data 0	
RxCLKIN	LVDS Data Clock	
DE	Data Enable Signal	When the signal is high, the pixel data shall be valid to be displayed.
VS	Vertical Synchronous Signal	
HS	Horizontal Synchronous Signal	

CONFIDENTIAL

Note: Output signals from any system shall be low or Hi-Z state when VDD is off.

CONFIDENTIAL

## 6.5 Interface Timing

### 6.5.1 Timing Characteristics

Signal	Parameter	Symbol	Min.	Typ.	Max.	Unit	
Clock Timing	Clock Frequency	$1/T_{Clock}$	30	40	50	MHz	
Vsync Timing	Vertical Section	Period	$T_V$	608	628	1024	$T_{Line}$
		Active	$T_{VD}$	--	600	--	
		Blanking	$T_{VB}$	8	28	424	
Hsync Timing	Horizontal Section	Period	$T_H$	960	1056	1060	$T_{Clock}$
		Active	$T_{HD}$	--	800	--	
		Blanking	$T_{HB}$	160	256	260	

Note: Frame rate is 60 Hz.

Note: DE mode.

Note : Typical value refer to VESA STANDARD

### 6.5.2 Input Timing Diagram

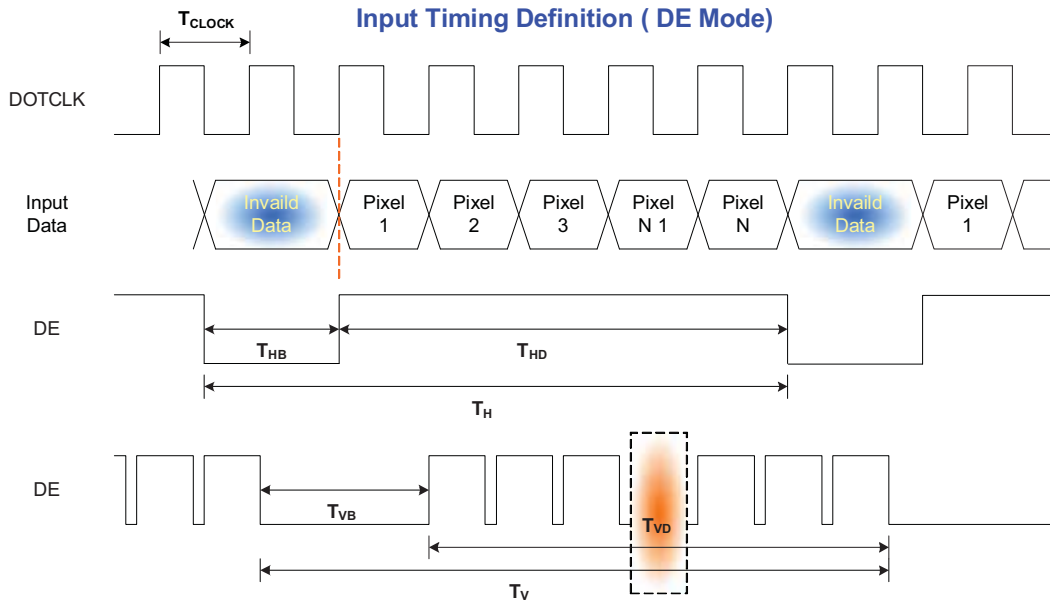

CONFIDENTIAL

## 6.6 Power ON/OFF Sequence

VDD power and lamp on/off sequence is as below. Interface signals are also shown in the chart. Signals from any system shall be Hi-Z state or low level when VDD is off.

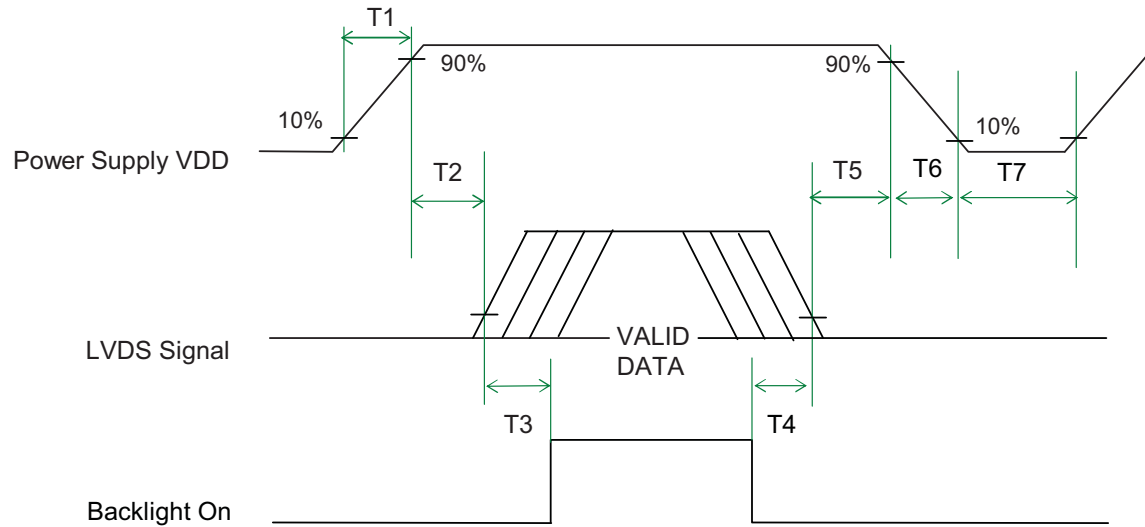

**Power ON/OFF sequence timing**

Parameter	Value			Units
	Min.	Typ.	Max.	
T1	0.5	-	10	ms
T2	0	-	50	ms
T3	180	-		ms
T4	180	-		ms
T5	0	-	50	ms
T6	0	-	10	ms
T7	500	-	-	ms

The above on/off sequence should be applied to avoid abnormal function in the display. Please make sure to turn off the power when you plug the cable into the input connector or pull the cable out of the connector.

CONFIDENTIAL

## 7. Connector & Pin Assignment

Physical interface is described as for the connector on module. These connectors are capable of accommodating the following signals and will be following components.

### 7.1 TFT LCD Module: LVDS Connector

Connector Name / Designation	Signal Connector
Manufacturer	STM or compatible
Connector Model Number	MSB24013P20A or compatible
Adaptable Plug	P24013P20 or compatible

### 7.2 Backlight Unit: Lamp Connector

Connector Name / Designation	Lamp Connector
Manufacturer	JST or compatible
Connector Model Number	BHR-03VS-1 or compatible
Mating Model Number	BHMR-03V or compatible

### 7.3 Lamp Connector Pin Assignment

Pin#	Symbol	Cable color	Signal Name
1	LV	White	Lamp Low Voltage
2	HV	Blue	Lamp High Voltage
3	HV	Pink	Lamp High Voltage

Cable length: 60 ± 5 mm

Connector-output position: right side (front view)

Lamp assembly design shall be easy for replacement and repair

CONFIDENTIAL

## 8. Reliability Test Criteria

Items	Required Condition	Note
Temperature Humidity Bias	40°C / 90%, 300 hours	
High Temperature Operation	85°C, 300 hours	
Low Temperature Operation	-30°C, 300 hours	
Hot Storage	85°C, 300 hours	
Cold Storage	-30°C, 300 hours	
Thermal Shock Test	-20°C / 30 min, 60°C / 30 min, 100cycles, 40°C minimum ramp rate	
Hot Start Test	85°C / 1Hr min. power on/off per 5 minutes, 5 times	
Cold Start Test	-30°C / 1Hr min. power on/off per 5 minutes, 5 times	
Shock Test (Non-Operating)	50G, 20ms, Half-sine wave, ( ±X, ±Y, ±Z)	
Vibration Test (Non-Operating)	1.5G, (10~200Hz, Sine wave) 30 mins/axis, 3 direction (X, Y, Z)	
On/off test	On/10 sec, Off/10 sec, 30,000 cycles	
ESD	Contact Discharge: ± 8KV, 150pF(330Ω ) 1sec, 8 points, 25 times/ point Air Discharge: ± 15KV, 150pF(330Ω ) 1sec, 8 points, 25 times/ point	Note 1
EMI	30-230 MHz, limit 40 dBu V/m, 230-1000 MHz, limit 47 dBu V/m	

Note1: According to EN61000-4-2, ESD class B: Some performance degradation allowed. No data lost  
Self-recoverable. No hardware failures.

CONFIDENTIAL



G104SN02 V1

### 9. Mechanical Characteristics

#### 9.1 LCM Outline Dimension (Front View)

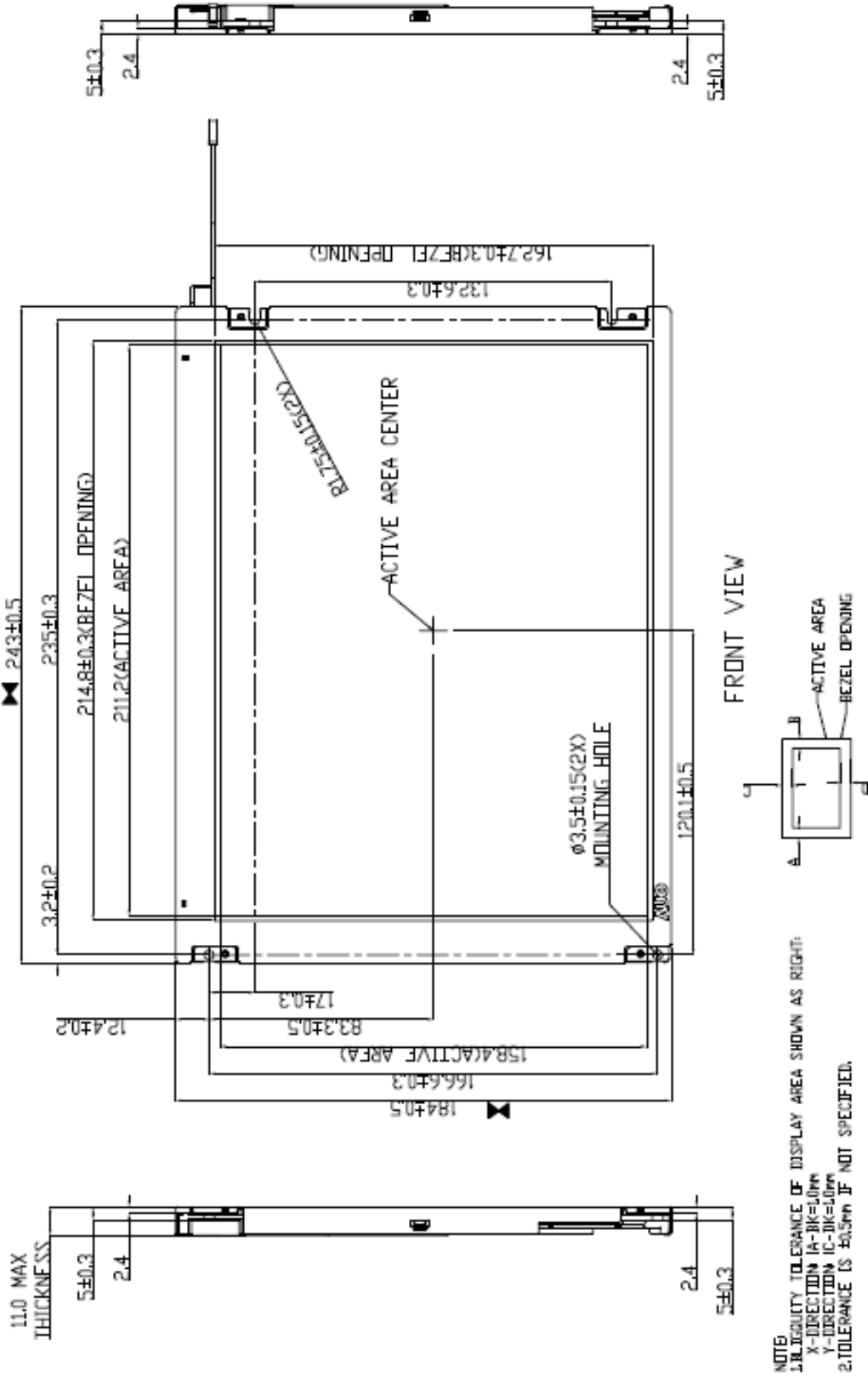



9.2 LCM Outline Dimension (Rear View)

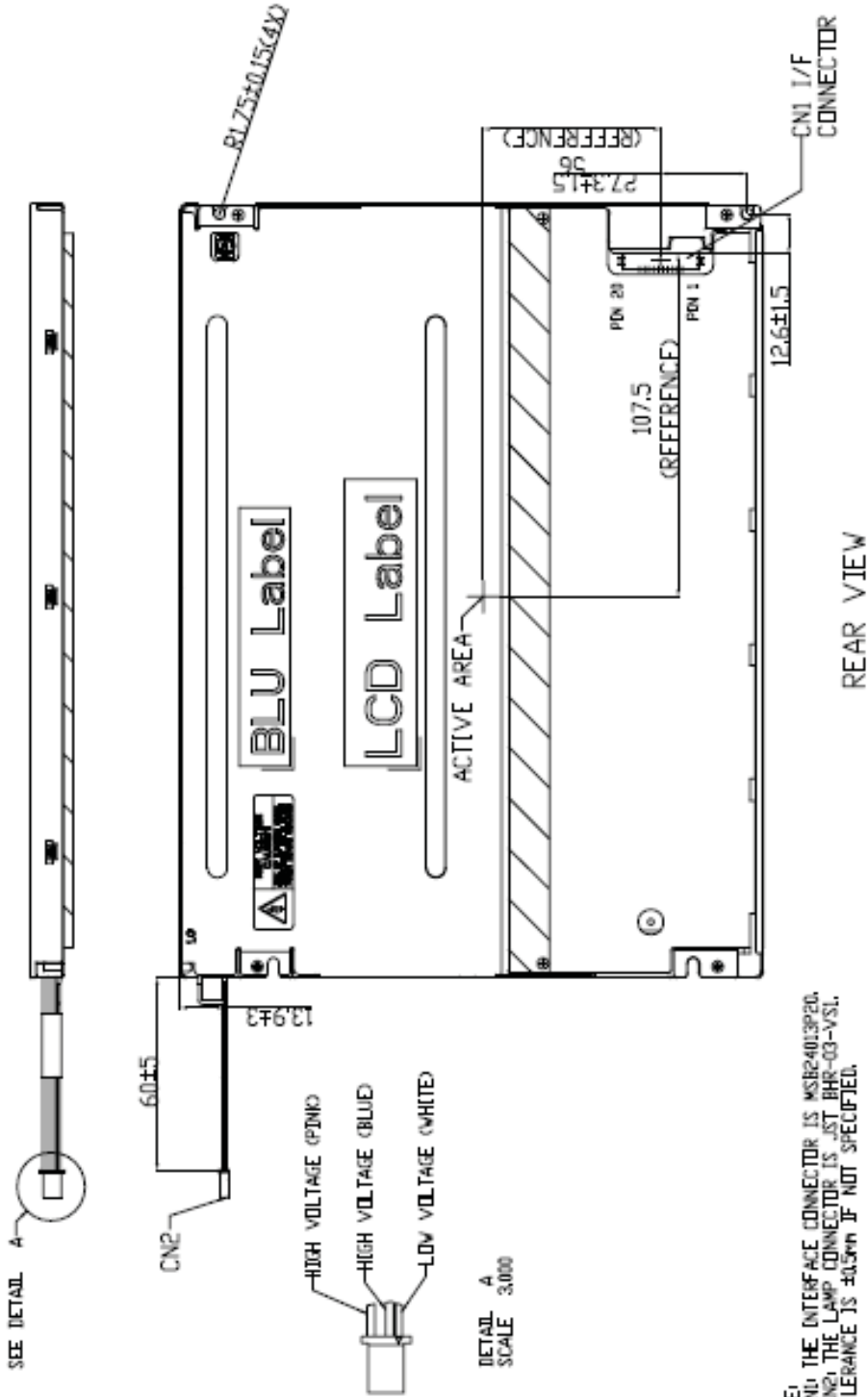

DETAIL A  
SCALE 3:000

NOTE:  
1. CN1: THE INTERFACE CONNECTOR IS MS824013P20.  
2. CN2: THE LAMP CONNECTOR IS JST BHR-03-VSL.  
3. TOLERANCE IS ±0.5mm IF NOT SPECIFIED.

CN2 PIN NO.	ELECTRODE	REMARK
1	LOW VOLTAGE	WHITE
2	HIGH VOLTAGE	BLUE
3	HIGH VOLTAGE	PINK

REAR VIEW



## 10. Label and Packaging

### 10.1 Shipping Label (on the rear side of TFT-LCD display)

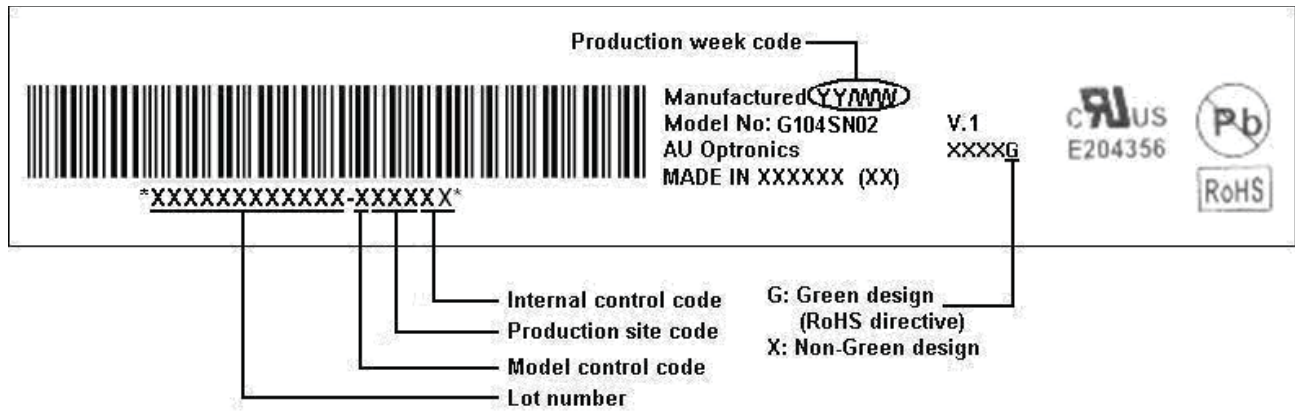

### 10.2 Carton Package

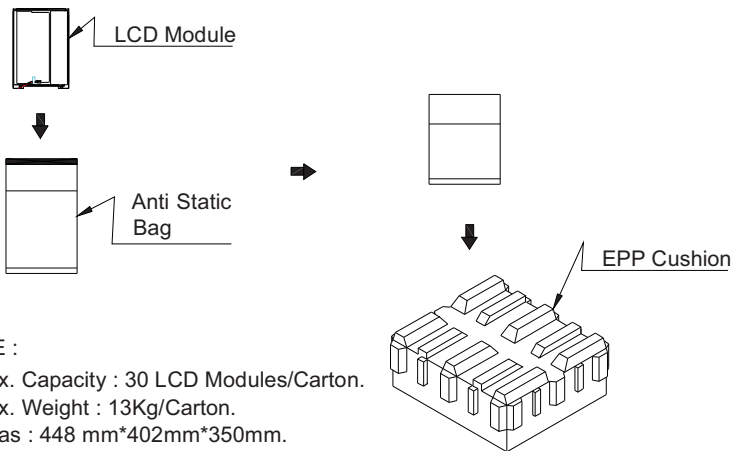

**NOTE :**

1. Max. Capacity : 30 LCD Modules/Carton.
2. Max. Weight : 13Kg/Carton.
3. Meas : 448 mm\*402mm\*350mm.

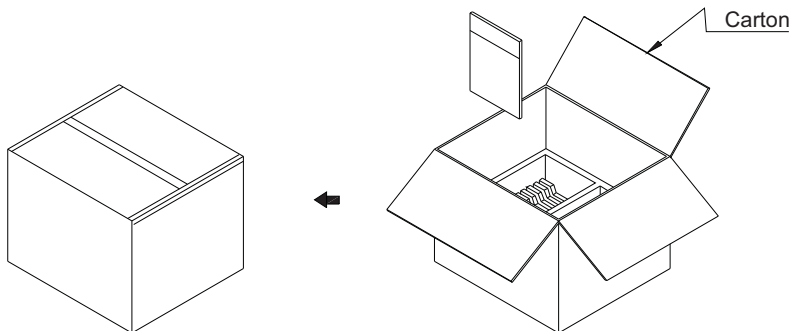

CONFIDENTIAL



## 11 Safety

### 11.1 Sharp Edge Requirements

There will be no sharp edges or comers on the display assembly that could cause injury.

### 11.2 Materials

#### 11.2.1 Toxicity

There will be no carcinogenic materials used anywhere in the display module. If toxic materials are used, they will be reviewed and approved by the responsible AUO toxicologist.

#### 11.2.2 Flammability

All components including electrical components that do not meet the flammability grade UL94-V1 in the module will complete the flammability rating exception approval process.

The printed circuit board will be made from material rated 94-V1 or better. The actual UL flammability rating will be printed on the printed circuit board.

### 11.3 Capacitors

If any polarized capacitors are used in the display assembly, provisions will be made to keep them from being inserted backwards.

### 11.4 National Test Lab Requirement

The display module will satisfy all requirements for compliance to:

UL 60950

U.S.A. Information Technology Equipment

CONFIDENTIAL



# US Micro Products

*Electronic Products for the OEM*

Los Angeles • Austin • New York • Orlando • Shenzhen

(800) 741-7755

[www.usmicroproducts.com](http://www.usmicroproducts.com)

## Displays

US Micro Products is an industrial distributor specializing in engineered display solutions. We dedicate ourselves to providing the best in displays for the medical, industrial, gaming, automotive, aerospace, military, and consumer markets.

### OLEDs



### TFT Displays



### Open Frame Monitors



### Passive LCDs



### Multitouch



As a customer, you benefit from our expert knowledge, support and service which allow quick selection and design-in of the best display for your application. On hand stock and demo boards facilitate quick access and evaluation to get you going fast. Our technical sales staff and experienced design engineers provide answers to your questions as well as engineered solutions to solve your display needs.

## Peripheral Devices

Our full line of peripheral devices includes keyboards, trackballs, and printers. These rugged industrial products are designed to meet your demanding requirements and are available as both standard and custom solutions.

### Keyboards



### Trackballs



### Aerospace Trackballs



### Joysticks



### Printers

