



US Micro Products

ENGINEERED DISPLAY SOLUTIONS

PRODUCT SPECIFICATION

MANUFACTURED BY

INNOLUX

INNOLUX CORPORATION

PART NUMBER

USMP-G070Y2-T02

7.0" IAV WVGA (800 x 480 pixels) LVDS
TFT LCD module with a LED backlight
unit and a-60-pin-and-1ch-TTL interface,
262.144 / 16M Full Color.

ISSUE DATE	APPROVED BY	CHECKED BY	PREPARED BY
PROPRIETARY NOTE	THIS SPECIFICATION IS THE PROPERTY OF US MICRO PRODUCTS AND SHALL NOT BE REPRODUCED OR COPIED WITHOUT THE WRITTEN PERMISSION OF US MICRO PRODUCTS AND MUST BE RETURNED TO US MICRO PRODUCTS UPON ITS REQUEST.		

TFT LCD Approval Specification

MODEL NO.: G070Y2-T02

Customer: _____

Approved by: _____

Note:

CONFIDENTIAL

核准時間	部門	審核	角色	投票
2010-09-15 09:13:48	APPL 產品管理處	張喻翔	Director	Accept

- CONTENTS -

REVISION HISTORY	-----	3
1. GENERAL DESCRIPTION	-----	4
1.1 OVERVIEW		
1.2 FEATURES		
1.3 APPLICATION		
1.4 GENERAL SPECIFICATIONS		
1.5 MECHANICAL SPECIFICATIONS		
2. ABSOLUTE MAXIMUM RATINGS	-----	6
2.1 ABSOLUTE RATINGS OF ENVIRONMENT		
2.2 ELECTRICAL ABSOLUTE RATINGS		
2.2.1 TFT LCD MODULE		
2.2.2 BACKLIGHT UNIT		
3. ELECTRICAL CHARACTERISTICS	-----	8
3.1 RECOMMENDED OPERATING CONDITION		
3.2 CURRENT CONSUMPTION		
3.3 BACKLIGHT UNIT		
4. BLOCK DIAGRAM	-----	10
4.1 TFT LCD MODULE		
4.2 BACKLIGHT UNIT		
5. INPUT TERMINAL PIN ASSIGNMENT	-----	11
5.1 FPC I/O PIN ASSIGNMENT		
5.2 BACKLIGHT DRIVING SECTION		
5.3 SCANNING DIRECTION		
5.4 COLOR DATA INPUT ASSIGNMENT		
6. INTERFACE TIMING	-----	16
6.1 AC ELECTRICAL CHARACTERISTICS		
6.2 POWER ON/OFF SEQUENCE		
7. OPTICAL CHARACTERISTICS	-----	19
7.1 TEST CONDITIONS		
7.2 OPTICAL SPECIFICATIONS		
8. RELIABILITY TEST	-----	22
9. PACKAGING	-----	23
10. DEFINITION OF LABELS	-----	25
11. PRECAUTIONS	-----	26
12. MECHANICAL CHARACTERISTICS	-----	27

CONFIDENTIAL

REVISION HISTORY

Version	Date	Section	Description
Ver 2.0	Nov. 05, '09	All	G070Y2-T02 Approval specification was first issued.
Ver 2.1	May.11, '10	1.4	Module Power Consumption from 3.31 W to 3.45 W
		2.2.2	LED Light Bar Power Supply Voltage max. from 28V to 31.5V
		3.3	LED Light Bar Power Supply Voltage Typ. from 224.5V to 28V Max. from 28V to 31.5V
			LED Light Bar Power Supply Current Typ. form 120mA to 110mA
			Power Consumption from 2.94W to 3.08W
			Note(4) $I_L = 60 \text{ mA(Per EA)}$ change to $I_L = 55 \text{ mA(Per EA)}$
		7.1	TEST CONDITIONS Current from $60 \pm 4 \text{ mA}$ to $55 \pm 3 \text{ mA}$
Ver 2.2	Sep.13, '10	3.3	Add Note(5)

CONFIDENTIAL

1. GENERAL DESCRIPTION

1.1 OVERVIEW

G070Y2-T02 is a 7inch TFT Liquid Crystal Display module with a LED backlight unit and a-60-pin-and-1ch-TTL interface. TCON (timing controller) is included in driver IC. This module supports 800 (R.G.B)x 480 WVGA mode which main application is the automotive display and industrial field.

1.2 FEATURES

- Wide viewing angle.
- Fast response time
- High Color Gamut
- Wide operating temperature
- Reversible - scan function
- 6/8 bit convertible

1.3 APPLICATION

- Automotive Display
- Industry Application

1.4 GENERAL SPECIFICATIONS

Item	Specification	Unit	Note
Diagonal Size	7	inch	
Active Area	152.4x91.44	mm	(1)
Bezel Opening Area	154.6x93.64	mm	
Driver Element	a-si TFT active matrix	-	-
Pixel Number	800 x R.G.B. x 480	pixel	-
Pixel Pitch	0.1905 x 0.1905	mm	-
Pixel Arrangement	RGB vertical stripe	-	(2)
Display Colors	262k or 16.2M	color	-
Display Mode	Normal White	-	-
Surface Treatment	Anti-glare, Hard Coating (3H)	-	-
Module Power Consumption	3.45	W	Typ.

Note (1) Please refer to the attached drawings for more information of front and back outline dimensions.

Note (2)

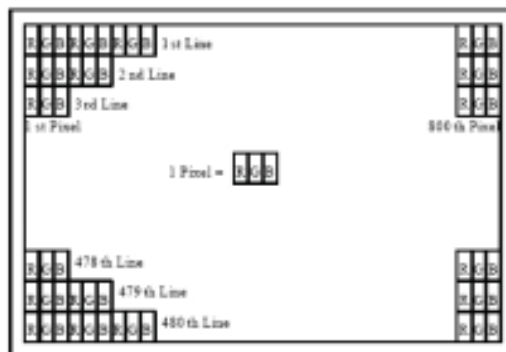

CONFIDENTIAL

1.5 MECHANICAL SPECIFICATIONS

Item	Min.	Typ.	Max.	Unit	Note	
Module Size	Horizontal (H)	164.7	165	165.3	mm	(1)
	Vertical (V)	103.7	104	104.3	mm	
	Depth (D)	5.83	6.33	6.83	mm	
Weight	117	132	147	g		

Note (1) Please refer to the attached drawings for more information of front and back outline dimensions.

CONFIDENTIAL

2. ABSOLUTE MAXIMUM RATINGS

2.1 ABSOLUTE RATINGS OF ENVIRONMENT

Item	Symbol	Value		Unit	Note
		Min.	Max.		
Operating Ambient Temperature	T _{OP}	-30	+85	°C	
Storage Temperature	T _{ST}	-40	+95	°C	

Note (1) Temperature and relative humidity range is shown in the figure below.

(2) Wet-bulb temperature should be 39 °C Max. (T_a > 40 °C).

(3) No condensation.

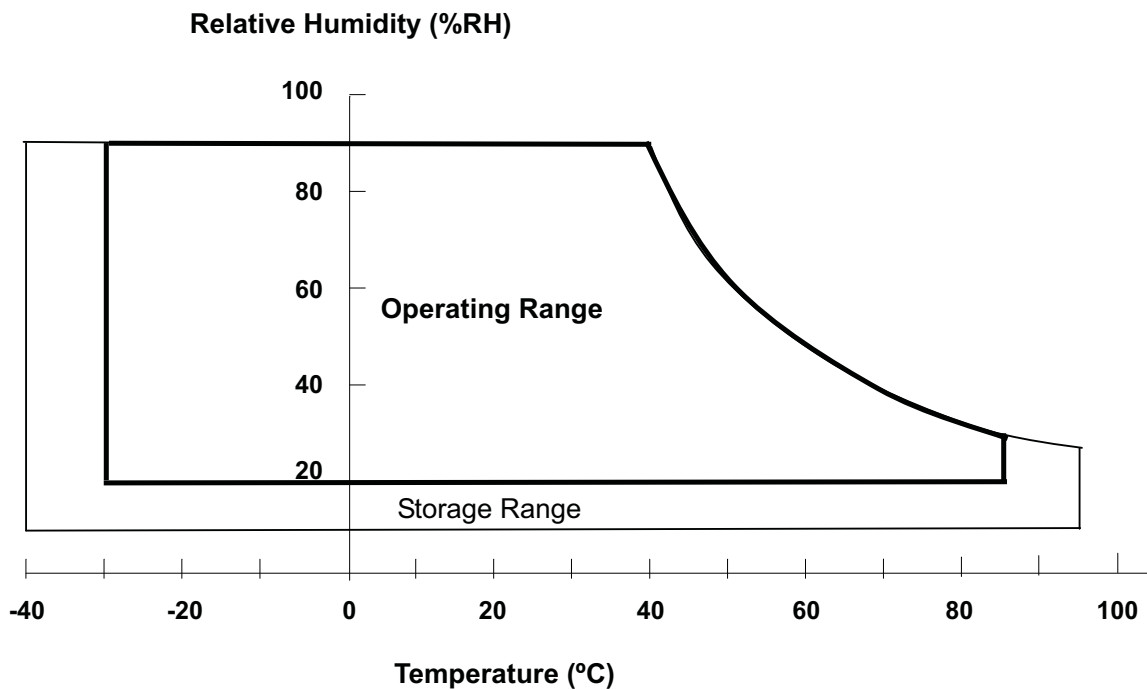

CONFIDENTIAL

2.2 ELECTRICAL ABSOLUTE RATINGS

2.2.1 TFT LCD MODULE

Ta = 25 ± 2 °C

Parameter	Symbol	Value		Unit	Note
		Min.	Max.		
Power Supply Voltage	VCC	-0.3	7	V	-
	VDDG	-0.3	7	V	
	AVDD	-0.3	13.5	V	-
	VGH	-0.3	42	V	
	VGL	VGH-42	0.3	V	-
Digital Input Voltage	V _I	-0.3	VCC +0.3	V	(1)
Gamma Supply Voltage	V1~V10	-0.3	AVDD+0.3	V	-

Note (1) V_I means all input logic signal.

(2) Device is subject to be damaged permanently if stresses beyond those absolute maximum ratings listed above.

2.2.2 BACKLIGHT UNIT

Ta = 25 ± 2 °C

Item	Symbol	Value		Unit	Note
		Min.	Max.		
LED Light Bar Power Supply Voltage	V _L	18.9	31.5	V	(1)
LED Light Bar Power Supply Current	I _L	-	160	mA	(1)

Note (1) Permanent damage to the device may occur if maximum or minimum values are exceeded. Function operation should be restricted to the conditions described under Normal Operating Conditions.

CONFIDENTIAL

3. ELECTRICAL CHARACTERISTICS

3.1 RECOMMENDED OPERATION CONDITION (GND = AVSS = 0V)

Ta = 25 ± 2 °C

Parameter	Symbol	Value			Unit	Note
		Min.	Typ.	Max.		
Power Supply Voltage	VCC	3.0	3.3	3.6	V	
	VDDG	3.0	3.3	3.6	V	
	AVDD	9	10	12	V	
	VGH	18	19	20	V	
	VGL	-8	-6.8	-6	V	
Input Signal Voltage	V1~V5	0.35AVDD		AVDD-0.5	V	
	V6~V10	0.3		0.65AVDD	V	
	VCOM		3.8		V	
Digital Input Voltage	High Level	V _{IH}	0.8V _{CC}	V _{CC}	V	I _{oL} =400uA
	Low Level	V _{IL}	0	0.2V _{CC}	V	I _{oH} =400uA

3.2 CURRENT CONSUMPTION (GND = AVSS =0V)

Parameter	Symbol	Value			Unit	Note
		Min.	Typ.	Max.		
Supply Current for Source/Gate Driver (Digital)	I _{CC}		22	25	mA	(1)
Supply Current for Source Driver (Analog)	I _{DD}		29	30	mA	(1)
Supply Current for Gate Driver (High Level)	I _{GG}		0.216	0.3	mA	(1)
Supply Current for Gate Driver (Low Level)	I _{EE}		0.213	0.3	mA	(1)

Note (1) The specified power supply current is under the conditions at VCC = 3.3 V, Ta = 25 ± 2 °C, f_v = 60 Hz, whereas a power dissipation check pattern below is displayed.

Black Pattern

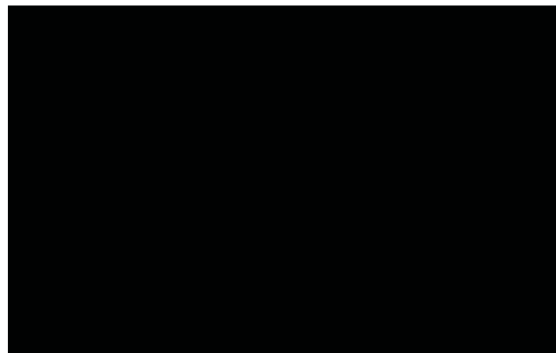

Active Area

3.3 BACKLIGHT UNIT

Ta = 25 ± 2 °C

Parameter	Symbol	Value			Unit	Note
		Min.	Typ.	Max.		
LED Light Bar Power Supply Voltage	V _L	18.9	28	31.5	V	
LED Light Bar Power Supply Current	I _L	--	110	--	mA	(1),(2),(3) (Duty 100%)
Power Consumption	P _L	--	3.08	--	W	
LED Life Time	L _{BL}	50000	==	==	hr	(4)

Note (1) LED light bar configuration is shown as below

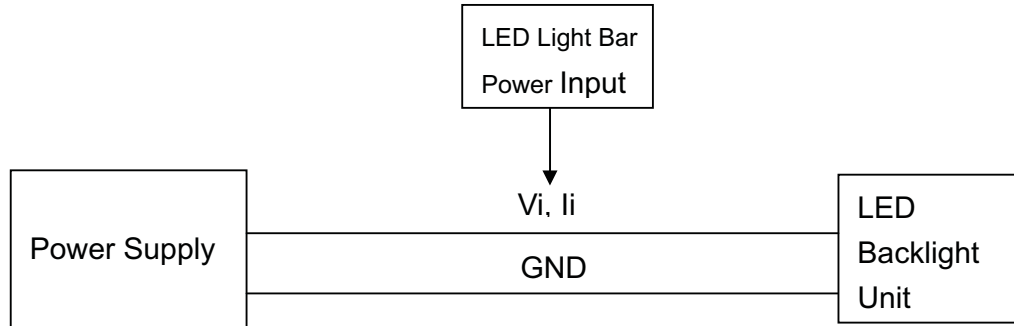

Note (2) For better LED light bar driving quality, it is recommended to utilize the adaptive boost converter with current balancing function to drive LED light-bar.

Note (3) $P_{Lmax} = I_{Lmax} \times V_{Lmax}$

Note (4) The lifetime of LED is defined as the time when it continues to operate under the conditions at Ta = 25 ± 2 °C and I_L = 55 mA(Per EA) until the brightness becomes ≤ 50% of its original value.

Note (5) Please note that LED life will be shorter than the average life described in the specification if operate in higher ambient temperature.

CONFIDENTIAL

4. BLOCK DIAGRAM
4.1 TFT LCD MODULE

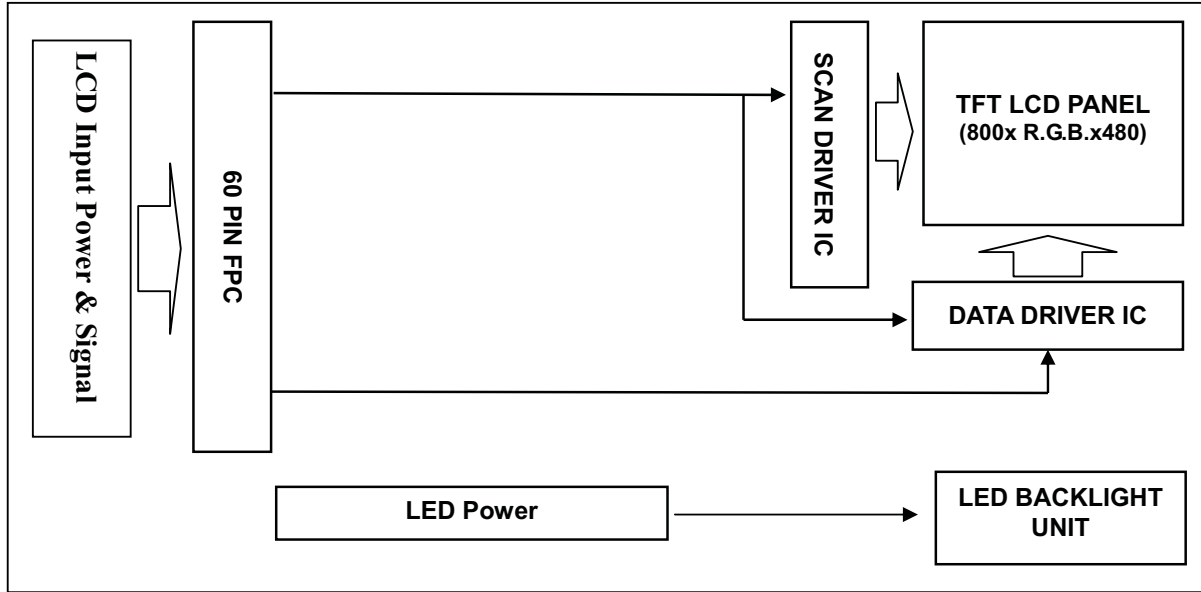

4.2 BACKLIGHT UNIT

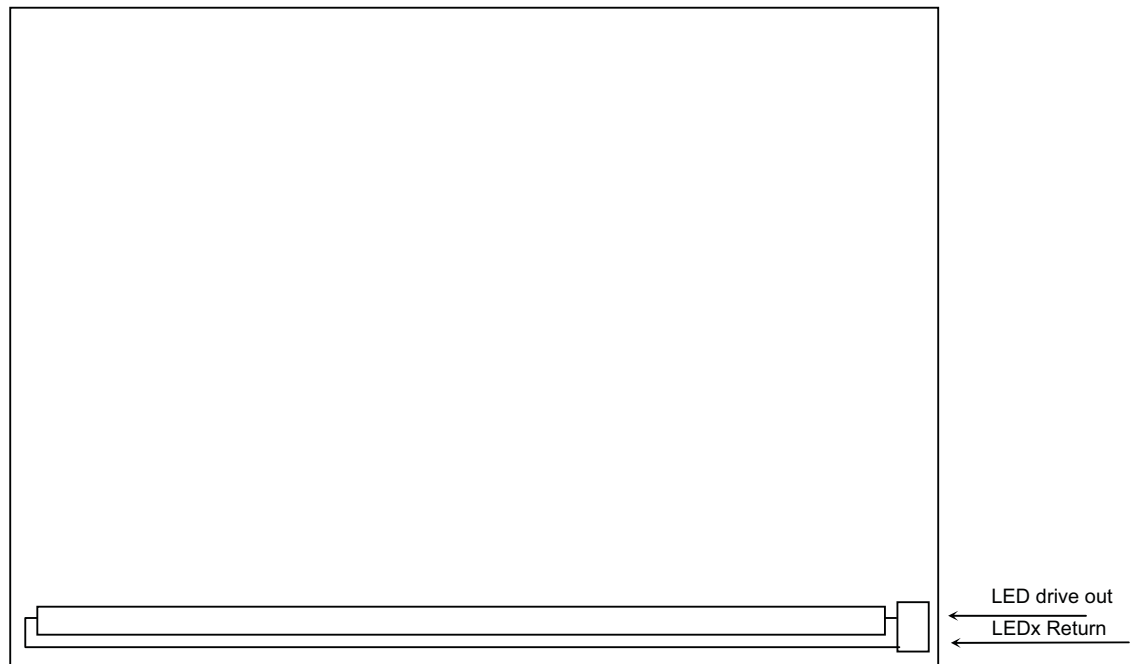

CONFIDENTIAL

5. INPUT TERMINAL PIN ASSIGNMENT

5.1 FPC I/O PIN ASSIGNMENT

Pin	Name	I/O	Description
1	GND	I	Power Ground
2	VGL	I	Gate OFF Power Supply Voltage
3	VGL	I	Gate OFF Power Supply Voltage
4	/XAO	I	Output all-on control When /XAO is set to L, all outputs are fixed to VGH
5	VDDG	I	Gate Driver Power supply (+3.3V)
6	VDDG	I	Gate Driver Power supply (+3.3V)
7	GND	I	Power Ground
8	VGH	I	Gate ON Power Supply Voltage
9	UD	I	Gate Driver Up/down scan setting When UD=H, reverse scan When UD=L, normal scan (Default pull low)
10	DE	I	Input data enable control When DE mode, active High to enable data input. (Default pull low)
11	FRC	I	Dithering control setting When FRC=H, the width of data input 8 bits When FRC=L, the width of data input 6 bits and set Dx0 and Dx1 to logical low (Default pull low)
12	B07	I	Blue data (MSB)
13	B06	I	Blue data
14	B05	I	Blue data
15	B04	I	Blue data
16	B03	I	Blue data
17	B02	I	Blue data
18	B01	I	Blue data
19	B00	I	Blue data (LSB)
20	CLK	I	Clock signal User can input different polarity CLK by EDGSL setting. (Default pull low)
21	GND	I	Power Ground
22	G07	I	Green data (MSB)
23	G06	I	Green data
24	G05	I	Green data
25	G04	I	Green data
26	G03	I	Green data
27	G02	I	Green data
28	G01	I	Green data
29	G00	I	Green data (LSB)
30	R07	I	Red data (MSB)
31	R06	I	Red data
32	R05	I	Red data
33	R04	I	Red data
34	R03	I	Red data
35	R02	I	Red data

36	R01	I	Red data
37	R00	I	Red data (LSB)
38	RESETB	I	Hardware global reset. Low active (Default pull high)
39	EDGSL	I	Define input clock polarity When EDGSL=L, Latch data by rising edge of CLK (Default Pull Low) When EDGSL=H, CLK polarity is inverted, Latch data by falling edge of CLK
40	LR	I	Shift direction of Source Driver IC internal shift register is controlled by this pin as show below: LR=H SO1→SO1200 (Default pull high) LR=L SO1200→.....SO1
41	GND	I	Power Ground
42	VCOM	I	Common voltage input
43	VCOM	I	Common voltage input
44	VCOM_Cst	I	Power Ground
45	VCC	I	Digital power supply (+3.3V)
46	VCC	I	Digital power supply (+3.3V)
47	AVDD	I	Analog power supply (+12V)
48	AVDD	I	Analog power supply (+12V)
49	GM1	I	Gamma voltage level 1
50	GM2	I	Gamma voltage level 2
51	GM3	I	Gamma voltage level 3
52	GM4	I	Gamma voltage level 4
53	GM5	I	Gamma voltage level 5
54	GM6	I	Gamma voltage level 6
55	GM7	I	Gamma voltage level 7
56	GM8	I	Gamma voltage level 8
57	GM9	I	Gamma voltage level 9
58	GM10	I	Gamma voltage level 10
59	VSSA	I	Power Ground
60	GND	I	Power Ground

5.2 BACKLIGHT DRIVING SECTION

No	Symbol	I/O	Description
1	HI	I	Power supply for backlight unit (High Voltage)
2	GND	-	GND for backlight unit

Note (1) User's connector Part No: Aces 87210 0236L

5.3 SCANNING DIRECTION

The following figures are seen from a front view and the arrow shows the direction of scan.

Fig.1 Normal Scan



Fig.2 Reverse Scan



Fig.3 Reverse Scan



Fig.4 Reverse Scan



- Fig. 1 Normal scan (pin 40, LR = High ; pin 9, UD = Low)
- Fig. 2 Reverse scan (pin 40, LR = Low ; pin 9, UD = Low)
- Fig. 3 Reverse scan (pin 40, LR = High ; pin 9, UD = High)
- Fig. 4 Reverse scan (pin 40, LR = Low ; pin 9, UD = High)

CONFIDENTIAL

5.4 COLOR DATA INPUT ASSIGNMENT

The brightness of each primary color (red, green and blue) is based on the 6-bit gray scale data input for the color. The higher the binary input, the brighter the color. The table below provides the assignment of color versus data input. (0: Low Level Voltage, 1: High Level Voltage)

Color		Data Signal																	
		Red						Green						Blue					
		R5	R4	R3	R2	R1	R0	G5	G4	G3	G2	G1	G0	B5	B4	B3	B2	B1	B0
Basic Colors	Black	0	0	0	0	0	0	0	0	0	0	0	0	0	0	0	0	0	0
	Red	1	1	1	1	1	1	0	0	0	0	0	0	0	0	0	0	0	0
	Green	0	0	0	0	0	0	1	1	1	1	1	1	0	0	0	0	0	0
	Blue	0	0	0	0	0	0	0	0	0	0	0	0	1	1	1	1	1	1
	Cyan	0	0	0	0	0	0	1	1	1	1	1	1	1	1	1	1	1	1
	Magenta	1	1	1	1	1	1	0	0	0	0	0	0	0	1	1	1	1	1
	Yellow	1	1	1	1	1	1	1	1	1	1	1	1	0	0	0	0	0	0
	White	1	1	1	1	1	1	1	1	1	1	1	1	1	1	1	1	1	1
Gray Scale Of Red	Red(0) / Dark	0	0	0	0	0	0	0	0	0	0	0	0	0	0	0	0	0	0
	Red(1)	0	0	0	0	0	1	0	0	0	0	0	0	0	0	0	0	0	0
	Red(2)	0	0	0	0	1	0	0	0	0	0	0	0	0	0	0	0	0	0
	⋮	⋮	⋮	⋮	⋮	⋮	⋮	⋮	⋮	⋮	⋮	⋮	⋮	⋮	⋮	⋮	⋮	⋮	⋮
	⋮	⋮	⋮	⋮	⋮	⋮	⋮	⋮	⋮	⋮	⋮	⋮	⋮	⋮	⋮	⋮	⋮	⋮	⋮
	Red(61)	1	1	1	1	0	1	0	0	0	0	0	0	0	0	0	0	0	0
	Red(62)	1	1	1	1	1	0	0	0	0	0	0	0	0	0	0	0	0	0
	Red(63)	1	1	1	1	1	1	0	0	0	0	0	0	0	0	0	0	0	0
Gray Scale Of Green	Green(0) / Dark	0	0	0	0	0	0	0	0	0	0	0	0	0	0	0	0	0	0
	Green(1)	0	0	0	0	0	0	0	0	0	0	0	1	0	0	0	0	0	0
	Green(2)	0	0	0	0	0	0	0	0	0	0	1	0	0	0	0	0	0	0
	⋮	⋮	⋮	⋮	⋮	⋮	⋮	⋮	⋮	⋮	⋮	⋮	⋮	⋮	⋮	⋮	⋮	⋮	⋮
	⋮	⋮	⋮	⋮	⋮	⋮	⋮	⋮	⋮	⋮	⋮	⋮	⋮	⋮	⋮	⋮	⋮	⋮	⋮
	Green(61)	0	0	0	0	0	0	1	1	1	1	0	1	0	0	0	0	0	0
	Green(62)	0	0	0	0	0	0	1	1	1	1	1	0	0	0	0	0	0	0
	Green(63)	0	0	0	0	0	0	1	1	1	1	1	1	0	0	0	0	0	0
Gray Scale Of Blue	Blue(0) / Dark	0	0	0	0	0	0	0	0	0	0	0	0	0	0	0	0	0	0
	Blue(1)	0	0	0	0	0	0	0	0	0	0	0	0	0	0	0	0	0	1
	Blue(2)	0	0	0	0	0	0	0	0	0	0	0	0	0	0	0	0	1	0
	⋮	⋮	⋮	⋮	⋮	⋮	⋮	⋮	⋮	⋮	⋮	⋮	⋮	⋮	⋮	⋮	⋮	⋮	⋮
	⋮	⋮	⋮	⋮	⋮	⋮	⋮	⋮	⋮	⋮	⋮	⋮	⋮	⋮	⋮	⋮	⋮	⋮	⋮
	Blue(61)	0	0	0	0	0	0	0	0	0	0	0	0	1	1	1	1	0	1
	Blue(62)	0	0	0	0	0	0	0	0	0	0	0	0	1	1	1	1	1	0
	Blue(63)	0	0	0	0	0	0	0	0	0	0	0	0	1	1	1	1	1	1

CONFIDENTIAL

The brightness of each primary color (red, green and blue) is based on the 8-bit gray scale data input for the color. The higher the binary input, the brighter the color. The table below provides the assignment of color versus data input.
(0: Low Level Voltage, 1: High Level Voltage)

Color		Data Signal																							
		Red								Green								Blue							
		R7	R6	R5	R4	R3	R2	R1	R0	G7	G6	G5	G4	G3	G2	G1	G0	B7	B6	B5	B4	B3	B2	B1	B0
Basic Colors	Black	0	0	0	0	0	0	0	0	0	0	0	0	0	0	0	0	0	0	0	0	0	0	0	0
	Red	1	1	1	1	1	1	1	1	0	0	0	0	0	0	0	0	0	0	0	0	0	0	0	0
	Green	0	0	0	0	0	0	0	0	1	1	1	1	1	1	1	1	0	0	0	0	0	0	0	0
	Blue	0	0	0	0	0	0	0	0	0	0	0	0	0	0	0	0	1	1	1	1	1	1	1	1
	Cyan	0	0	0	0	0	0	0	0	1	1	1	1	1	1	1	1	1	1	1	1	1	1	1	1
	Magenta	1	1	1	1	1	1	1	1	0	0	0	0	0	0	0	0	1	1	1	1	1	1	1	1
	Yellow	1	1	1	1	1	1	1	1	1	1	1	1	1	1	1	1	0	0	0	0	0	0	0	0
	White	1	1	1	1	1	1	1	1	1	1	1	1	1	1	1	1	1	1	1	1	1	1	1	1
Gray Scale Of Red	Red(0) / Dark	0	0	0	0	0	0	0	0	0	0	0	0	0	0	0	0	0	0	0	0	0	0	0	0
	Red(1)	0	0	0	0	0	0	0	1	0	0	0	0	0	0	0	0	0	0	0	0	0	0	0	0
	Red(2)	0	0	0	0	0	0	1	0	0	0	0	0	0	0	0	0	0	0	0	0	0	0	0	0
	⋮	⋮	⋮	⋮	⋮	⋮	⋮	⋮	⋮	⋮	⋮	⋮	⋮	⋮	⋮	⋮	⋮	⋮	⋮	⋮	⋮	⋮	⋮	⋮	⋮
	⋮	⋮	⋮	⋮	⋮	⋮	⋮	⋮	⋮	⋮	⋮	⋮	⋮	⋮	⋮	⋮	⋮	⋮	⋮	⋮	⋮	⋮	⋮	⋮	⋮
	Red(253)	1	1	1	1	1	1	0	1	0	0	0	0	0	0	0	0	0	0	0	0	0	0	0	0
	Red(254)	1	1	1	1	1	1	1	0	0	0	0	0	0	0	0	0	0	0	0	0	0	0	0	0
	Red(255)	1	1	1	1	1	1	1	1	0	0	0	0	0	0	0	0	0	0	0	0	0	0	0	0
Gray Scale Of Green	Green(0) / Dark	0	0	0	0	0	0	0	0	0	0	0	0	0	0	0	0	0	0	0	0	0	0	0	0
	Green(1)	0	0	0	0	0	0	0	0	0	0	0	0	0	0	1	0	0	0	0	0	0	0	0	0
	Green(2)	0	0	0	0	0	0	0	0	0	0	0	0	0	1	0	0	0	0	0	0	0	0	0	0
	⋮	⋮	⋮	⋮	⋮	⋮	⋮	⋮	⋮	⋮	⋮	⋮	⋮	⋮	⋮	⋮	⋮	⋮	⋮	⋮	⋮	⋮	⋮	⋮	⋮
	⋮	⋮	⋮	⋮	⋮	⋮	⋮	⋮	⋮	⋮	⋮	⋮	⋮	⋮	⋮	⋮	⋮	⋮	⋮	⋮	⋮	⋮	⋮	⋮	⋮
	Green(253)	0	0	0	0	0	0	0	1	1	1	1	1	1	1	0	1	0	0	0	0	0	0	0	0
	Green(254)	0	0	0	0	0	0	0	1	1	1	1	1	1	1	1	0	0	0	0	0	0	0	0	0
	Green(255)	0	0	0	0	0	0	0	1	1	1	1	1	1	1	1	1	0	0	0	0	0	0	0	0
Gray Scale Of Blue	Blue(0) / Dark	0	0	0	0	0	0	0	0	0	0	0	0	0	0	0	0	0	0	0	0	0	0	0	0
	Blue(1)	0	0	0	0	0	0	0	0	0	0	0	0	0	0	0	0	0	0	0	0	0	0	0	1
	Blue(2)	0	0	0	0	0	0	0	0	0	0	0	0	0	0	0	0	0	0	0	0	0	0	1	0
	⋮	⋮	⋮	⋮	⋮	⋮	⋮	⋮	⋮	⋮	⋮	⋮	⋮	⋮	⋮	⋮	⋮	⋮	⋮	⋮	⋮	⋮	⋮	⋮	⋮
	⋮	⋮	⋮	⋮	⋮	⋮	⋮	⋮	⋮	⋮	⋮	⋮	⋮	⋮	⋮	⋮	⋮	⋮	⋮	⋮	⋮	⋮	⋮	⋮	⋮
	Blue(253)	0	0	0	0	0	0	0	0	0	0	0	0	0	0	0	1	1	1	1	1	1	1	0	1
	Blue(254)	0	0	0	0	0	0	0	0	0	0	0	0	0	0	0	1	1	1	1	1	1	1	1	0
	Blue(255)	0	0	0	0	0	0	0	0	0	0	0	0	0	0	0	1	1	1	1	1	1	1	1	1

CONFIDENTIAL

6. INTERFACE TIMING

6.1 AC ELECTRICAL CHARACTERISTICS (VCC = V, AVDD = V, AVSS = GND = 0V, Ta = 25°C)

Parameter	Symbol	Value			Unit	Condition
		Min.	Typ.	Max.		
Data setup time	T _{dsu}	6			ns	
Data hold time	T _{dhd}	6			ns	
DE setup time	T _{esu}	6			ns	
CLK frequency	F _{CPH}	29.4	33.26	42.48	MHZ	
CLK period	T _{CPH}		30.06		ns	
CLK pulse duty	T _{CWH}	40	50	60	%	
DE period	T _{DEH} +T _{DEL}	1000	1056	1200	T _{CPH}	
DE pulse width	T _{DEH}		800		T _{CPH}	
DE frame blanking	T _{DEB}	10	45	110	T _{DEH} +T _{DEL}	
DE frame width	T _{DE}		480		T _{DEH} +T _{DEL}	

Timing Controller Timing Chart

■ Clock and Data input waveform

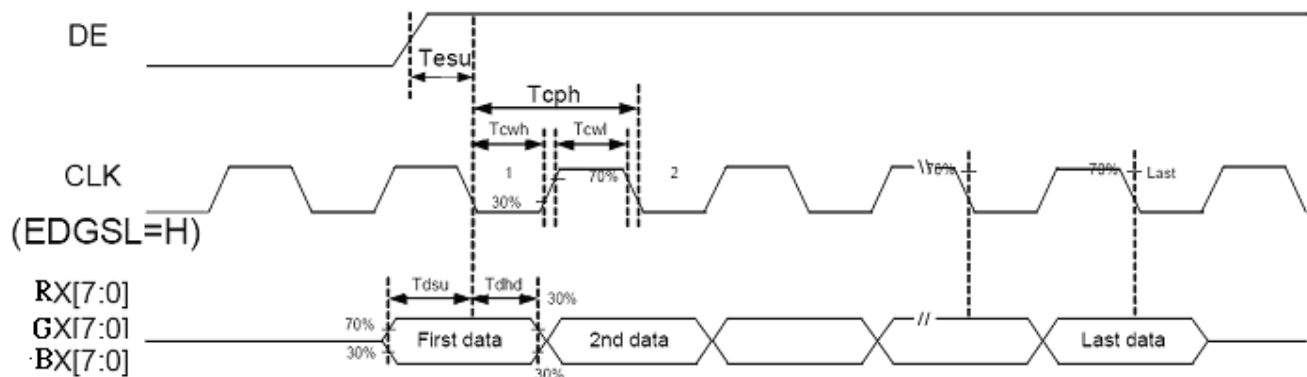
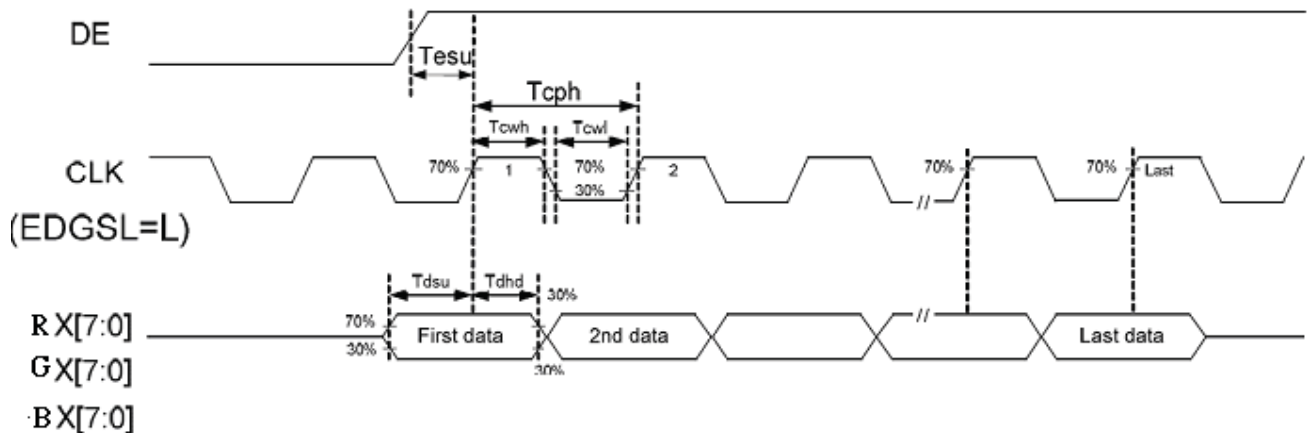

■ Data input format

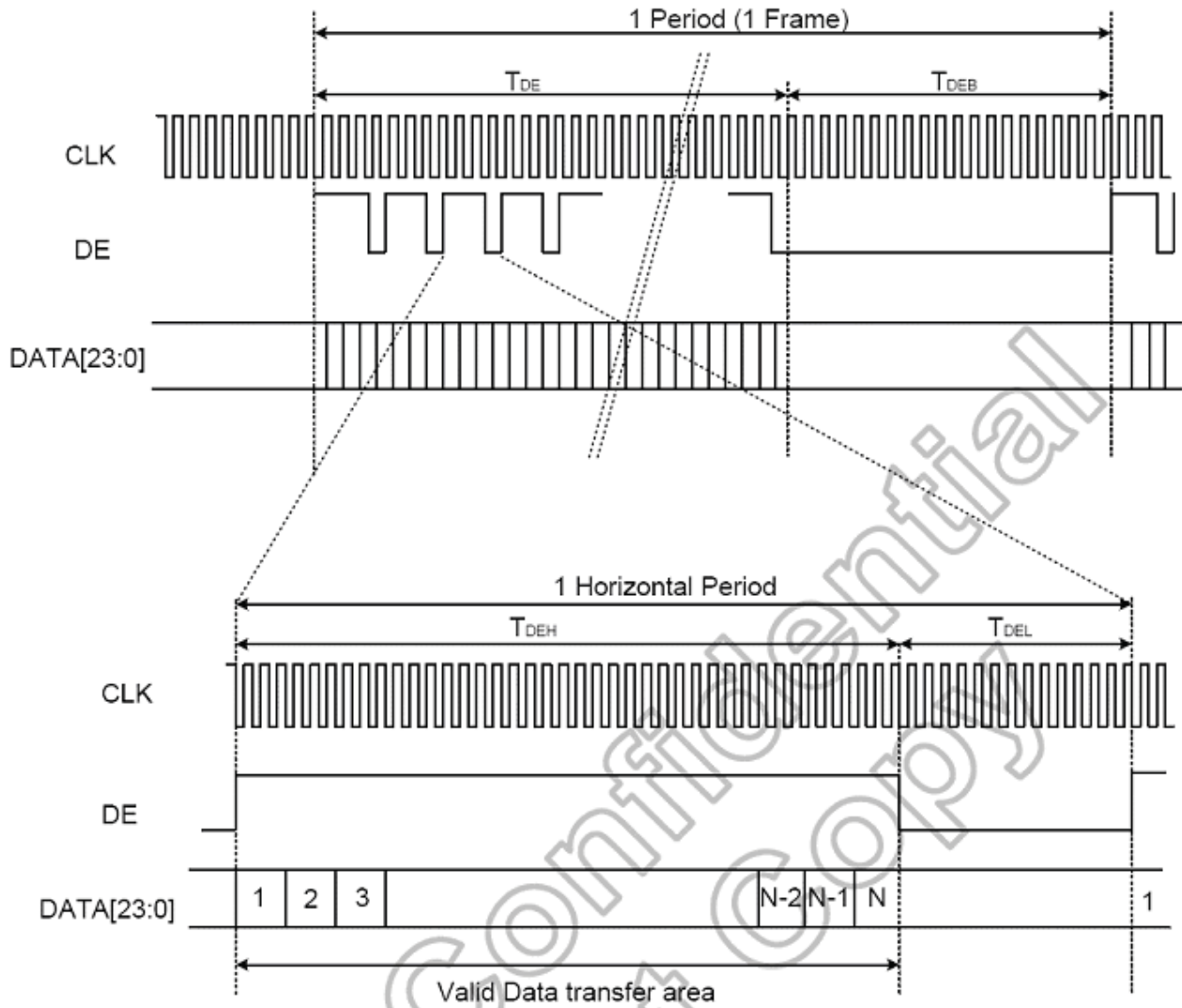

CONFIDENTIAL

6.2 POWER ON/OFF SEQUENCE

To prevent a latch-up or DC operation of LCD assembly, the power on/off sequence should be as the diagram below.

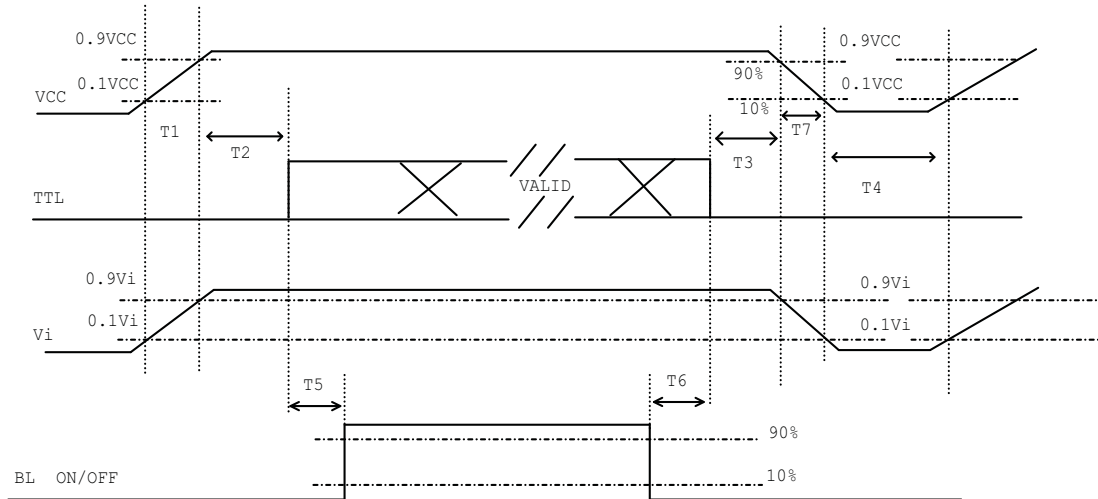

Power ON/OFF sequence

Note (1) Please avoid floating state of interface signal at invalid period.

Note (2) When the interface signal is invalid, be sure to pull down the power supply of LCD VCC to 0 V.

Note (3) The Backlight converter power must be turned on after the power supply for the logic and the interface signal is valid. The Backlight converter power must be turned off before the power supply for the logic and the interface signal is invalid.

Parameter	Value			Units
	Min	Typ	Max	
T1	0.5	-	10	ms
T2	0	-	50	ms
T3	0	-	50	ms
T4	500	-	-	ms
T5	20	-	-	ms
T6	10	-	-	ms
T7	5	-	300	ms

7. OPTICAL CHARACTERISTICS

7.1 TEST CONDITIONS

Item	Symbol	Value	Unit
Ambient Temperature	Ta	25±2	°C
Ambient Humidity	Ha	50±10	%RH
Supply Voltage	V _{CC}	3.3	V
Input Signal	According to typical value in "3. ELECTRICAL CHARACTERISTICS"		
Current	I _f	55±3	mA
Converter Duty		100	%

Note (1) I_f means the forward current of each channel

7.2 OPTICAL SPECIFICATIONS

The relative measurement methods of optical characteristics are shown in 7.2. The following items should be measured under the test conditions described in 7.1 and stable environment shown in Note (6).

Item		Symbol	Condition	Min.	Typ.	Max.	Unit	Note						
Color Chromaticity	Red	R _x	$\theta_x=0^\circ, \theta_y=0^\circ$ Viewing Normal Angle	Typ - 0.03	0.645	Typ + 0.03		(1), (6)						
		R _y			0.341									
	Green	G _x			0.312									
		G _y			0.625									
	Blue	B _x			0.153									
		B _y			0.053									
	White	W _x			0.313									
		W _y			0.329									
	Center Luminance of White				L _c					400	500		cd/m ²	(4), (6)
	Contrast Ratio				CR					500	600		-	(2), (6)
Response Time		T _R			5	10	Ms	(3)						
		T _F			11	16	Ms							
White Variation		δW			1.25	1.4	-	(5), (6)						
Viewing Angle	Horizontal	θ _{x+}	CR ≥ 10		60	70		Deg.	(1), (6)					
		θ _{x-}			60	70								
	Vertical	θ _{y+}			50	60								
		θ _{y-}			50	60								

CONFIDENTIAL

Note (1) Definition of Viewing Angle (θ_x , θ_y):

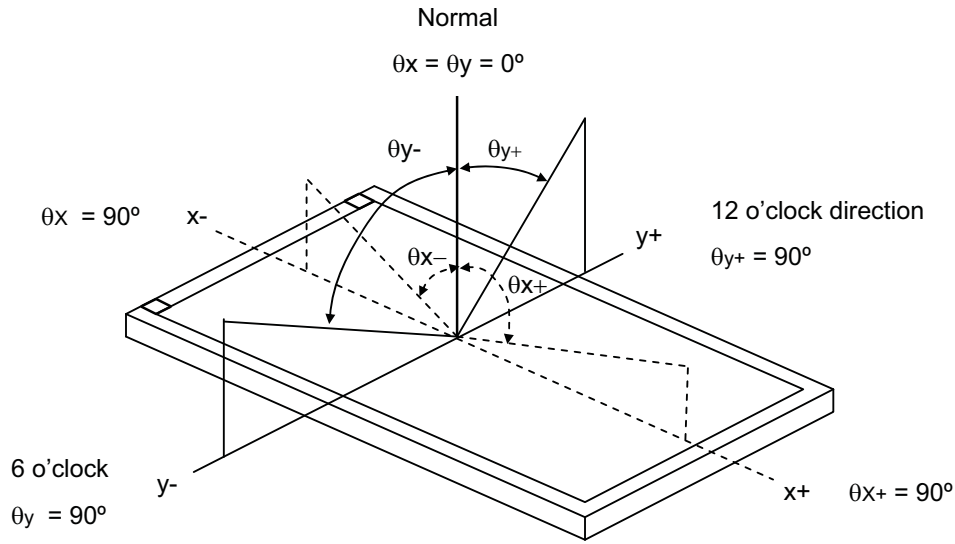

Note (2) Definition of Contrast Ratio (CR):

The contrast ratio can be calculated by the following expression.

$$\text{Contrast Ratio (CR)} = L_{63} / L_0$$

L63: Luminance of gray level 63

L 0: Luminance of gray level 0

$$CR = CR (5)$$

CR (X) is corresponding to the Contrast Ratio of the point X at Figure in Note (5).

Note (3) Definition of Response Time (T_R , T_F) and measurement method:

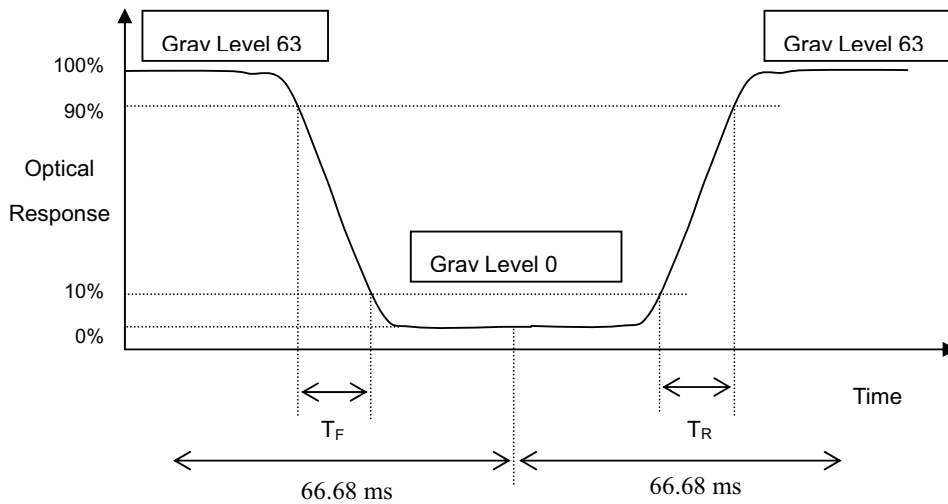

Note (4) Definition of Luminance of White (L_C):

Measure the luminance of gray level 63 at center point

$$L_C = L(5)$$

$L(x)$ is corresponding to the luminance of the point X at Figure in Note (5).

Note (5) Definition of White Variation (δW):

Measure the luminance of gray level 63 at 5 points

$$\delta W = \text{Maximum} [L(1), L(2), L(3), L(4), L(5)] / \text{Minimum} [L(1), L(2), L(3), L(4), L(5)]$$

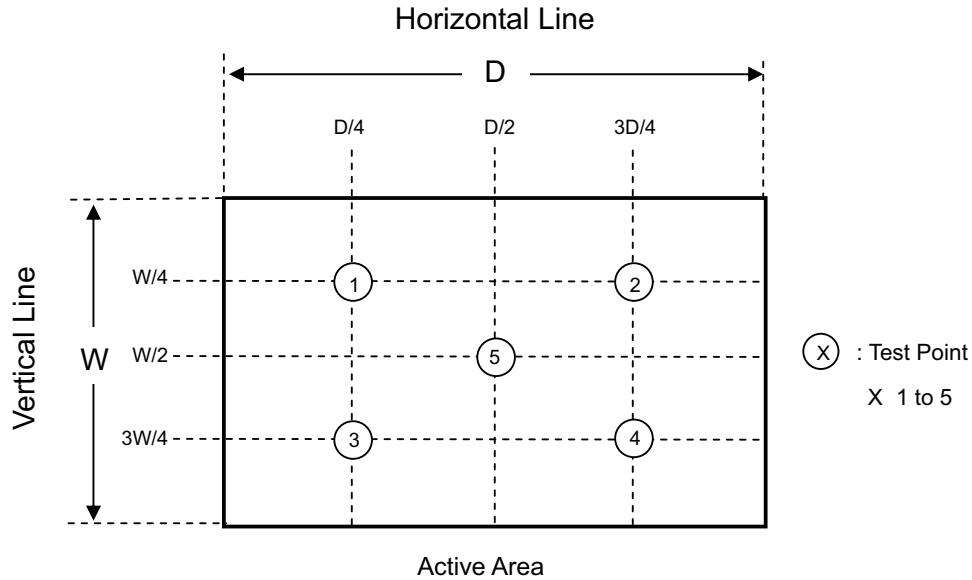

Note (6) Measurement Setup:

The LCD module should be stabilized at given temperature for 20 minutes to avoid abrupt temperature change during measuring. In order to stabilize the luminance, the measurement should be executed after lighting Backlight for 20 minutes in a windless room.

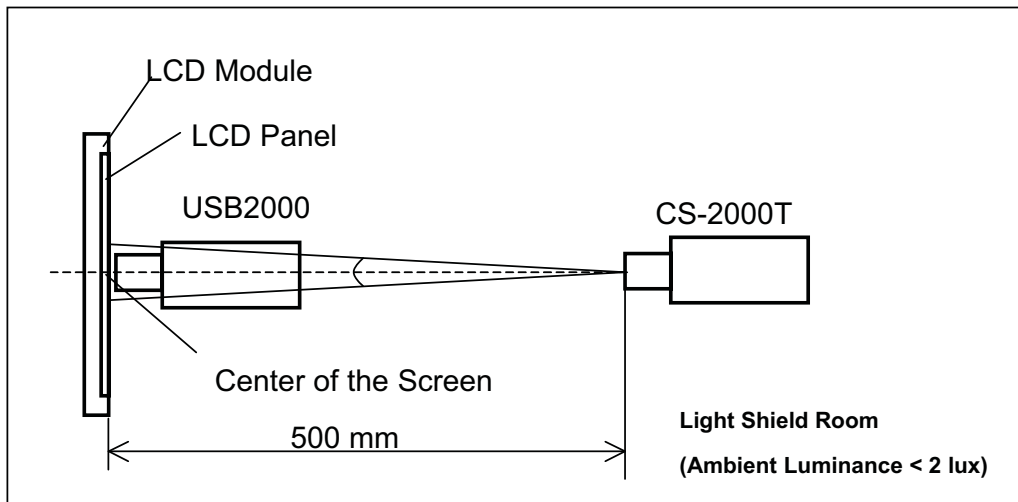

8. RELIABILITY TEST

No.	Test Item	Test Condition	Note
1	High Temperature Storage	95°C, 240 hours	(1) (2)
2	Low Temperature Storage	-40°C, 240 hours	
3	Thermal Shock Storage	{(-40°C, 0.5 hour) (85°C, 0.5 hour)}, 100 cycles	
4	High Temperature Operating	85°C, 240 hours	
5	Low Temperature Operating	-30°C, 240 hours	
6	High Temperature & High Humidity Operating	60°C, 90% RH, 240hours	
7	Shock (Non-Operating)	100G, 6ms, +/-XYZ 3 times	(3)(5)
8	Vibration (Non-Operating)	3G, 10 to 200 Hz, sine wave	(4)(5)

Note (1) There should be no condensation on the surface of panel during test.

Note (2) The temperature of panel display surface area should be 95°C Max.

Note (3) 6ms, half sine wave, 3 times for +/-X, +/-Y, +/-Z.

Note (4) 3 directions: X, Y and Z axes, 60min per each direction; 6 cycles; sweep time = 5 minutes; peak acceleration = 3G; frequency = 10 to 200 Hz; sine wave.

Note (5) At testing Vibration and Shock, the fixture in holding the module has to be hard and rigid enough so that the module would not be twisted or bent by the fixture.

Note (6) In the standard conditions, there is no function failure issue occurred. All the cosmetic specification is judged before the reliability test.

CONFIDENTIAL

9. PACKAGING

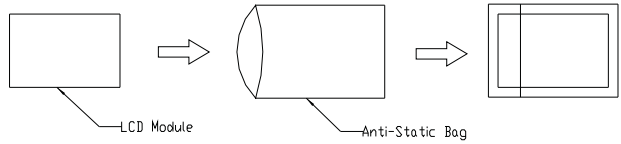

(1) 34pcs Modules/1 box

(2) Carton dimensions : 465(L)x362(W)x314(H)mm

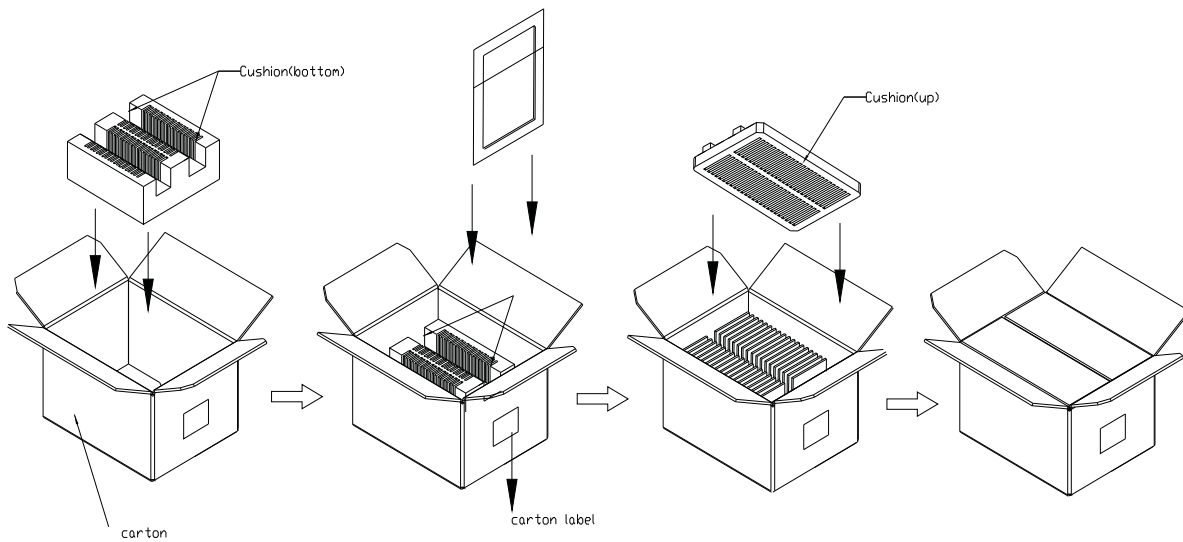

CONFIDENTIAL

Sea / Land Transportation (40ft Container)

Air Transportation

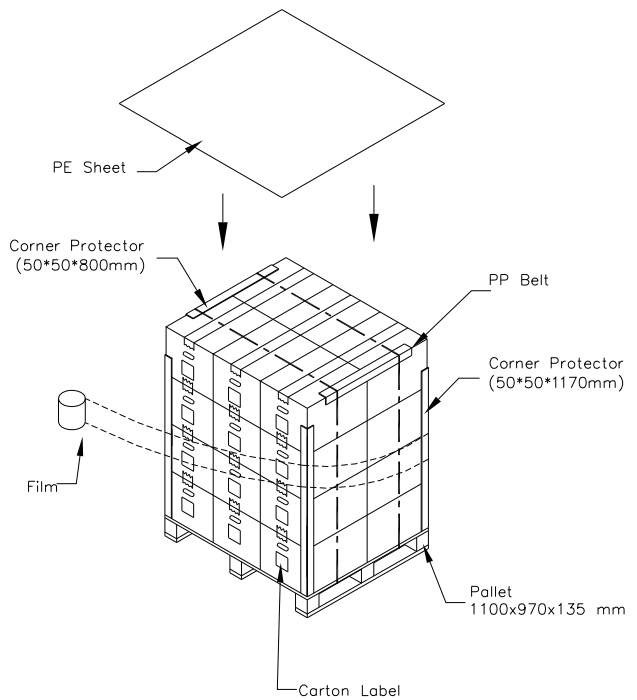
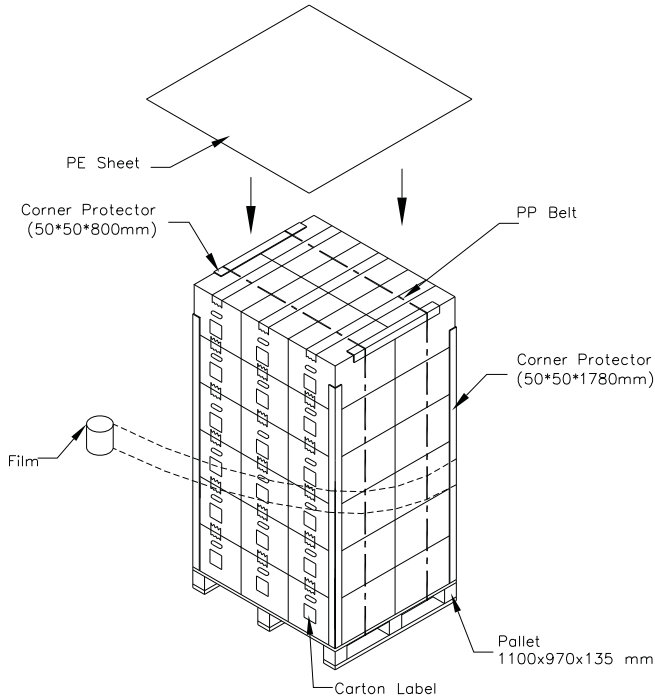

CONFIDENTIAL

10. DEFINITION OF LABELS

10.1 CMO MODULE LABEL

The barcode nameplate is pasted on each module as illustration, and its definitions are as following explanation.

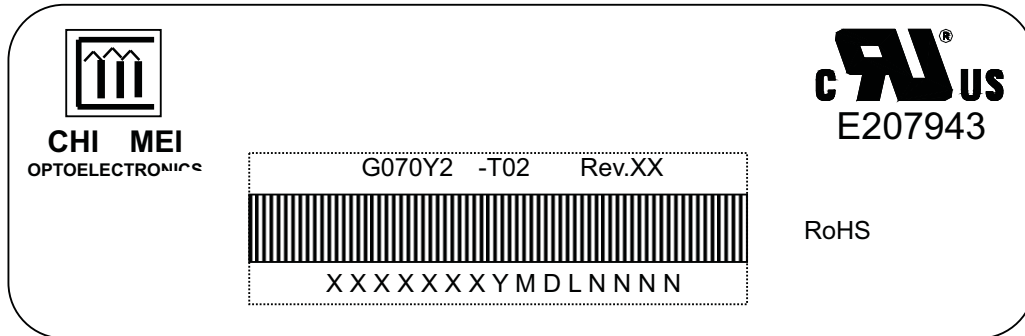

- (a) Model Name: G070Y2 - T02
- (b) Revision: Rev. XX, for example: A1, ..., C1, C2 ...etc.
- (c) Serial ID: XXXXXXXXYMDLNNNN

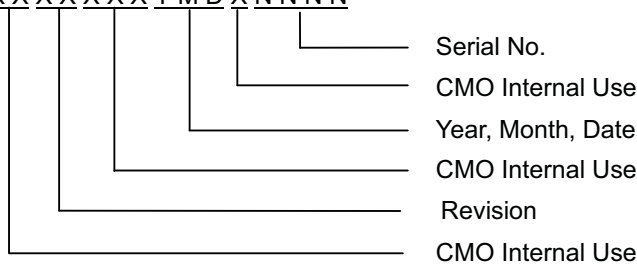

Serial ID includes the information as below:

- (a) Manufactured Date: Year: 1~9, for 2001~2009
Month: 1~9, A~C, for Jan. ~ Dec.
Day: 1~9, A~Y, for 1st to 31st, exclude I , O and U
- (b) Revision Code: cover all the change
Serial No.: Manufacturing sequence of product

CONFIDENTIAL

11. PRECAUTIONS

11.1 ASSEMBLY AND HANDLING PRECAUTIONS

- (1) Do not apply rough force such as bending or twisting to the module during assembly.
- (2) To assemble or install module into user's system can be only in clean working areas. The dust and oil may cause electrical short or worsen the polarizer.
- (3) It's not permitted to have pressure or impulse on the module because the LCD panel and Backlight will be damaged.
- (4) Always follow the correct power sequence when LCD module is connecting and operating. This can prevent damage to the CMOS LSI chips during latch-up.
- (5) Do not pull the I/F connector in or out while the module is operating.
- (6) Do not disassemble the module.
- (7) Use a soft dry cloth without chemicals for cleaning, because the surface of polarizer is very soft and easily scratched.
- (8) It is dangerous that moisture come into or contacted the LCD module, because moisture may damage LCD module when it is operating.
- (9) High temperature or humidity may reduce the performance of module. Please store LCD module within the specified storage conditions.
- (10) When ambient temperature is lower than 10°C may reduce the display quality. For example, the response time will become slowly, and the starting voltage of CCFL will be higher than room temperature.
- (11) Do not keep same pattern in a long period of time. It may cause image sticking on LCD

11.2 SAFETY PRECAUTIONS

- (1) Do not disassemble the module or insert anything into the Backlight unit to prevent electrical shock.
- (2) If the liquid crystal material leaks from the panel, it should be kept away from the eyes or mouth. In case of contact with hands, skin or clothes, it has to be washed away thoroughly with soap.
- (3) After the module's end of life, it is not harmful in case of normal operation and storage.

CONFIDENTIAL

CONFIDENTIAL



www.usmicroproducts.com

(800) 741-7755

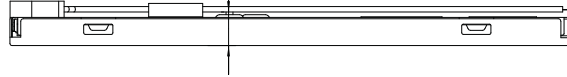
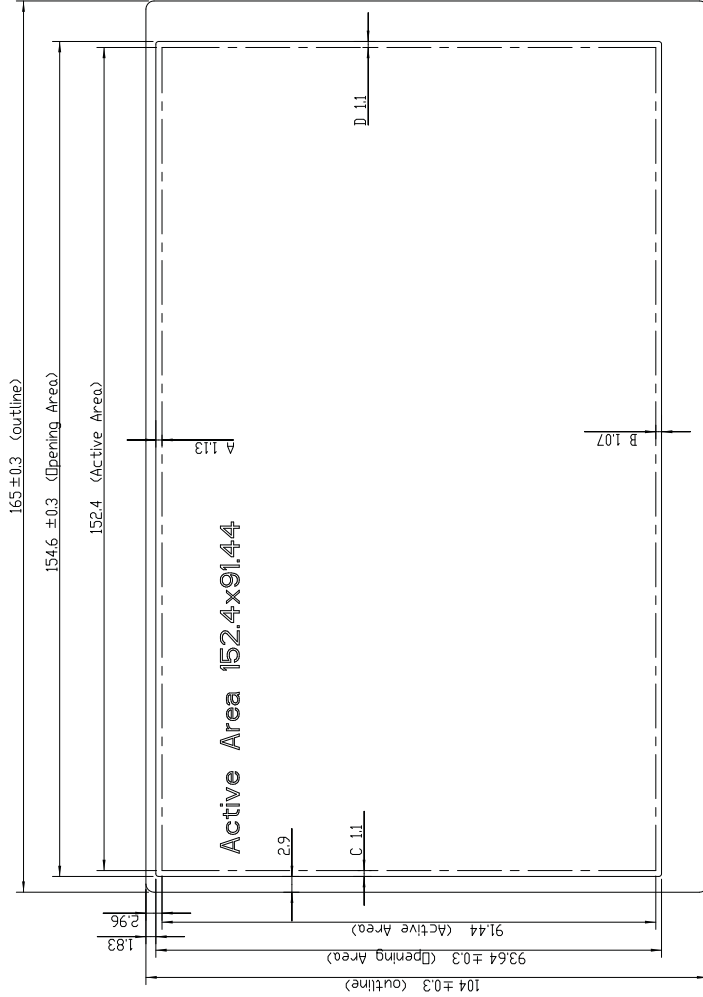

SCALE 3:2

- Note:
- UNSPECIFIED TOLERANCE = ± 0.3 mm.
 - DISPLAY AREA POSITION TOLERANCE: $A-B(K)=1$ mm & $C-D(J)=1$ mm.
 - VDS CONNECTOR: 73820-0048RA-G4 (Starconn).
 - P/I CONNECTOR: LM23S004HF13 (Unicorn).
 - THOSE SCREWS AT PCBA BOARD TO TWIST WITH FORCE IS 0.6 Kgf-cm AND REPEAT TIMES ≤ 4 .
 - THE WIRE IS UNDER THE PCB PROTECTOR FILM.

TITLE	ASSY_MIDDLE_07072-102	Drawing No.	TBD
Approved	KL_Lin	Checked	TIGER
Drawer	MIRCK_CHEN	Material	TBD
Designer	MIRCK_CHEN	Date	15-01-2009
		Sheet 1 / 2	A2
		Scale	1:1
		Unit	mm
		2D REV.	A
		3D REV.	124+

Mark	Description	Date	Changed_By	Approved_By	ECN No.	Remark

ALL RIGHTS RESERVED. COPYING FORBIDDEN.



CONFIDENTIAL



www.usmicroproducts.com

(800) 741-7755

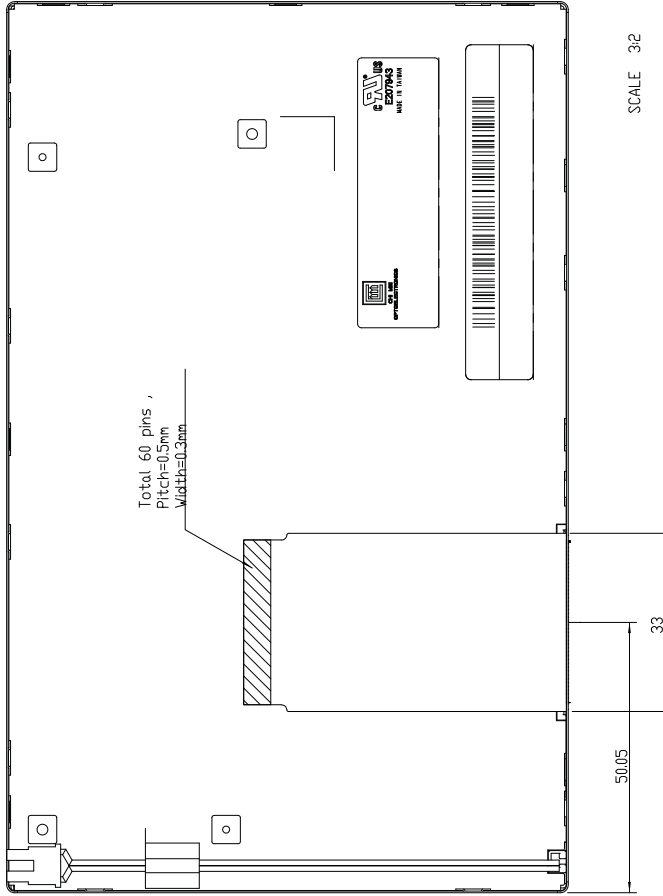

SCALE 3:2

- Note:
- 1.UNSPECIFIED TOLERANCE=±0.3mm.
 - 2.DISPLAY AREA POSITION TOLERANCE: IA-BK<=1mm & IC-DK<=1mm.
 - 3.LVDS CONNECTOR: 73B20-0048RA-G4 (Starcon).
 - 4.P/I CONNECTOR: LM23004HTF13 (Unicorn).
 - 5.THOSE SCREWS AT PCBA BOARD TO TWIST WITH FORCE IS 0.6 KgF-cm AND REPEAT TIMES<= 4.
 - 6.THE WIRE IS UNDER THE PCB PROTECTOR FILM.

TITLE	ASSY_MODULE_G07092-102	2D REV. A
Approved	KL_Lin	Drawing No. TBD
Checked	TIGER	Part No. TBD
Drawer	MIRDE_CHEN	Material TBD
Designer	MIRDE_CHEN	Date 15-DEC-2009
		Scale 1:1
		Sheet 2 / 2
		Unit:mm



ALL RIGHTS RESERVED. COPYING FORBIDDEN.

Mark	Description	Date	Changed_By	Approved_By	ECN No.	Remark