



US Micro Products

ENGINEERED DISPLAY SOLUTIONS

PRODUCT SPECIFICATION

MANUFACTURED BY

INNOLUX

INNOLUX CORPORATION

PART NUMBER

USMP-V500DK2-KS1

50" TFT Liquid Crystal Display module with LED Backlight unit and 8Lanes V-by-One HS interface. This module supports 3840 x 2160 Quad Full HDTV format and can display true 1.07G colors (8-bit+FRC).

ISSUE DATE	APPROVED BY	CHECKED BY	PREPARED BY
PROPRIETARY NOTE	THIS SPECIFICATION IS THE PROPERTY OF US MICRO PRODUCTS AND SHALL NOT BE REPRODUCED OR COPIED WITHOUT THE WRITTEN PERMISSION OF US MICRO PRODUCTS AND MUST BE RETURNED TO US MICRO PRODUCTS UPON ITS REQUEST.		

- Tentative Specification
- Preliminary Specification
- Approval Specification

MODEL NO.: V500DK2

SUFFIX: KS1

CONFIDENTIAL

Revision : <u>C8</u>	
Customer :	
APPROVED BY	SIGNATURE
Name / Title _____	
Note	

Please return 1 copy for your confirmation with your signature and comments.	

Approved By	Checked By	Prepared By
Chao-Chun Chung	Carlos Lee	WT Hsu

CONTENTS

CONTENTS..... 2

REVISION HISTORY 4
 Modify GENERAL SPECIFICATIONS..... 4

Modify MECHANICAL CHARACTERISTIC 4

1. GENERAL DESCRIPTION 5
 1.1 OVERVIEW 5
 1.2 FEATURES 5
 1.3 GENERAL SPECIFICATIONS..... 5
 1.4 MECHANICAL SPECIFICATIONS..... 6

2. ABSOLUTE MAXIMUM RATINGS 7
 2.1 ABSOLUTE RATINGS OF ENVIRONMENT..... 7
 2.2 PACKAGE STORAGE 8
 2.3 ELECTRICAL ABSOLUTE RATINGS..... 8
 2.3.1 TFT LCD MODULE..... 8
 2.3.2 BACKLIGHT CONVERTER UNIT 8

3. ELECTRICAL CHARACTERISTICS..... 9
 3.1 TFT LCD MODULE..... 9
 3.2 BACKLIGHT UNIT..... 12
 3.2.1 CONVERTER CHARACTERISTICS..... 12
 3.2.2 CONVERTER INTERFACE CHARACTERISTICS 14

4. BLOCK DIAGRAM OF INTERFACE 16
 4.1 TFT LCD MODULE..... 16

5. INPUT TERMINAL PIN ASSIGNMENT..... 17
 5.1 TFT LCD MODULE..... 17
 5.2 BACKLIGHT UNIT 21
 5.3 CONVERTER UNIT..... 22
 5.4 COLOR DATA INPUT ASSIGNMENT..... 24

6. INTERFACE TIMING..... 25
 6.1 INPUT SIGNAL TIMING SPECIFICATIONS 25

CONFIDENTIAL

6.1. 1	Timing spec for QFHD Frame Rate = 50Hz	25
6.1. 2	Timing spec for QFHD Frame Rate = 60Hz	25
6.1.3	Input Timing Spec for FHD, Frame Rate = 50Hz.....	26
6.1.4	Input Timing Spec for FHD, Frame Rate = 60Hz.....	26
6.1.5	Input Timing Spec for FHD, Frame Rate = 100Hz.....	27
6.1.6	Input Timing Spec for FHD, Frame Rate = 120Hz.....	27
6.1.7	Input Timing spec for QFHD, Frame Rate = 24Hz.....	28
6.1.8	Input Timing spec for QFHD, Frame Rate = 30Hz.....	28
6.2	V by One Input Signal Timing Diagram	31
6.3	Byte Length and Color mapping of V-by-One HS.....	31
6.4	POWER ON/OFF SEQUENCE	33
6.5	2D/3D MODE CHANGE SIGNAL SEQUENCE WITHOUT VCC TURN OFF AND TURN ON.....	34
7.	OPTICAL CHARACTERISTICS	35
7.1	TEST CONDITIONS	35
7.2	OPTICAL SPECIFICATIONS	36
8.	PRECAUTIONS	41
8.1	ASSEMBLY AND HANDLING PRECAUTIONS.....	41
8.2	SAFETY PRECAUTIONS	41
8.3	SAFETY STANDARDS	41
9.	DEFINITION OF LABELS	42
9.1	MODULE LABEL	42
9.2	CARTON LABEL.....	43
10.	PACKAGING.....	44
10.1	PACKAGING SPECIFICATIONS	44
10.2	PACKAGING METHOD.....	44
10.3	UN-PACKAGING METHOD	45
11.	MECHANICAL CHARACTERISTIC	46

CONFIDENTIAL

REVISION HISTORY

Version	Date	Page (New)	Section	Description
0.0	Aug.1.2013	All	All	Tentative Specification Ver 0.0 was first issued.
1.0	Aug.21.2013	16	4.1	Modify TFT LCD MODULE
		17	5.1	Modify TFT LCD MODULE
		25	6.1.1	Modify Timing spec for QFHD Frame Rate = 50Hz
		25	6.1.2	Modify Timing spec for QFHD Frame Rate = 60Hz
		26	6.1.3	Modify Input Timing Spec for FHD, Frame Rate = 50Hz
		26	6.1.4	Modify Input Timing Spec for FHD, Frame Rate = 60Hz
		26-27	6.1.5	Modify Input Timing Spec for FHD, Frame Rate = 100Hz
		27	6.1.6	Modify Input Timing Spec for FHD, Frame Rate = 120Hz
		27-28	6.1.7	Modify Input Timing spec for QFHD, Frame Rate = 24Hz
		28	6.1.8	Modify Input Timing spec for QFHD, Frame Rate = 30Hz
		36	7.2	Modify OPTICAL SPECIFICATIONS
		44-45	10.2	Modify PACKAGING METHOD
		45	10.3	Modify UN-PACKAGING METHOD
2.0	Sep.24.2013	5	1.3	Modify GENERAL SPECIFICATIONS
		8	3.1	Modify TFT LCD MODULE
		12	3.2.1	Modify CONVERTER CHARACTERISTICS
		16	4.1	Modify TFT LCD MODULE
		17-19	5.1	Modify TFT LCD MODULE
		25-28	6.1	Modify INPUT SIGNAL TIMING SPECIFICATIONS
		33	6.4	Modify POWER ON/OFF SEQUENCE
		34	6.5	Modify 2D/3D MODE CHANGE SIGNAL SEQUENCE WITHOUT VCC TURN OFF AND TURN ON
		45	11	Modify MECHANICAL CHARACTERISTIC
		43	10.1	Modify PACKAGING SPECIFICATIONS

CONFIDENTIAL

1. GENERAL DESCRIPTION

1.1 OVERVIEW

USMP-V500DK2-KS1 is a 50" TFT Liquid Crystal Display module with LED Backlight unit and 8Lanes **V-by-One HS** interface. This module supports 3840 x 2160 Quad Full HDTV format and can display true 1.07G colors (8-bit+FRC). The driving board module for backlight is built-in.

1.2 FEATURES

- High brightness 400 nits
- High contrast ratio 4000:1
- Fast response time Gray to Gray typical : 9.5 ms
- High color saturation NTSC 72%
- Quad Full HDTV (3840 x 2160 pixels) resolution, true HDTV format
- V-by-One HS interface
- Optimized response time for 50Hz/60Hz frame rate
- Viewing Angle : 176(H)/176(V) (CR>20) VA Technology
- Ultra wide viewing angle: Super MVA technology
- RoHs compliance
- T-con input frame rate : FHD 50/60Hz, FHD 100/120Hz, QFHD 24/30Hz or QFHD 50/60Hz,
Output frame rate: QFHD 50/60Hz, QFHD 100/120Hz

*: The detail setting such as I2C command or timing requirement in FHD/QFHD is specified in INX application note. It's important and necessary to follow the specification either in product SPEC or application note, otherwise it may lead to abnormal or no display. INX application note would be provided by INX in the design-in stage.

1.3 GENERAL SPECIFICATIONS

Item	Specification	Unit	Note
Active Area	1095.84(H) x 616.41(V) (50" diagonal)	mm	(1)
Bezel Opening Area	1103.04(H) x 622.41(V)	mm	
Driver Element	a-si TFT active matrix	-	-
Pixel Number	3840 x R.G.B. x 2160	pixel	-
Pixel Pitch(Sub Pixel)	0.0955(H) x 0.2865(V)	mm	-
Pixel Arrangement	RGB vertical stripe	-	-
Display Colors	1.07G colors (8-bit+FRC)	color	-
Display Operation Mode	Transmissive mode / Normally black	-	-
Surface Treatment	Anti-Glare coating (Haze 1%) · Hardness 3H	-	(2)
Rotation Function	Unachievable		(3)
Display Orientation	Signal input with "INX"		(3)

Note (1) Please refer to the attached drawings in chapter 11 for more information about the front and back outlines.

Note (2) The spec of the surface treatment is temporarily for this phase. INX reserves the rights to change this feature.

Note (3)

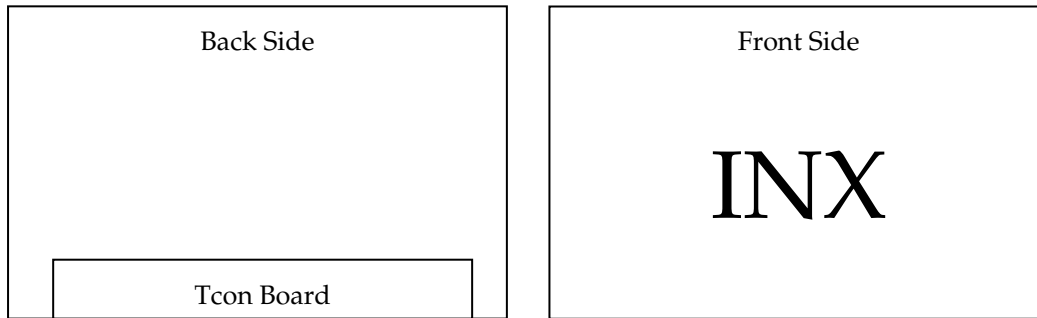

1.4 MECHANICAL SPECIFICATIONS

Item		Min.	Typ.	Max.	Unit	Note
Module Size	Horizontal (H)	1113.84	1115.04	1116.24	mm	(1),(2)
	Vertical (V)	637.21	638.41	639.61	mm	(1),(2)
	Depth (D)	15.2	16.2	17.2	mm	To Rear
		26.6	27.6	28.6	mm	To converter cover
Weight		11144	11730	12316	g	

Note (1) Please refer to the attached drawings for more information of front and back outline dimensions.

Note (2) Module Depth does not include connectors.

CONFIDENTIAL

2. ABSOLUTE MAXIMUM RATINGS

2.1 ABSOLUTE RATINGS OF ENVIRONMENT

Item	Symbol	Value		Unit	Note
		Min.	Max.		
Storage Temperature	T _{ST}	-20	+60	°C	(1)
Operating Ambient Temperature	T _{OP}	0	50	°C	(1), (2)
Shock (Non-Operating)	S _{NOF}	-	35	G	(3), (5)
Vibration (Non-Operating)	V _{NOF}	-	1.0	G	(4), (5)

Note (1) Temperature and relative humidity range is shown in the figure below.

- (a) 90 %RH Max. (Ta ≤ 40 °C).
- (b) Wet-bulb temperature should be 39 °C Max. (Ta > 40 °C).
- (c) No condensation.

Note (2) Thermal management should be considered in final product design to prevent the surface temperature of display area from being over 65 °C. The range of operating temperature may degrade in case of improper thermal management in final product design.

Note (3) 11 ms, half sine wave, 1 time for ± X, ± Y, ± Z.

Note (4) 10 ~ 200 Hz, 30 min, 1 time each X, Y, Z.

Note (5) At testing Vibration and Shock, the fixture in holding the module has to be hard and rigid enough so that the module would not be twisted or bent by the fixture.

CONFIDENTIAL

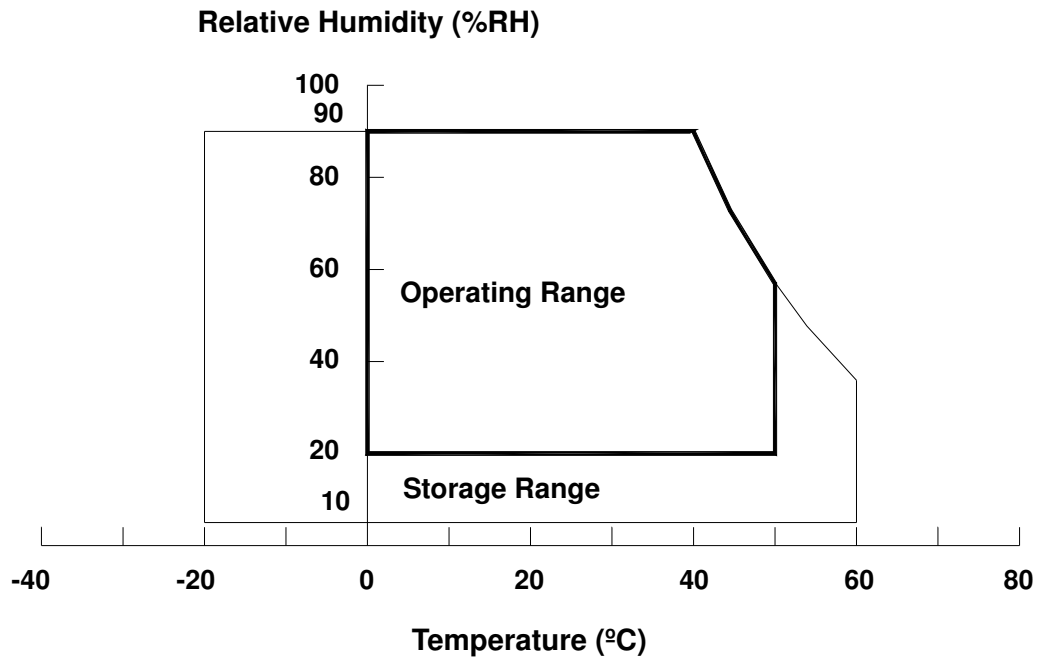

2.2 PACKAGE STORAGE

When storing modules as spares for a long time, the following precaution is necessary.

- (a) Do not leave the module in high temperature, and high humidity for a long time, It is highly recommended to store the module with temperature from 0 to 35 °C at normal humidity without condensation.
- (b) The module shall be stored in dark place. Do not store the TFT-LCD module in direct sunlight or fluorescent light.

2.3 ELECTRICAL ABSOLUTE RATINGS
2.3.1 TFT LCD MODULE

Item	Symbol	Value		Unit	Note
		Min.	Max.		
Power Supply Voltage	V _{CC}	-0.3	13.5	V	(1)
Logic Input Voltage	V _{IN}	-0.3	3.6	V	

2.3.2 BACKLIGHT CONVERTER UNIT

Item	Symbol	Test Condition	Min.	Type	Max.	Unit	Note
Light Bar Voltage	V _W	Ta = 25 °C	-	-	60	V _{RMS}	3D Mode
Converter Input Voltage	V _{BL}	-	0	-	30	V	
Control Signal Level	-	-	-0.3	-	6	V	

Note (1) Permanent damage to the device may occur if maximum values are exceeded. Function operation should be restricted to the conditions described under Normal Operating Conditions.

Note (2) No moisture condensation or freezing.

Note (3) The control signals include On/Off Control and External PWM Control.

3. ELECTRICAL CHARACTERISTICS
3.1 TFT LCD MODULE

(Ta = 25 ± 2 °C)

Parameter		Symbol	Value			Unit	Note
			Min.	Typ.	Max.		
Power Supply Voltage		V _{CC}	10.8	12	13.2	V	(1)
Rush Current		I _{RUSH}	—	—	3.4	A	(2)
OFHD 120Hz Output Power Consumption	White Pattern	P _T	—	17.28	20.76	W	(3)
	Horizontal Stripe	P _T	—	25.68	31.2	W	
	Black Pattern	P _T	—	17.16	20.64	W	
OFHD 120Hz Output Power Supply Current	White Pattern	—	—	1.44	1.73	A	
	Horizontal Stripe	—	—	2.14	2.6	A	
	Black Pattern	—	—	1.43	1.72	A	
QFHD 60Hz Output Power Consumption	White Pattern	P _T	—	12.24	14.88	W	
	Horizontal Stripe	P _T	—	26.52	31.68	W	
	Black Pattern	P _T	—	12.36	15	W	
QFHD 60Hz Output Power Supply Current	White Pattern	—	—	1.02	1.24	A	
	Horizontal Stripe	—	—	2.21	2.64	A	
	Black Pattern	—	—	1.03	1.25	A	
V-by-One HS	Differential Input High Threshold Voltage	VLVTH	—	—	+50	mV	(4)
	Differential Input Low Threshold Voltage	VLVTL	-50	—	—	mV	
	Differential input voltage (single-end)	VID	200	—	600	mV	
CMOS interface	Input High Threshold Voltage	V _{IH}	2.7	—	3.6	V	
	Input Low Threshold Voltage	V _{IL}	0	—	0.7	V	

CONFIDENTIAL

Note (1) The module should be always operated within the above ranges. The ripple voltage should be controlled under 10% of Vcc (Typ.)

Note (2) Measurement condition :

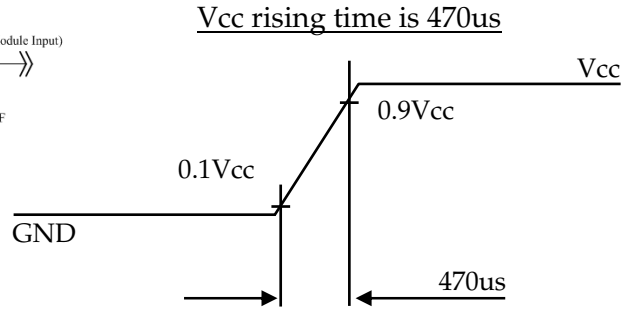
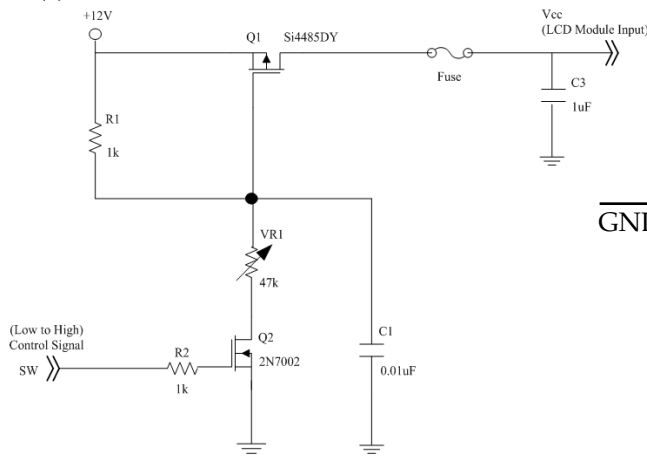

Note (3) The specified power supply current is under the conditions at Vcc = 12 V, Ta = 25 ± 2 °C, fv = 60/120 Hz, whereas a power dissipation check pattern below is displayed.

a. White Pattern

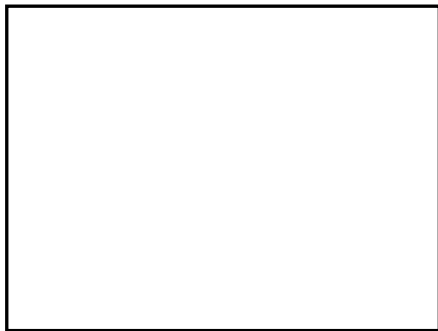

Active Area

b. Black Pattern



Active Area

c. Heavy Loading pattern

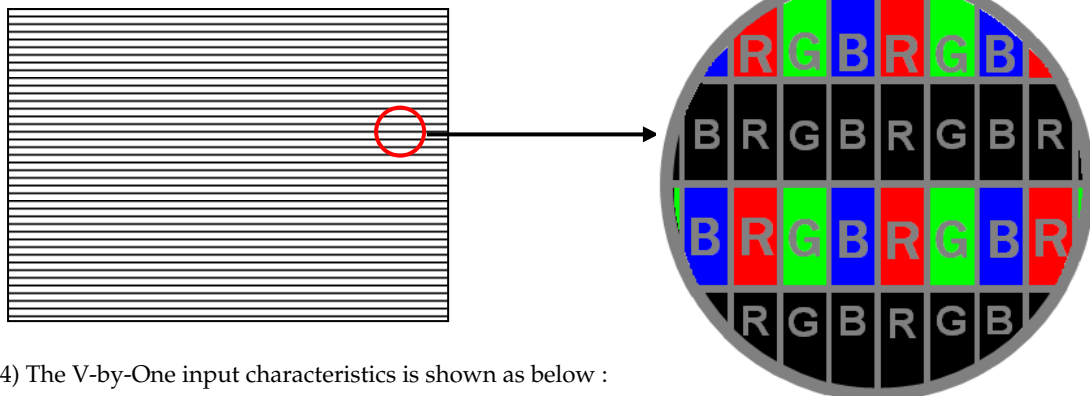

Note (4) The V-by-One input characteristics is shown as below :

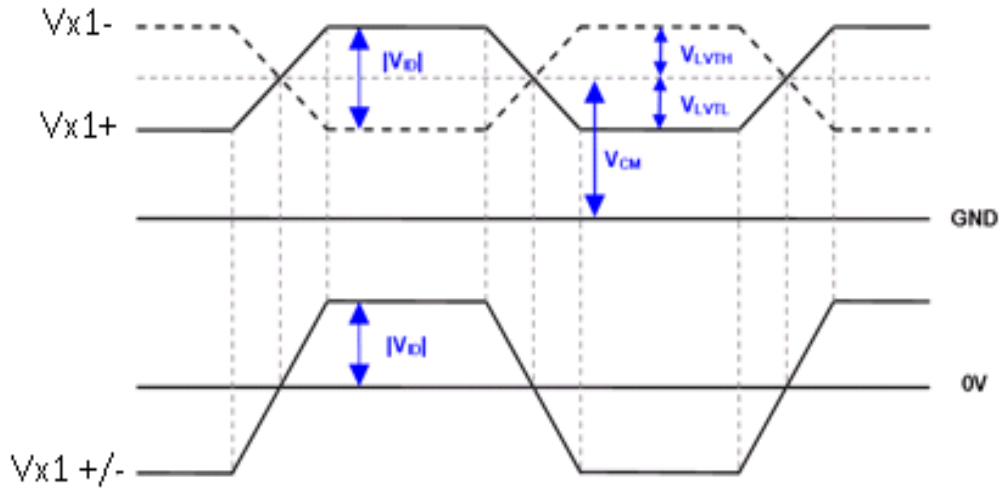

CONFIDENTIAL

3.2 BACKLIGHT UNIT
3.2.1 CONVERTER CHARACTERISTICS

Parameter	Symbol	Value			Unit	Note
		Min.	Typ.	Max.		
Power Consumption	$P_{BL(2D)}$	—	79.2	91.1	W	(1), (2)
	$P_{BL(3D)}$	—	76.5	86.43	W	(1), (2)
Converter Input Voltage	VBL	22.8	24.0	25.2	VDC	
Converter Input Current	$I_{BL(2D)}$	—	3.3	3.8	A	Non Dimming
	$I_{BL(3D)}$	—	3.2	3.6	A	
Input Inrush Current	$I_{R(2D)}$	—	—	9.5	Apeak	$V_{BL}=22.8V$ (3), (6)
	$I_{R(3D)}$	—	—	14	Apeak	$V_{BL}=22.8V$ (3), (6)
Dimming Frequency	FB	170	180	190	Hz	(5)
Dimming Duty Ratio	DDR	0	-	100	%	(4), (5)
Life Time	-	30,000	-	-	Hrs	(7)

Note (1) The power supply capacity should be higher than the total converter power consumption P_{BL} . Since the pulse width modulation (PWM) mode was applied for backlight dimming, the driving current changed as PWM duty on and off. The transient response of power supply should be considered for the changing loading when converter dimming.

Note (2) The measurement condition of Max. value is based on 58" backlight unit under input voltage 24V, at 2D/3D Mode and lighting 1 hour later.

Note (3) For input inrush current measure, the VBL rising time from 10% to 90% is about 20ms.

Note (4) EPWM signal have to input available duty range. Between 97% and 100% duty (DDR) have to be avoided. (97% < DDR < 100%) But 100% duty (DDR) is possible. 5% duty (DDR) is only valid for electrical operation.

Note (5) FB and DDR are available only at 2D Mode.

Note (6) Below diagram is only for power supply design reference.

CONFIDENTIAL

Test Condition: VBL=22.8V, IL=105mA at 2D Mode/IL=(400)mApeak at 3D Mode.

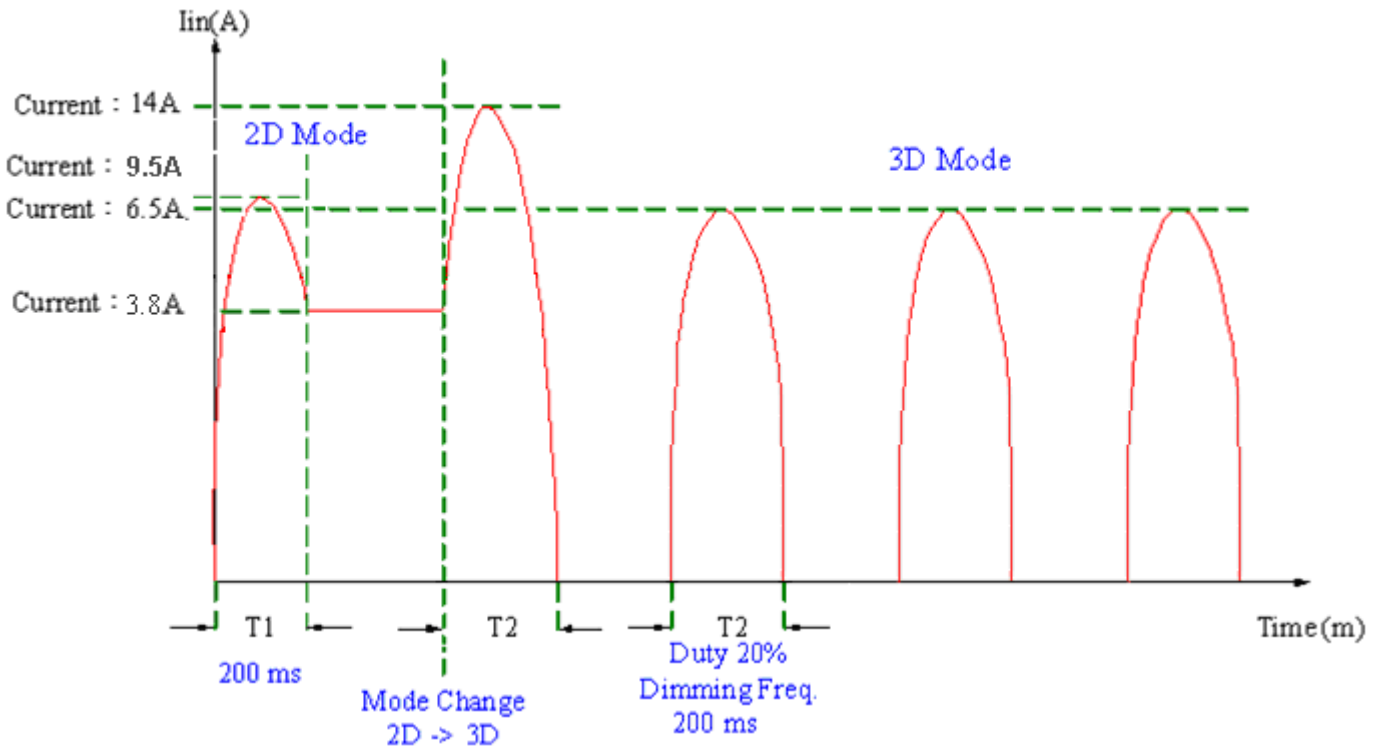

Note (7) The lifetime is defined as the time which luminance of the LED decays to 50% compared to the initial value,
Operating condition: Continuous operating at $T_a = 25 \pm 2^\circ C$

CONFIDENTIAL

3.2.2 CONVERTER INTERFACE CHARACTERISTICS

Parameter	Symbol	Test Condition	Value			Unit	Note		
			Min.	Typ.	Max.				
On/Off Control Voltage	ON	VBLON	—	2.0	—	5.0	V		
	OFF		—	0	—	0.8	V		
External PWM Control Voltage	HI	VEPWM	—	2.0	—	5.25	V	Duty on	(5), (6)
	LO		—	0	—	0.8	V	Duty off	
External PWM Frequency	F _{EPWM}	—	150	160	170	Hz	Normal mode (7)		
Error Signal	ERR	—	—	—	—	—	Abnormal: Open		
VBL Rising Time	Tr1	—	20	—	—	ms	10%-90%V _{BL}		
Control Signal Rising Time	Tr	—	—	—	100	ms			
Control Signal Falling Time	Tf	—	—	—	100	ms			
PWM Signal Rising Time	TPWMR	—	—	—	50	us	(6)		
PWM Signal Falling Time	TPWMF	—	—	—	50	us			
Input Impedance	Rin	—	1	—	—	MΩ	EPWM, BLON		
PWM Delay Time	TPWM	—	100	—	—	ms	(6)		
BLON Delay Time	T _{on}	—	300	—	—	ms			
	T _{on1}	—	300	—	—	ms			
BLON Off Time	Toff	—	300	—	—	ms			

Note (1) The Dimming signal should be valid before backlight turns on by BLON signal. It is inhibited to change the external PWM signal during backlight turn on period.

Note (2) The power sequence and control signal timing are shown in the Fig.1. For a certain reason, the converter has a possibility to be damaged with wrong power sequence and control signal timing.

Note (3) While system is turned ON or OFF, the power sequences must follow as below descriptions:

Turn ON sequence: VBL → PWM signal → BLON

Turn OFF sequence: BLOFF → PWM signal → VBL

Note (4) When converter protective function is triggered, ERR will output open collector status. Please refers to Fig.2.

Note (5) The EPWM interface that inserts a pull up resistor to 5V in Max Duty (100%), please refers to Fig.3.

Note (6) EPWM is available only at 2D Mode.

Note (7) EPWM signal have to input available frequency range.

Note (8) [Recommend] EPWM duty ratio is set at 100%(Max. Brightness) in 3D Mode.

Note (9) Used the EPWM signal control user dimming only in 2D normal Mode. 2D scan and 2D local dimming Mode please reference 5.1 Note (11) and application Note.

CONFIDENTIAL

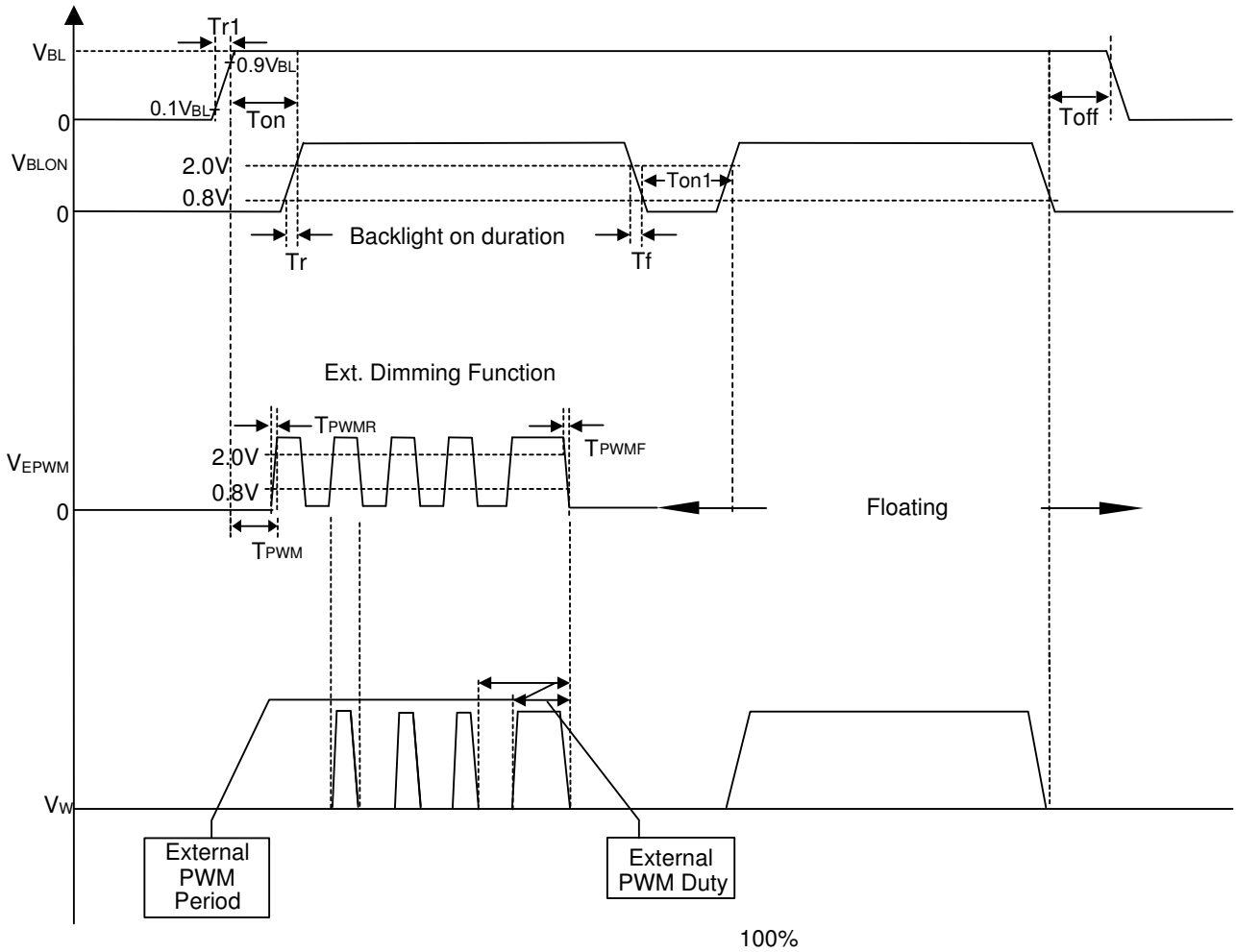

Fig. 1

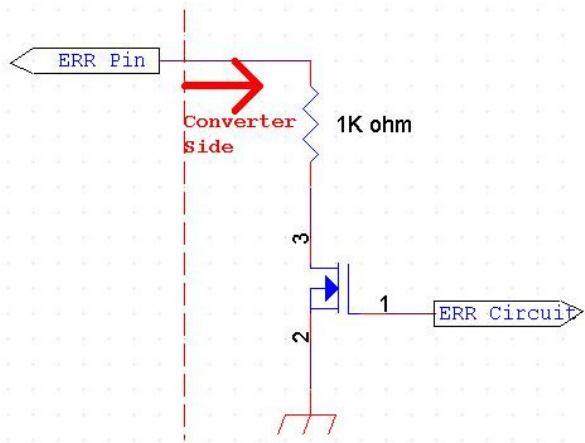

Fig. 2

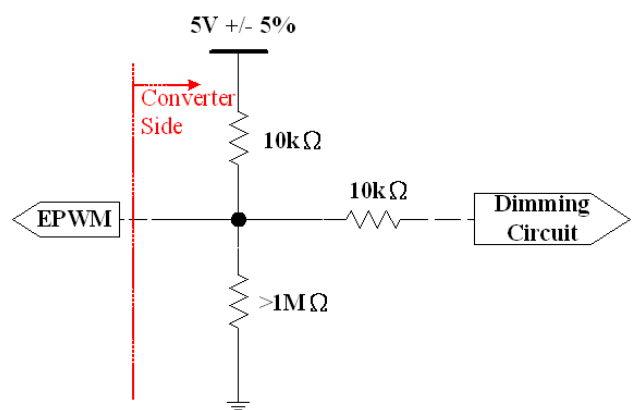
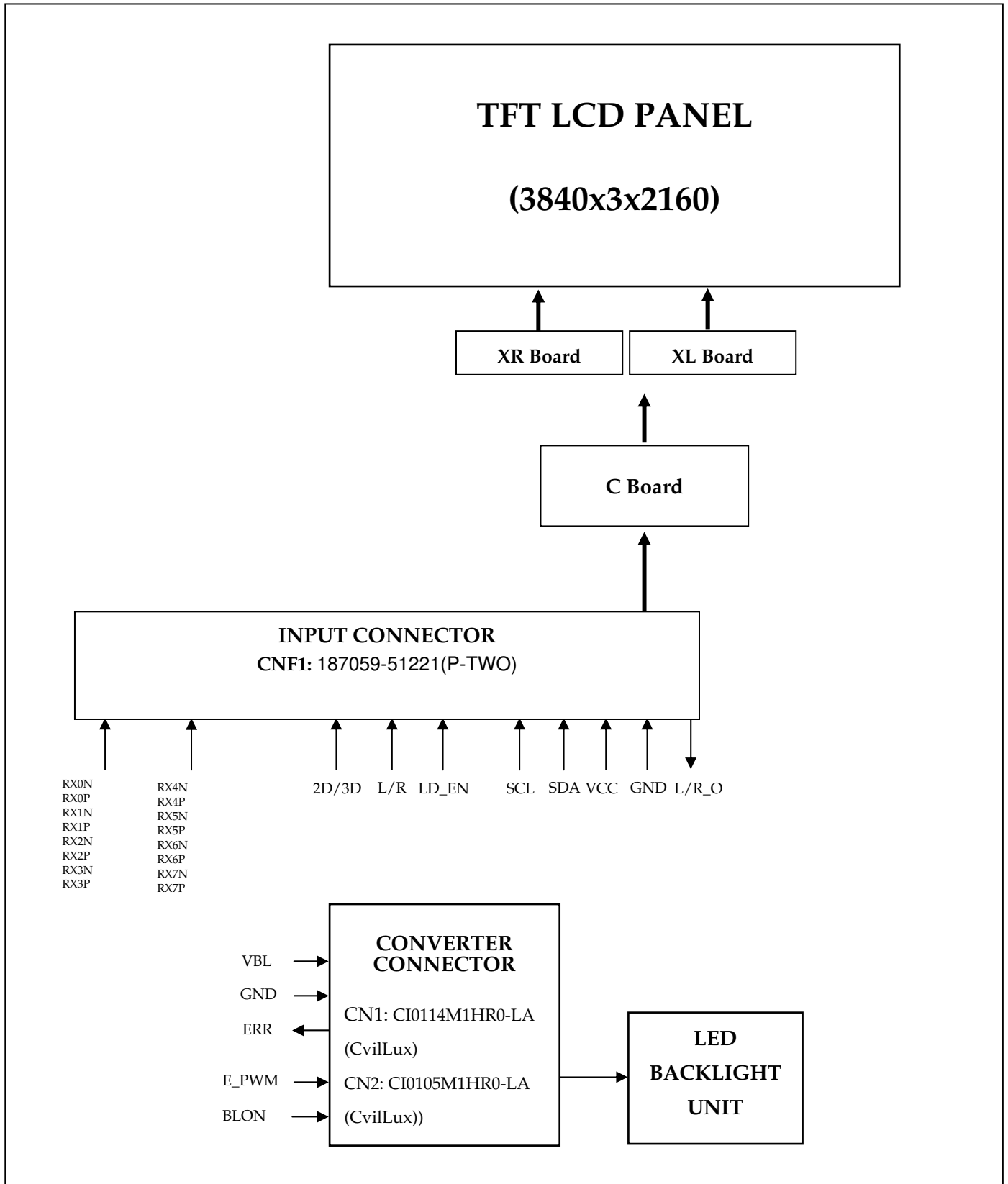

Fig. 3

4. BLOCK DIAGRAM OF INTERFACE

4.1 TFT LCD MODULE



CONFIDENTIAL

5 .INPUT TERMINAL PIN ASSIGNMENT
5.1 TFT LCD MODULE

CNV1 Connector Pin Assignment (187059-51221(P-TWO))

Pin	Name	Description	Note
1	Vin	Power input (+12V)	
2	Vin	Power input (+12V)	
3	Vin	Power input (+12V)	
4	Vin	Power input (+12V)	
5	Vin	Power input (+12V)	
6	Vin	Power input (+12V)	
7	Vin	Power input (+12V)	
8	Vin	Power input (+12V)	
9	N.C.	No Connection	(10)
10	GND	Ground	
11	GND	Ground	
12	GND	Ground	
13	GND	Ground	
14	GND	Ground	
15	L/R_O	Output signal for Glasses Left Right signal,	(5)
16	L/R	Input signal for Left/Right synchronous signal.	(3) (7)
17	2D/3D	2D/3D Enable	(2) (7)
18	SDA	I2C Data signal	(11)(12)
19	SCL	I2C Clock signal	(11)(12)
20	N.C.	No Connection	
21	N.C.	No Connection	(10)
22	LD_EN	Local Dimming Mode Enable.	(4) (6)
23	N.C.	No Connection	(10)
24	N.C.	No Connection	(10)
25	HTPDN	Hot plug detect output, Open drain.	
26	LOCKN	Lock detect output, Open drain.	
27	GND	Ground	
28	RX0N	1 ST Pixel Negative V-by-One differential data input in area A. Lane 0	(1)
29	RX0P	1 ST Pixel Positive V-by-One differential data input in area A. Lane 0	
30	GND	Ground	
31	RX1N	2 ND Pixel Negative V-by-One differential data input in area A. Lane 1	(1)
32	RX1P	2 ND Pixel Positive V-by-One differential data input in area A. Lane 1	
33	GND	Ground	

CONFIDENTIAL

PRODUCT SPECIFICATION

34	RX2N	3 RD Pixel Negative V-by-One differential data input in area A. Lane 2	(1)
35	RX2P	3 RD Pixel Positive V-by-One differential data input in area A. Lane 2	
36	GND	Ground	
37	RX3N	4 TH Pixel Negative V-by-One differential data input in area A. Lane 3	(1)
38	RX3P	4 TH Pixel Positive V-by-One differential data input in area A. Lane 3	
39	GND	Ground	
40	RX4N	5 TH Pixel Negative V-by-One differential data input in area A. Lane 4	(1)
41	RX4P	5 TH Pixel Positive V-by-One differential data input in area A. Lane 4	
42	GND	Ground	
43	RX5N	6 TH Pixel Negative V-by-One differential data input in area A. Lane 5	(1)
44	RX5P	6 TH Pixel Positive V-by-One differential data input in area A. Lane 5	
45	GND	Ground	
46	RX6N	7 TH Pixel Negative V-by-One differential data input in area A. Lane 6	(1)
47	RX6P	7 TH Pixel Positive V-by-One differential data input in area A. Lane 6	
48	GND	Ground	
49	RX7N	8 TH Pixel Negative V-by-One differential data input in area A. Lane 7	(1)
50	RX7P	8 TH Pixel Positive V-by-One differential data input in area A. Lane 7	
51	GND	Ground	

Note (1) V-by-One^R HS Data Mapping

Area	Lane	Data Stream
A	Lane 0	1, 9, 17,, 3825, 3833
	Lane 1	2, 10, 18,, 3826, 3834
	Lane 2	3, 11, 19,, 3827, 3835
	Lane 3	4, 12, 20,, 3828, 3836
	Lane 4	5, 13, 21,, 3829, 3837
	Lane 5	6, 14, 22,, 3830, 3838
	Lane 6	7, 15, 23,, 3831, 3839
	Lane 7	8, 16, 24,, 3832, 3840

CONFIDENTIAL

PRODUCT SPECIFICATION

Front View

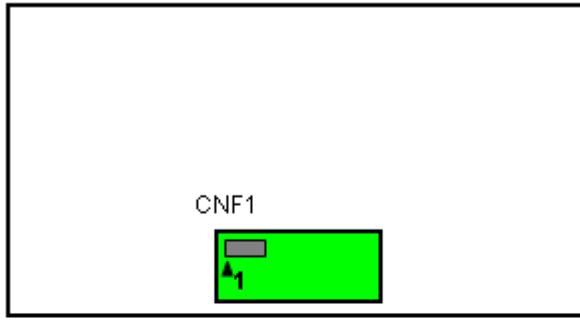

Data Lane 0	A
Data Lane 1	
Data Lane 2	
Data Lane 3	
Data Lane 4	
Data Lane 5	
Data Lane 6	
Data Lane 7	

Display



Pixel Arrangement

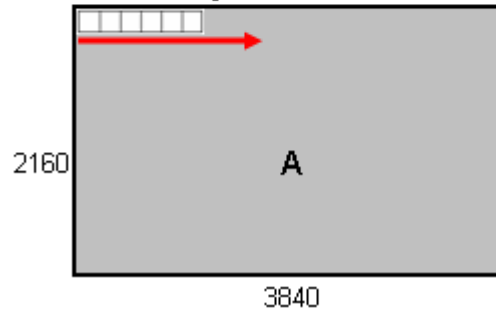

Note (2) 2D/3D mode selection.

L= Connect to GND or Open, H=Connect to +3.3V

2D/3D	Note
L or Open	2D Mode
H	3D Mode

Note (3) Input signal for Left Right eye frame synchronous

$V_{IL}=0\sim 0.8\text{ V}$, $V_{IH}=2.0\sim 3.3\text{ V}$

L/R	Note
L	Right synchronous signal
H	Left synchronous signal

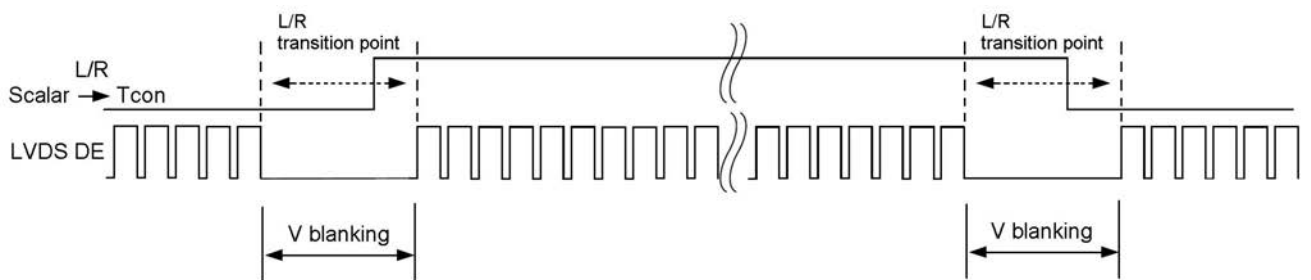

Note (4) Local dimming enable selection. (Default: enable)

L= Connect to GND, H=Connect to +3.3V or Open

LD_EN	Note
L	Local Dimming Disable
H or Open	Local Dimming Enable

LD_EN enable pin should be set in power on stage.

CONFIDENTIAL

Backlight should be turned off in the period of changing original setting after power on.

Note (5) The definition of L/R_O signal as follows

L= 0V , H= +3.3V

L/R_O	Note
L	Right glass turn on
H	Left glass turn on

Note (6) Interface optional pin has internal scheme as following diagram. Customer should keep the interface voltage level requirement which including Panel board loading as below.

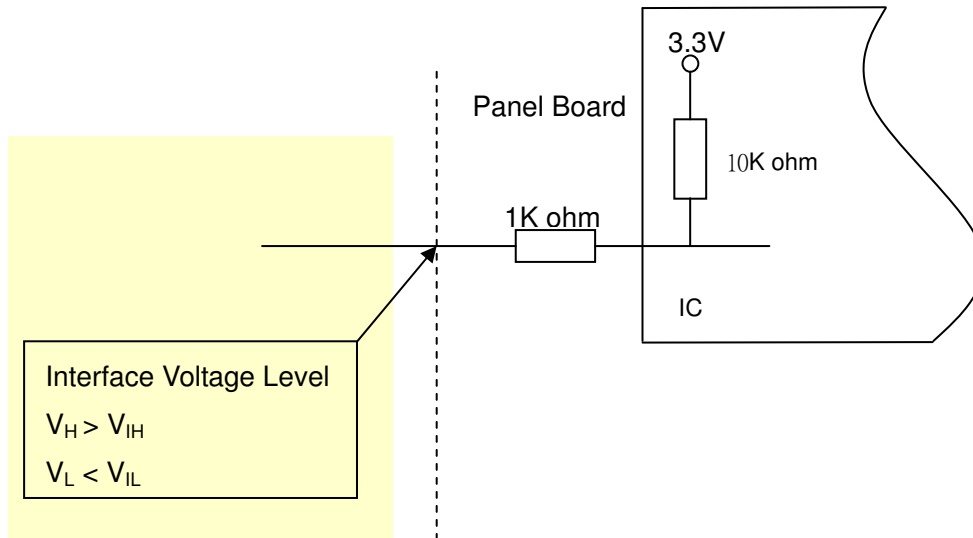

Note (7) Interface optional pin has internal scheme as following diagram. Customer should keep the interface voltage level requirement which including Panel board loading as below.

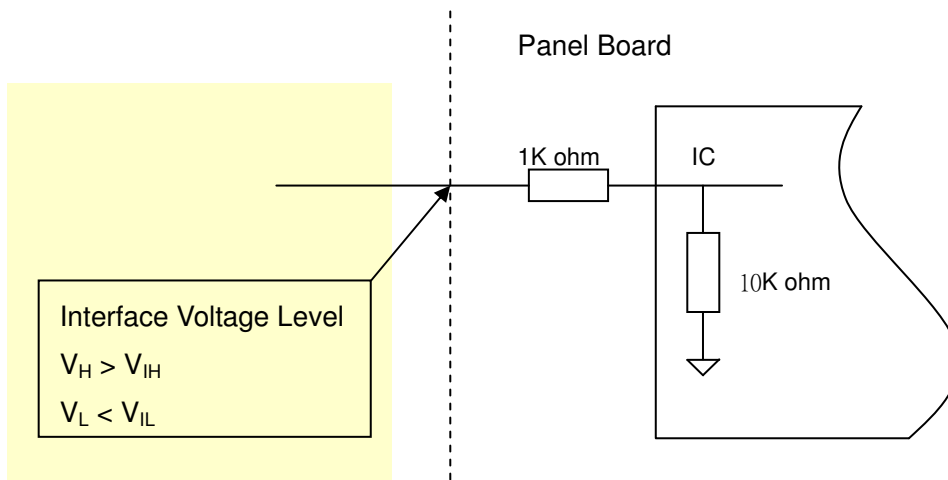

Note (8) V-by-One HS connector pin order defined as follows

CONFIDENTIAL

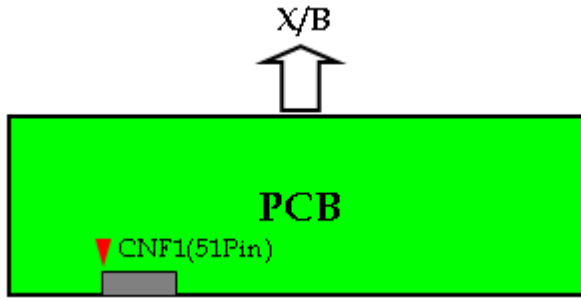

Note (9) V-by-One connector mating dimension range request is 0.93mm~1.0mm as below

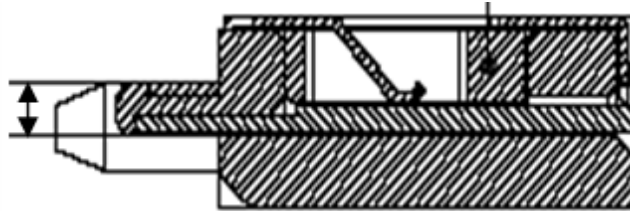

Note (10) Reserved for internal use. Please leave it open.

Note (11) Local dimming table select & User dimming adjust for customer use. (User dimming is available only at 2D Mode.

User dimming duty ratio is set at 100% (Max. Brightness) in 3D Mode.)

Note (12) The detail setting such as I2C command or timing requirement in FHD/QFHD is specified in INX application note. It's important and necessary to follow the specification either in product SPEC or application note, otherwise it may lead to abnormal or no display. INX application note would be provided by INX in the design-in stage.

5.2 BACKLIGHT UNIT

The pin configuration for the housing and leader wire is shown in the table below.

CN3

Connector Type : 196388-12041-3(P-TWO) or FF01-431-123A(FCN)

Pin No.	Symbol	Description
1	VLED+	Positive of LED string
2	VLED+	
3	VLED+	
4	NC	NC
5	N-	Negative of LED string
6	N-	
7	N-	
8	N-	
9	N-	
10	N-	
11	N-	
12	N-	

CN6

Connector Type : 196388-12041-3(P-TWO) or FF01-431-123A(FCN)

Pin No.	Symbol	Description
1	N-	Negative of LED string
2	N-	
3	N-	
4	N-	
5	N-	
6	N-	
7	N-	
8	N-	
9	NC	NC
10	VLED+	Positive of LED string
11	VLED+	
12	VLED+	

5.3 CONVERTER UNIT

CN1 (Header) : CI0114M1HR0-LA (CvilLux)

Pin No.	Symbol	Feature
1	VBL	+24V
2		
3		
4		
5		
6	GND	GND
7		
8		
9		
10		
11	ERR	Normal (GND) ; Abnormal (Open collector)
12	BLON	BL ON/OFF
13	NC	NC
14	E_PWM	External PWM Control

Note (1) If Pin14 is open, E_PWM is 100% duty.

Note (2) Input connector pin order defined as follows

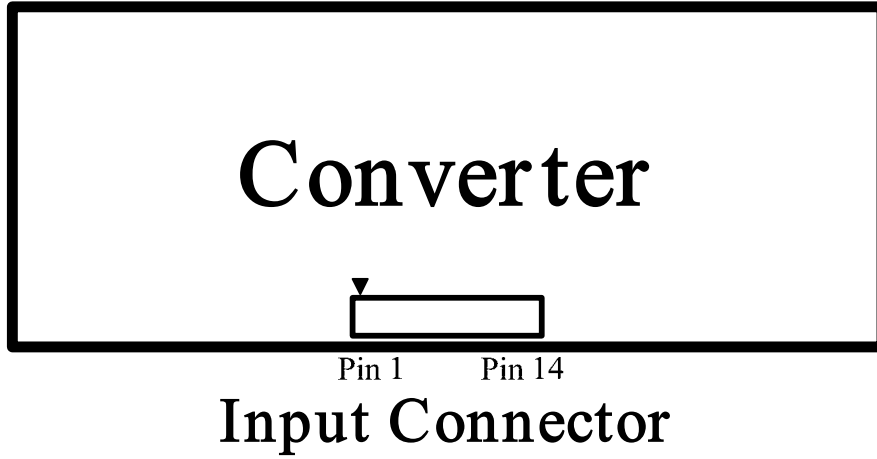

CONFIDENTIAL

5.4 COLOR DATA INPUT ASSIGNMENT

The brightness of each primary color (red, green and blue) is based on the 10-bit gray scale data input for the color. The higher the binary input the brighter the color. The table below provides the assignment of color versus data input.

Color		Data Signal																																						
		Red										Green										Blue																		
		R9	R8	R7	R6	R5	R4	R3	R2	R1	R0	G9	G8	G7	G6	G5	G4	G3	G2	G1	G0	B9	B8	B7	B6	B5	B4	B3	B2	B1	B0									
Basic Colors	Black	0	0	0	0	0	0	0	0	0	0	0	0	0	0	0	0	0	0	0	0	0	0	0	0	0	0	0	0	0	0	0	0	0	0	0	0	0	0	0
	Red	1	1	1	1	1	1	1	1	1	1	0	0	0	0	0	0	0	0	0	0	0	0	0	0	0	0	0	0	0	0	0	0	0	0	0	0	0	0	0
	Green	0	0	0	0	0	0	0	0	0	0	0	1	1	1	1	1	1	1	1	0	0	0	0	0	0	0	0	0	0	0	0	0	0	0	0	0	0	0	0
	Blue	0	0	0	0	0	0	0	0	0	0	0	0	0	0	0	0	0	0	0	0	0	0	0	0	0	0	0	0	0	1	1	1	1	1	1	1	1	1	1
	Cyan	0	0	0	0	0	0	0	0	0	0	0	1	1	1	1	1	1	1	1	1	1	1	1	1	1	1	1	1	1	0	0	0	0	0	0	0	0	0	0
	Magenta	1	1	1	1	1	1	1	1	1	1	0	0	0	0	0	0	0	0	0	0	0	0	0	0	0	0	0	0	0	1	1	1	1	1	1	1	1	1	1
	Yellow	1	1	1	1	1	1	1	1	1	1	1	1	1	1	1	1	1	1	1	1	1	1	1	1	1	1	1	1	1	0	0	0	0	0	0	0	0	0	0
	White	1	1	1	1	1	1	1	1	1	1	1	1	1	1	1	1	1	1	1	1	1	1	1	1	1	1	1	1	1	1	1	1	1	1	1	1	1	1	1
Gray Scale Of Red	Red (0) / Dark	0	0	0	0	0	0	0	0	0	0	0	0	0	0	0	0	0	0	0	0	0	0	0	0	0	0	0	0	0	0	0	0	0	0	0	0	0	0	
	Red (1)	0	0	0	0	0	0	0	0	0	1	0	0	0	0	0	0	0	0	0	0	0	0	0	0	0	0	0	0	0	0	0	0	0	0	0	0	0	0	
	Red (2)	0	0	0	0	0	0	0	0	1	0	0	0	0	0	0	0	0	0	0	0	0	0	0	0	0	0	0	0	0	0	0	0	0	0	0	0	0	0	
	:	:	:	:	:	:	:	:	:	:	:	:	:	:	:	:	:	:	:	:	:	:	:	:	:	:	:	:	:	:	:	:	:	:	:	:	:	:	:	
	:	:	:	:	:	:	:	:	:	:	:	:	:	:	:	:	:	:	:	:	:	:	:	:	:	:	:	:	:	:	:	:	:	:	:	:	:	:	:	
	:	:	:	:	:	:	:	:	:	:	:	:	:	:	:	:	:	:	:	:	:	:	:	:	:	:	:	:	:	:	:	:	:	:	:	:	:	:	:	
	Red (1021)	1	1	1	1	1	1	1	1	0	1	0	0	0	0	0	0	0	0	0	0	0	0	0	0	0	0	0	0	0	0	0	0	0	0	0	0	0	0	
	Red (1022)	1	1	1	1	1	1	1	1	1	0	0	0	0	0	0	0	0	0	0	0	0	0	0	0	0	0	0	0	0	0	0	0	0	0	0	0	0	0	
Red (1023)	1	1	1	1	1	1	1	1	1	1	0	0	0	0	0	0	0	0	0	0	0	0	0	0	0	0	0	0	0	0	0	0	0	0	0	0	0	0		
Gray Scale Of Green	Green (0) / Dark	0	0	0	0	0	0	0	0	0	0	0	0	0	0	0	0	0	0	0	0	0	0	0	0	0	0	0	0	0	0	0	0	0	0	0	0	0	0	
	Green (1)	0	0	0	0	0	0	0	0	0	0	0	0	0	0	0	0	0	0	0	0	0	0	0	0	0	0	0	0	1	0	0	0	0	0	0	0	0	0	
	Green (2)	0	0	0	0	0	0	0	0	0	0	0	0	0	0	0	0	0	0	0	0	0	0	0	0	0	0	0	0	0	0	0	0	0	0	0	0	0	0	
	:	:	:	:	:	:	:	:	:	:	:	:	:	:	:	:	:	:	:	:	:	:	:	:	:	:	:	:	:	:	:	:	:	:	:	:	:	:	:	
	:	:	:	:	:	:	:	:	:	:	:	:	:	:	:	:	:	:	:	:	:	:	:	:	:	:	:	:	:	:	:	:	:	:	:	:	:	:	:	
	:	:	:	:	:	:	:	:	:	:	:	:	:	:	:	:	:	:	:	:	:	:	:	:	:	:	:	:	:	:	:	:	:	:	:	:	:	:	:	
	Green (1021)	0	0	0	0	0	0	0	0	0	0	1	1	1	1	1	1	1	1	0	1	0	0	0	0	0	0	0	0	0	0	0	0	0	0	0	0	0	0	
	Green (1022)	0	0	0	0	0	0	0	0	0	0	1	1	1	1	1	1	1	1	0	0	0	0	0	0	0	0	0	0	0	0	0	0	0	0	0	0	0	0	
Green (1023)	0	0	0	0	0	0	0	0	0	0	1	1	1	1	1	1	1	1	0	0	0	0	0	0	0	0	0	0	0	0	0	0	0	0	0	0	0	0		
Gray Scale Of Blue	Blue (0) / Dark	0	0	0	0	0	0	0	0	0	0	0	0	0	0	0	0	0	0	0	0	0	0	0	0	0	0	0	0	0	0	0	0	0	0	0	0	0	0	
	Blue (1)	0	0	0	0	0	0	0	0	0	0	0	0	0	0	0	0	0	0	0	0	0	0	0	0	0	0	0	0	0	0	0	0	0	0	0	0	0	1	
	Blue (2)	0	0	0	0	0	0	0	0	0	0	0	0	0	0	0	0	0	0	0	0	0	0	0	0	0	0	0	0	0	0	0	0	0	0	0	0	0	1	
	:	:	:	:	:	:	:	:	:	:	:	:	:	:	:	:	:	:	:	:	:	:	:	:	:	:	:	:	:	:	:	:	:	:	:	:	:	:	:	
	:	:	:	:	:	:	:	:	:	:	:	:	:	:	:	:	:	:	:	:	:	:	:	:	:	:	:	:	:	:	:	:	:	:	:	:	:	:	:	
	:	:	:	:	:	:	:	:	:	:	:	:	:	:	:	:	:	:	:	:	:	:	:	:	:	:	:	:	:	:	:	:	:	:	:	:	:	:	:	
Blue (1021)	0	0	0	0	0	0	0	0	0	0	0	0	0	0	0	0	0	0	0	1	1	1	1	1	1	1	1	1	1	1	1	1	1	1	1	1	0	1		
Blue (1022)	0	0	0	0	0	0	0	0	0	0	0	0	0	0	0	0	0	0	0	1	1	1	1	1	1	1	1	1	1	1	1	1	1	1	1	1	1	0		
Blue (1023)	0	0	0	0	0	0	0	0	0	0	0	0	0	0	0	0	0	0	0	1	1	1	1	1	1	1	1	1	1	1	1	1	1	1	1	1	1	1		

Note (1) 0: Low Level Voltage , 1: High Level Voltage

CONFIDENTIAL

6. INTERFACE TIMING
6.1 INPUT SIGNAL TIMING SPECIFICATIONS

The input signal timing specifications are shown as the following table and timing diagram. (Ta = 25 ± 2 °C)

Signal	Item	Symbol	Min.	Typ.	Max.	Unit	Note
Frequency	Data Clock	1/Tc	70	74.25	78	MHz	(1)
V-by-One Receiver	Intra-Pair skew		-0.3	—	0.3	UI	(2)
	Inter-pair skew		-5	—	5	UI	(3)
	Spread spectrum modulation range	F _{elkin_mod}	1/Tc-0.5%	—	1/Tc+0.5%	MHz	(4)
	Spread spectrum modulation frequency	F _{SSM}	—	—	30	KHz	

6.1. 1 Timing spec for QFHD Frame Rate = 50Hz

Signal	Item	Symbol	Min.	Typ.	Max.	Unit	Note	
Data Clock	2D Mode	F _{elkin} (=1/TC)	70	74.25	78	MHz	(1)	
Frame Rate	2D Mode	F _r	57	60	63	Hz	(8),(9)	
Vertical Active Display Term (8 Lane,3840X2160 Active Area)	2D Mode	Total	Tv	2200	2700	2790	Th	Tv=Tvd+Tvb
		Display	Tvd	2160			Th	
		Blank	Tvb	40	540	630	Th	
Horizontal Active Display Term (8 Lane,3840X2160 Active Area)	2D Mode	Total	Th	530	550	600	Tc	Th=Thd+Thb
		Display	Thd	480			Tc	
		Blank	Thb	50	70	120	Tc	

6.1. 2 Timing spec for QFHD Frame Rate = 60Hz

Signal	Item	Symbol	Min.	Typ.	Max.	Unit	Note	
Data Clock	2D Mode	F _{elkin} (=1/TC)	70	74.25	78	MHz	(1)	
	3D Mode		74.25			MHz		
Frame Rate	2D Mode	F _r	57	60	63	Hz	(8),(9)	
	3D Mode		60			Hz	(6)	
Vertical Active Display Term	2D Mode	Total	Tv	2208	2250	2350	Th	Tv=Tvd+Tvb
		Display	Tvd	2160			Th	

(8 Lane,3840X2160 Active Area)	3D Mode	Blank	Tvb	48	90	190	Th	
		Total	Tv	2250			Th	
		Display	Tvd	2160			Th	(7)
		Blank	Tvb	90			Th	
Horizontal Active Display Term (8 Lane,3840X2160 Active Area)	2D Mode	Total	Th	530	550	600	Tc	Th=Thd+Thb
		Display	Thd	480			Tc	
		Blank	Thb	50	70	120	Tc	
	3D Mode	Total	Th	530	550	600	Tc	Th=Thd+Thb
		Display	Thd	480			Tc	
		Blank	Thb	50	70	120	Tc	

6.1.3 Input Timing Spec for FHD, Frame Rate = 50Hz

Signal	Item	Symbol	Min.	Typ.	Max.	Unit	Note	
Data Clock	Frequency	F_{clk} (=1/TC)	70	74.25	78	MHz	(1)	
Frame Rate	2D Mode	F_r	47	50	53	Hz	(8),(9)	
Vertical Active Display Term (2 Lane,1920X1080 Active Area)	2D Mode	Total	Tv	1104	1350	1395	Th	Tv=Tvd+Tvb
		Display	Tvd	1080			Th	
		Blank	Tvb	24	270	315	Th	
Horizontal Active Display Term (2 Lane,1920X1080 Active Area)		Total	Th	1060	1100	1340	Tc	Th=Thd+Thb
		Display	Thd	960			Tc	
		Blank	Thb	100	140	380	Tc	

6.1.4 Input Timing Spec for FHD, Frame Rate = 60Hz

Signal	Item	Symbol	Min.	Typ.	Max.	Unit	Note	
Data Clock	Frequency	F_{clk} (=1/TC)	70	74.25	78	MHz	(1)	
Frame Rate	2D Mode	F_r	57	60	63	Hz	(8),(9)	
Vertical Active Display Term (2 Lane,1920X1080 Active Area)	2D Mode	Total	Tv	1104	1125	1395	Th	Tv=Tvd+Tvb
		Display	Tvd	1080			Th	
		Blank	Tvb	24	45	315	Th	

Horizontal Active Display Term (2 Lane,1920X1080 Active Area)	Total	Th	1060	1100	1340	Tc	Th=Thd+Thb
	Display	Thd	960			Tc	
	Blank	Thb	100	140	380	Tc	

6.1.5 Input Timing Spec for FHD, Frame Rate = 100Hz

Signal	Item	Symbol	Min.	Typ.	Max.	Unit	Note	
Data Clock	Frequency	F_{clk} (=1/TC)	70	74.25	78	MHz	(1)	
Frame Rate	2D Mode	F_r	97	100	103	Hz	(8),(9)	
Vertical Active Display Term (4 Lane,1920X1080 Active Area)	2D Mode	Total	Tv	1104	1350	1395	Th	Tv=Tvd+Tvb
		Display	Tvd	1080			Th	
		Blank	Tvb	24	270	315	Th	
Horizontal Active Display Term (4 Lane,1920X1080 Active Area)	Mode	Total	Th	530	550	670	Tc	Th=Thd+Thb
		Display	Thd	480			Tc	
		Blank	Thb	50	70	190	Tc	

6.1.6 Input Timing Spec for FHD, Frame Rate = 120Hz

Signal	Item	Symbol	Min.	Typ.	Max.	Unit	Note	
Data Clock	2D Mode	F_{clk} (=1/TC)	70	74.25	78	MHz	(1)	
	3D Mode		74.25			MHz		
Frame Rate	2D Mode	F_r	117	120	123	Hz	(8),(9)	
	3D Mode		120			Hz	(6)	
Vertical Active Display Term (4 Lane,1920X1080 Active Area)	2D Mode	Total	Tv	1104	1125	1395	Th	Tv=Tvd+Tvb
		Display	Tvd	1080			Th	
		Blank	Tvb	24	45	315	Th	
	3D Mode	Total	Tv	1125			Th	(7)
		Display	Tvd	1080			Th	
		Blank	Tvb	45			Th	
Horizontal Active Display Term (4 Lane,1920X1080 Active Area)	2D Mode	Total	Th	530	550	670	Tc	Th=Thd+Thb
		Display	Thd	480			Tc	
		Blank	Thb	50	70	190	Tc	

Active Area)	3D Mode	Total	Th	530	550	670	Tc	Th=Thd+Thb
		Display	Thd	480			Tc	
		Blank	Thb	50	70	190	Tc	

6.1.7 Input Timing spec for QFHD, Frame Rate = 24Hz

Signal	Item	Symbol	Min.	Typ.	Max.	Unit	Note	
Data Clock	Frequency	F_{clk} (=1/TC)	70	74.25	78	MHz	(1)	
Frame Rate	2D Mode	F_r	23	24	25	Hz	(8),(9)	
Vertical Active Display Term (4 Lane,3840X2160 Active Area)	2D Mode	Total	Tv	2208	2250	2450	Th	Tv=Tvd+Tvb
		Display	Tvd	2160			Th	
		Blank	Tvb	48	90	290	Th	
Horizontal Active Display Term (4 Lane,3840X2160 Active Area)	2D Mode	Total	Th	1060	1100	1200	Tc	Th=Thd+Thb
		Display	Thd	960			Tc	
		Blank	Thb	80	140	240	Tc	

6.1.8 Input Timing spec for QFHD, Frame Rate = 30Hz

Signal	Item	Symbol	Min.	Typ.	Max.	Unit	Note	
Data Clock	2D Mode	F_{clk} (=1/TC)	70	74.25	78	MHz	(1)	
	3D Mode		74.25			MHz		
Frame Rate	2D Mode	F_r	29	30	31	Hz	(8),(9)	
	3D Mode		30			Hz	(6)	
Vertical Active Display Term (4 Lane,3840X2160 Active Area)	2D Mode	Total	Tv	2208	2250	2350	Th	Tv=Tvd+Tvb
		Display	Tvd	2160			Th	
		Blank	Tvb	48	90	190	Th	
	3D Mode	Total	Tv	2250			Th	(7)
		Display	Tvd	2160			Th	
		Blank	Tvb	90			Th	
Horizontal Active Display Term (4 Lane, 3840X2160 Active Area)	2D Mode	Total	Th	1060	1100	1200	Tc	Th=Thd+Thb
		Display	Thd	960			Tc	
		Blank	Thb	80	140	240	Tc	
	3D	Total	Th	1060	1100	1200	Tc	Th=Thd+Thb

	Mode	Display	Thd	960			Tc	
		Blank	Thb	1060	1100	1200	Tc	

Note (1) Please make sure the range of pixel clock has follow the below equation :

$$F_{clk}(max) \geq Fr \times Tv \times Th$$

$$Fr \times Tv \times Th \geq F_{clk}(min)$$

INPUT SIGNAL TIMING DIAGRAM

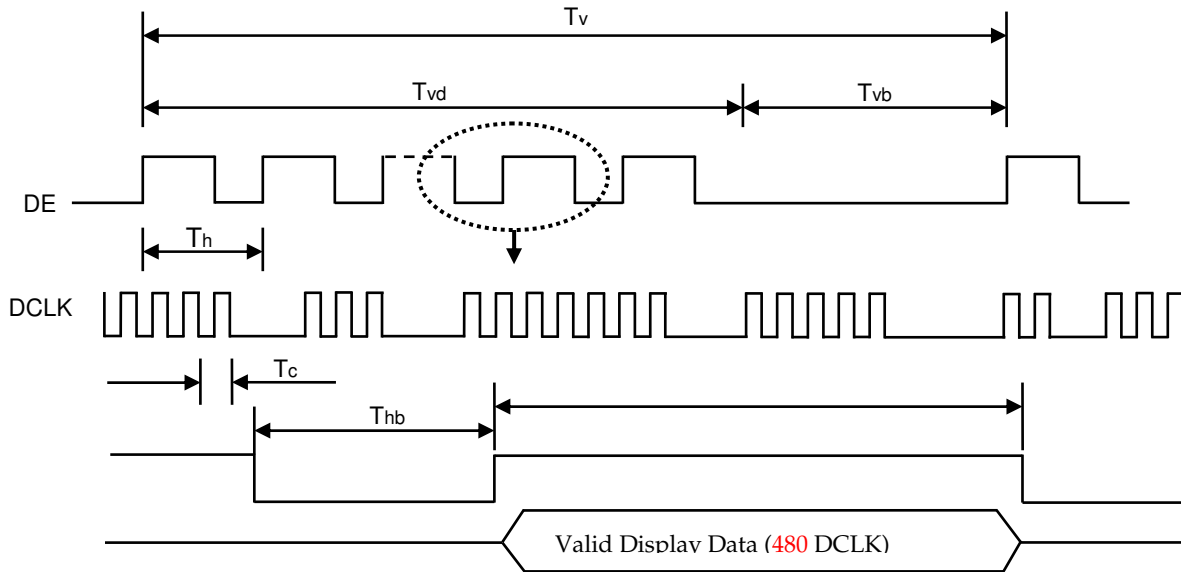

Note (2) Intra-pair Data skew

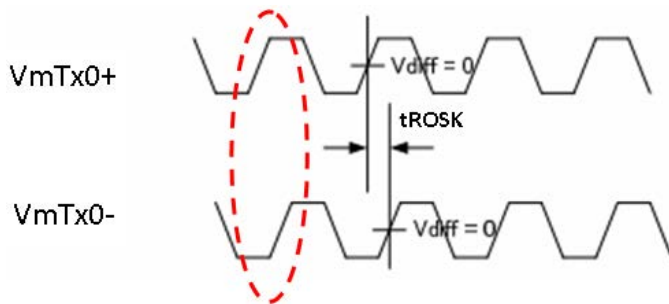

The same pair signal

Note (3) V-by-One HS Inter-pair skew.

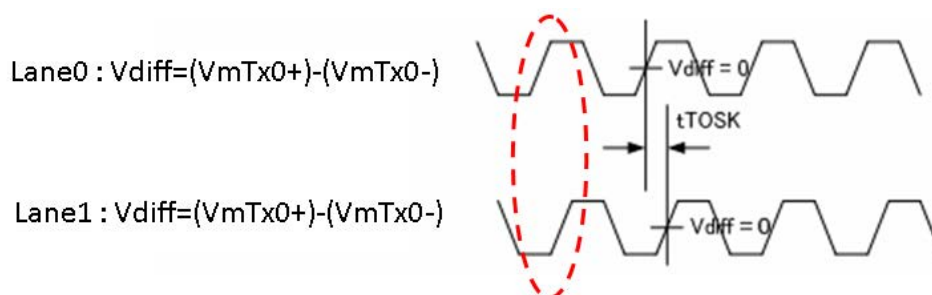

Different lanes

CONFIDENTIAL

Note (4) The SSCG (Spread spectrum clock generator) is defined as below figures.

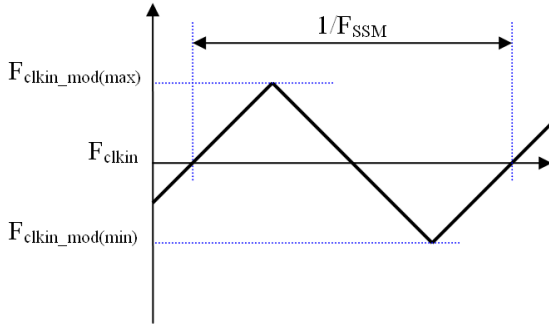

Note (5) Please fix the Vertical timing (Vertical Total = 1125 / Display = 1080 / Blank = 45)

in FHD 120Hz 3D mode 、 (Vertical Total = 2250 / Display = 2160 / Blank = 90) in QFHD 30Hz/60Hz 3D mode.

Note (6) In 3D mode, the set up Fr in Typ. . In order to ensure that the electric function performance to avoid no display symptom.(Except picture quality symptom.)

Note (7) In 3D mode, the set up Tv and Tvb in Typ. . In order to ensure that the electric function performance to avoid no display symptom.(Except picture quality symptom.)

Note (8) The frame-to-frame jitter of the input frame rate is defined as the above figures. $FR_n = FR_{n-1} \pm 1.8\%$.

Note (9) The setup of the frame rate jitter > 1.8% may result in the cosmetic LED backlight symptom but the electric function is not affected.

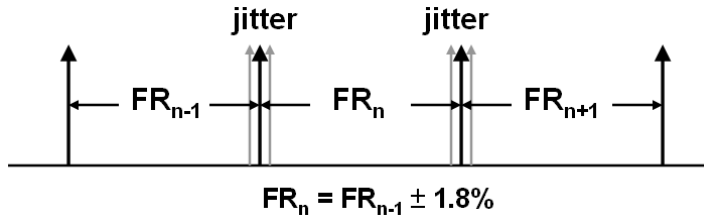

CONFIDENTIAL

6.2 V by One Input Signal Timing Diagram

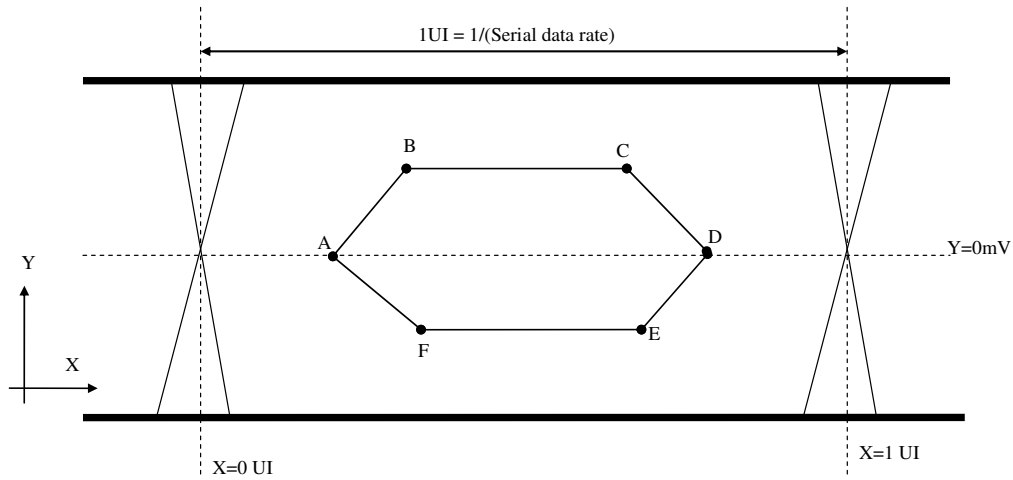

Table 1 Eye Mask Specification

	X [UI]	Y [mV]	Note
A	0.25	0	(1)
B	0.3	50	(1)
C	0.7	50	(1)
D	0.75	0	(1)
E	0.7	-50	(1)
F	0.3	-50	(1)

Note (1) Input levels of V-by-One HS signals are comes from “V-by-One HS Stander Ver.1.4”

6.3 Byte Length and Color mapping of V-by-One HS

Packer input & Unpacker output		30bpp RGB (10bit)
	D[0]	R[2]
	D[1]	R[3]
	D[2]	R[4]
Byte 0	D[3]	R[5]
	D[4]	R[6]
	D[5]	R[7]
	D[6]	R[8]
	D[7]	R[9]
Byte 1	D[8]	G[2]

CONFIDENTIAL

PRODUCT SPECIFICATION

CONFIDENTIAL

	D[9]	G[3]
	D[10]	G[4]
	D[11]	G[5]
	D[12]	G[6]
	D[13]	G[7]
	D[14]	G[8]
	D[15]	G[9]
	D[16]	B[2]
	D[17]	B[3]
	D[18]	B[4]
Byte 2	D[19]	B[5]
	D[20]	B[6]
	D[21]	B[7]
	D[22]	B[8]
	D[23]	B[9]
	D[24]	X
	D[25]	X
	D[26]	B[0]
Byte 3	D[27]	B[1]
	D[28]	G[0]
	D[29]	G[1]
	D[30]	R[0]
	D[31]	R[1]

6.4 POWER ON/OFF SEQUENCE

(Ta = 25 ± 2 °C)

To prevent a latch-up or DC operation of LCD module, the power on/off sequence should be as the diagram below.

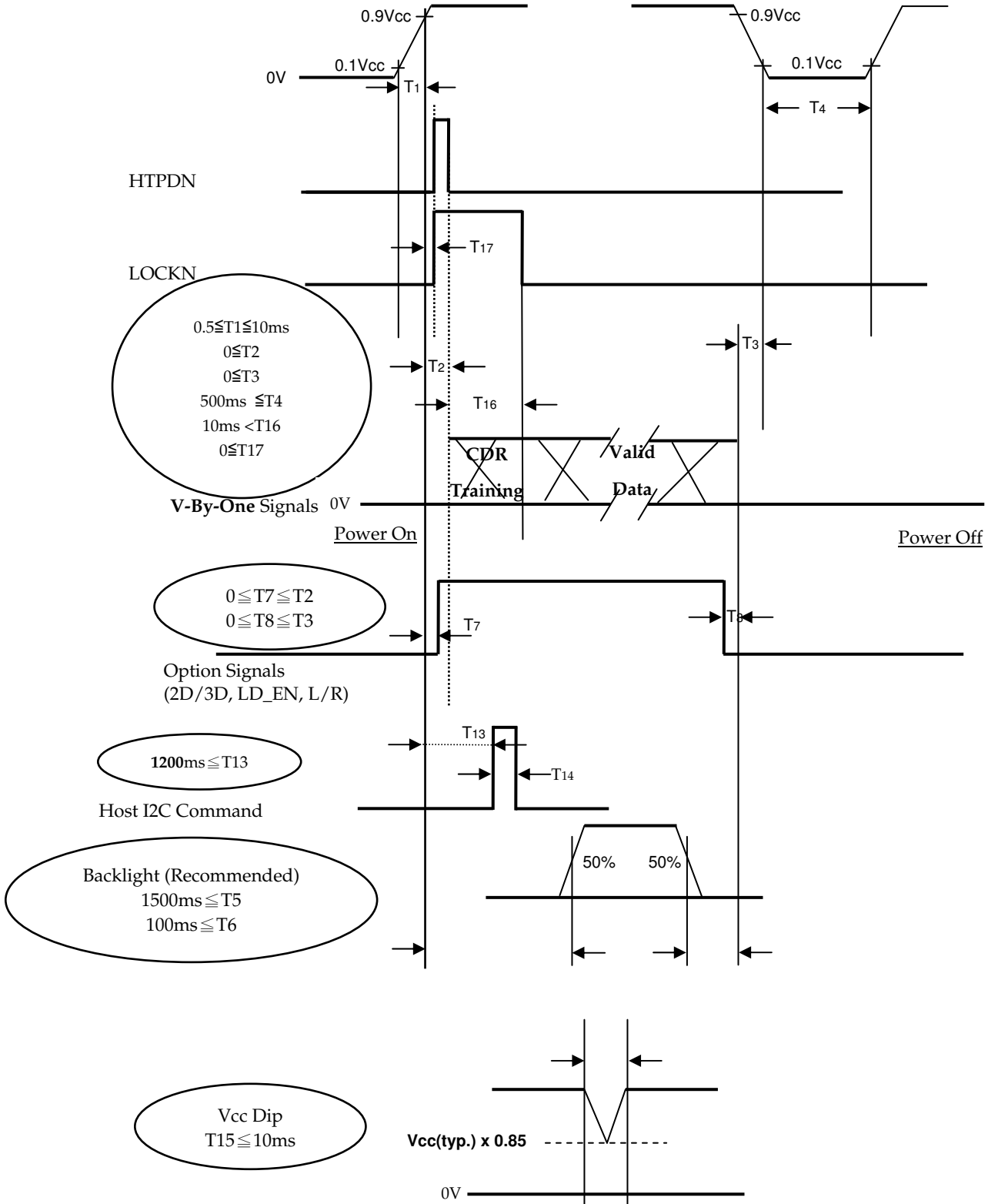

CONFIDENTIAL

6.5 2D/3D MODE CHANGE SIGNAL SEQUENCE WITHOUT VCC TURN OFF AND TURN ON

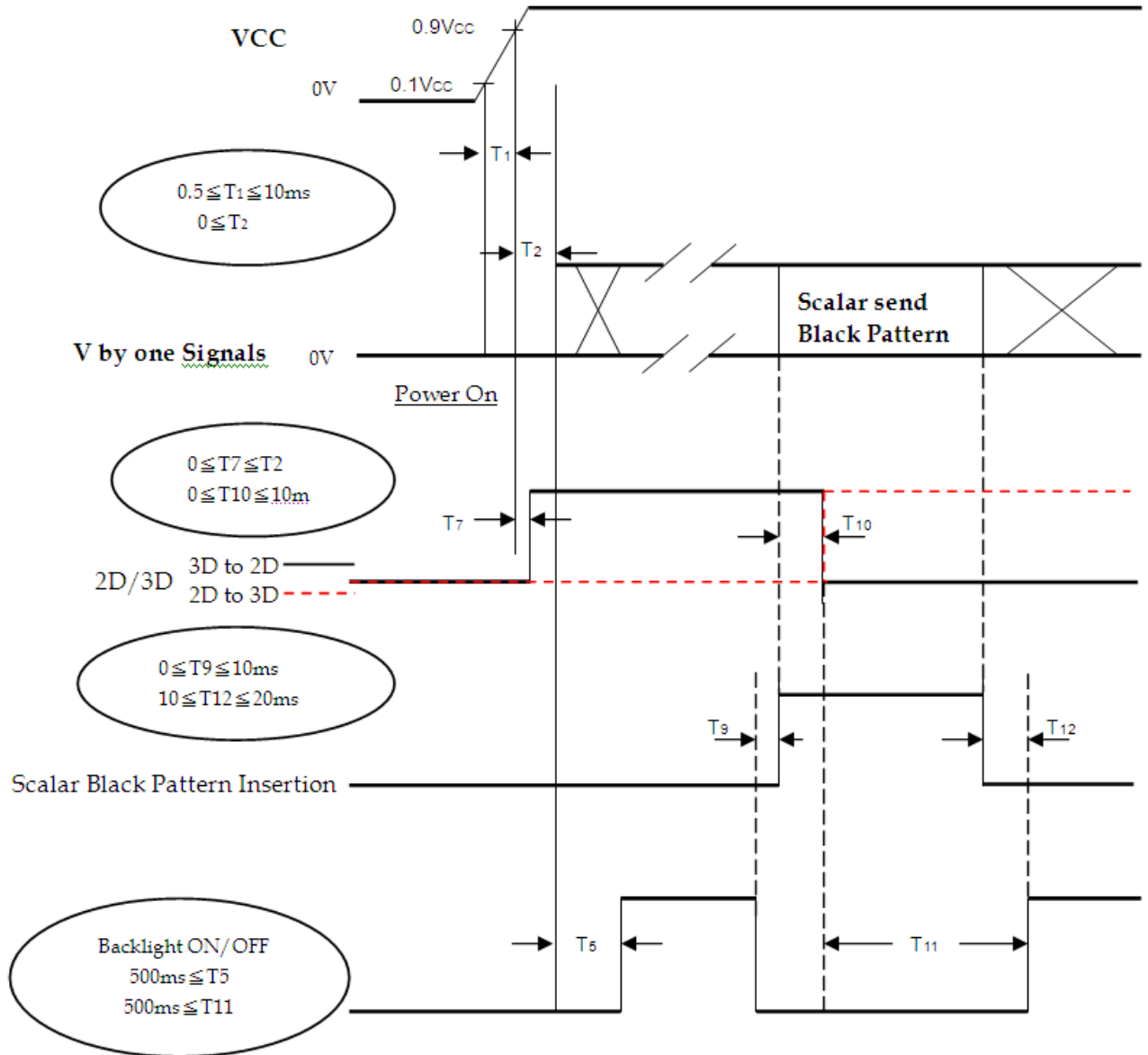

- Note (1) The supply voltage of the external system for the module input should follow the definition of Vcc.
- Note (2) Apply the LED voltage within the LCD operation range. When the backlight turns on before the LCD operation or the LCD turns off before the backlight turns off, the display may momentarily become abnormal screen.
- Note (3) In case of Vcc is in off level, please keep the level of input signals on the low or high impedance. If T₂<0, that maybe cause electrical overstress failure.
- Note (4) T₄ should be measured after the module has been fully discharged between power off and on period.
- Note (5) Interface signal shall not be kept at high impedance when the power is on.
- Note (6) When 2D/3D mode is changed, TCON will insert black pattern internally. During black insertion, TCON would load required optical table and TCON parameter setting. The black insertion time should be longer than 650ms because TCON must recognize 2D or 3D format and set the correct parameter.
- Note (7) Vcc must decay smoothly when power-off.
- Note (8) T₅ Backlight turn on time depend on T₁₄ command length+T₁₃

CONFIDENTIAL

7. OPTICAL CHARACTERISTICS

7.1 TEST CONDITIONS

Item	Symbol	Value	Unit
Ambient Temperature	Ta	25±2	°C
Ambient Humidity	Ha	50±10	%RH
Supply Voltage	V _{CC}	12±1.2	V
Input Signal	According to typical value in "3. ELECTRICAL CHARACTERISTICS"		
Vertical Frame Rate	Fr	60	Hz

The LCD module should be stabilized at given temperature for 1 hour to avoid abrupt temperature change during measuring in a windless room.

Local Dimming Function should be Disable before testing to get the steady optical characteristics (According to 5.1 CNF1 Connector Pin Assignment, Pin no. "42")

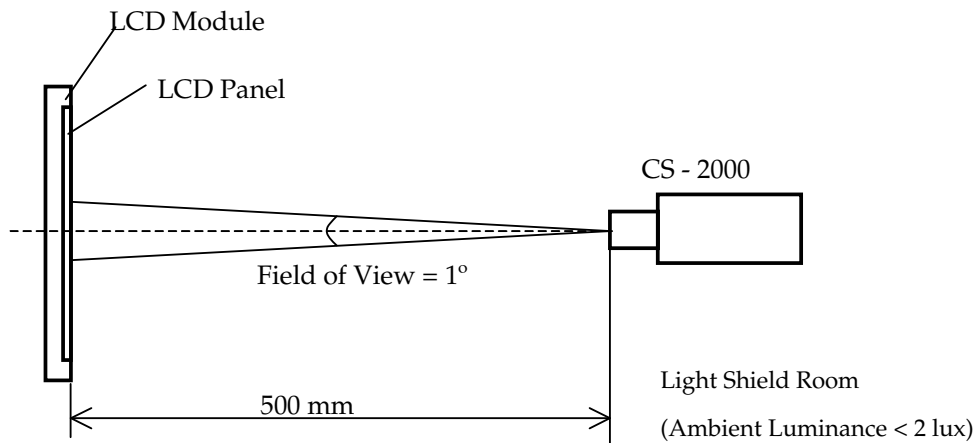

CONFIDENTIAL

7.2 OPTICAL SPECIFICATIONS

The relative measurement methods of optical characteristics are shown in 7.2. The following items should be measured under the test conditions described in 7.1 and stable environment shown in 7.1.

Item		Symbol	Condition	Min.	Typ.	Max.	Unit	Note		
Contrast Ratio		CR	$\theta_x=0^\circ, \theta_y=0^\circ$ Viewing angle at normal direction	2800	4000	-	-	Note (2)		
Response Time		Gray to gray			9.5	19	ms	Note (3)		
Center Luminance of White	L _C	2D		320	400	-	cd/m ²	Note (4)		
		3D			60	-	cd/m ²	Note (8)		
White Variation		δW				1.3	-	Note (6)		
Cross Talk	CT	2D		-		4	%	Note (5)		
		3D-W			4	-	%	Note (8)		
		3D-D			11	-	%	Note (8)		
Color Chromaticity	Red	R _x		$\theta_x=0^\circ, \theta_y=0^\circ$ Viewing angle at normal direction	Typ.- 0.03	Typ.+ 0.03		-		
		R _y						0.640		-
	Green	G _x	0.333					-		
		G _y	0.305					-		
	Blue	B _x	0.612					-		
		B _y	0.150					-		
	White	W _x	0.054					-		
		W _y	0.280					-		
	Correlated color temperature							9800		
Color Gamut		C.G.	-	72	-	%	NTSC			
Viewing Angle	Horizontal	θ_{x+}	CR≥20				-	Deg.		
		θ_{x-}					80		88	-
	Vertical	θ_{y+}					80		88	-
		θ_{y-}					80		88	-
Transmission direction of the up polarizer		Φ_{up}	-	-	90	-	Deg.	(7)		

CONFIDENTIAL

Note (1) Definition of Viewing Angle (θ_x, θ_y) :

Viewing angles are measured by Autronic Conoscope Cono-80 (or Eldim EZ-Contrast 160R).

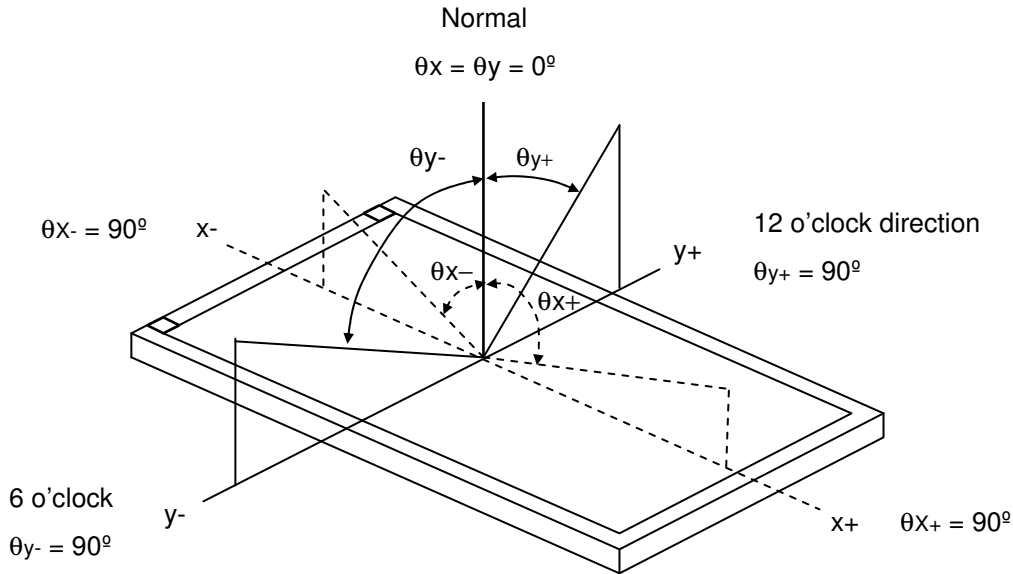

Note (2) Definition of Contrast Ratio (CR) :

The contrast ratio can be calculated by the following expression.

$$\text{Contrast Ratio (CR)} = \frac{\text{Surface Luminance of L1023}}{\text{Surface Luminance of L0}}$$

L1023: Luminance of gray level 1023

L 0: Luminance of gray level 0

CR = CR (X), where CR (X) is corresponding to the Contrast Ratio of the point X at the figure in Note (6).

Note (3) Definition of Gray-to-Gray Switching Time :

Optical Response

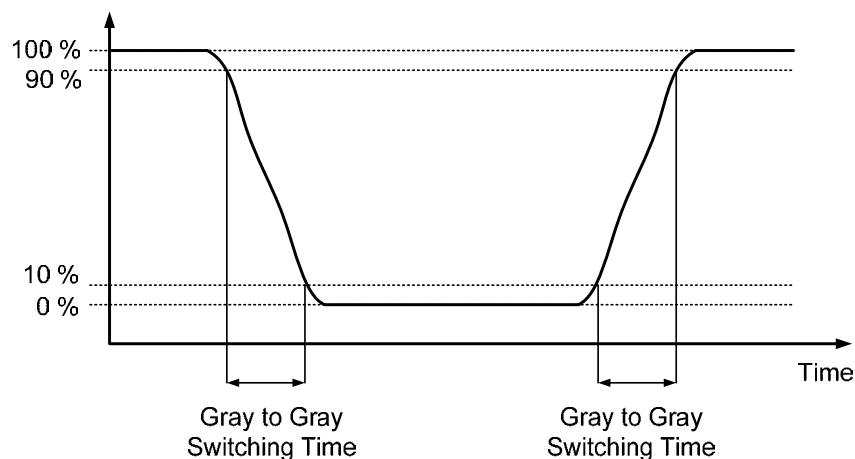

The driving signal means the signal of gray level 0, 124, 252, 380, 508, 636, 764, 892 and 1023.

Gray to gray average time means the average switching time of gray level 0, 124, 252, 380, 508, 636, 764, 892 and 1023 to each other.

Note (4) Definition of Luminance of White (L_c) :

CONFIDENTIAL

Measure the luminance of gray level 1023 at center point.

$L_C = L(5)$, where $L(x)$ is corresponding to the luminance of the point X at the figure in Note (6).

Note (5) Definition of Cross Talk (CT) :

$$CT = |Y_B - Y_A| / Y_A \times 100 (\%)$$

Where :

Y_A = Luminance of measured location without gray level 1023 pattern (cd/m²)

Y_B = Luminance of measured location with gray level 1023 pattern (cd/m²)

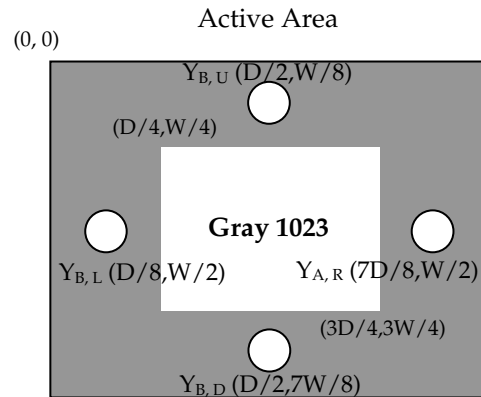
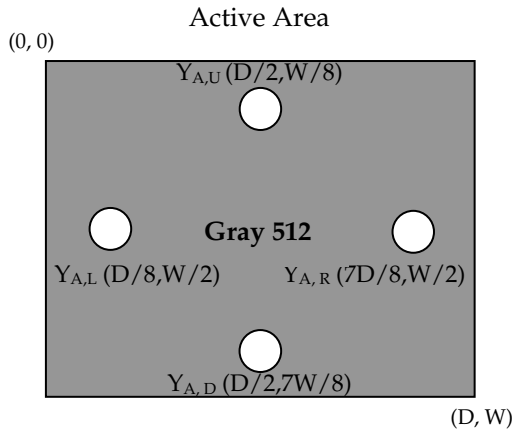

Note (6) Definition of White Variation (δW):

Measure the luminance of gray level 1023 at 5 points

$$\delta W = \frac{\text{Maximum } [L(1), L(2), L(3), L(4), L(5)]}{\text{Minimum } [L(1), L(2), L(3), L(4), L(5)]}$$

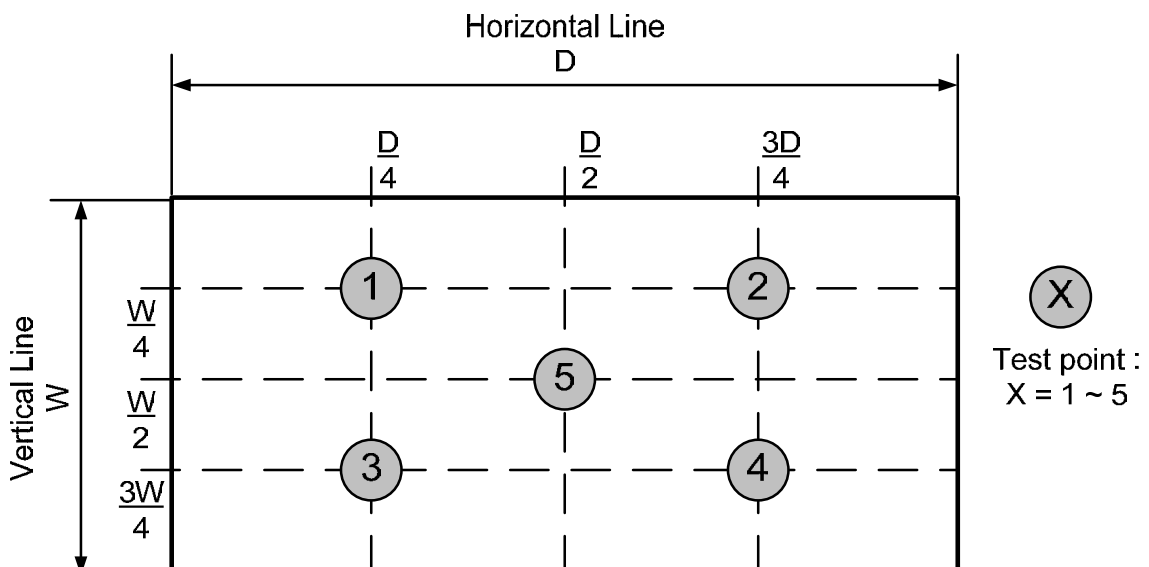

CONFIDENTIAL

Note (7) This is a reference for designing the shutter glasses of 3D application. Definition of the transmission direction of the up polarizer (Φ_{up-P}) on LCD Module :

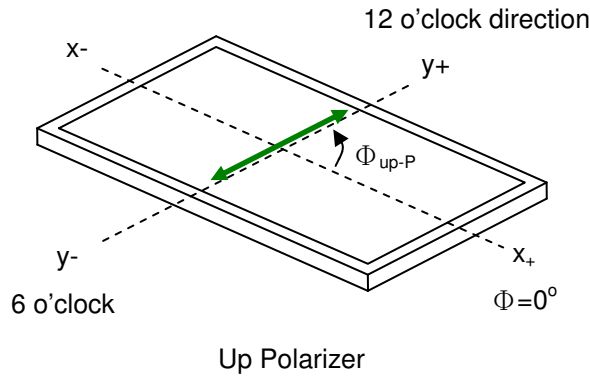

The transmission axis of the front polarizer of the shutter glasses should be parallel to this panel transmission direction to get a maximum 3D mode luminance.

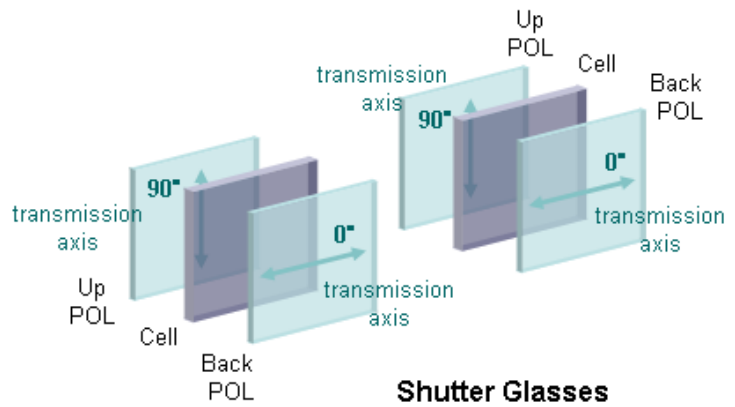
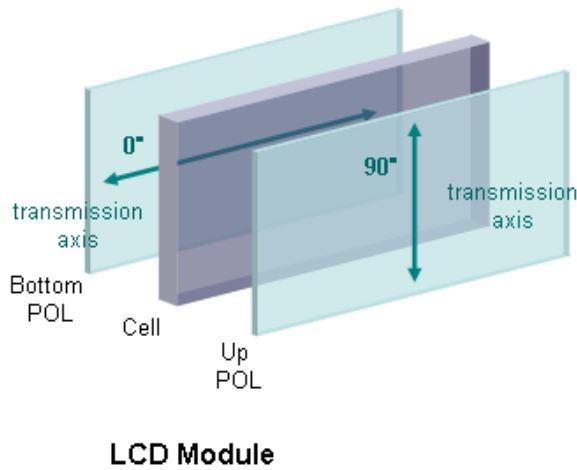

CONFIDENTIAL

Note (8) Definition of the 3D mode performance (measured under 3D mode, use INX's shutter glass) :

a. Test pattern

Left eye image and right eye image are displayed alternated

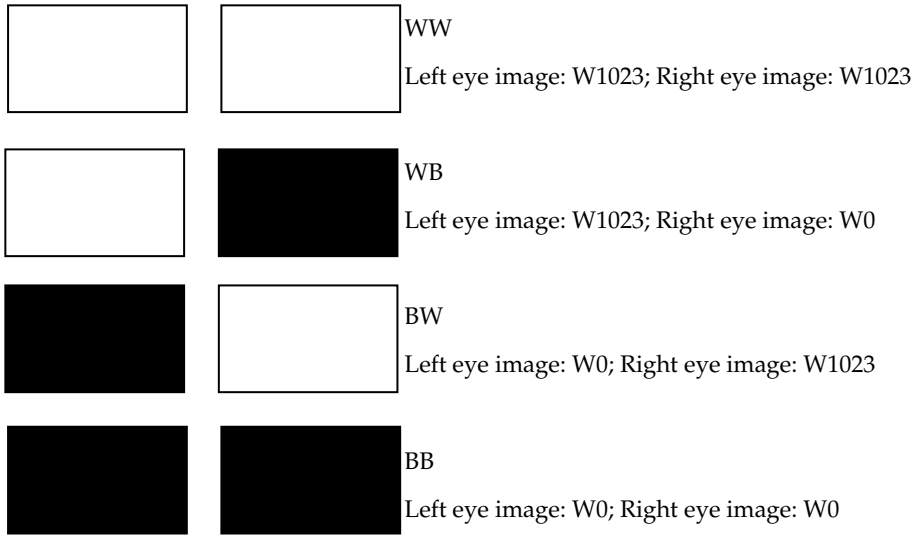

b. Measurement setup

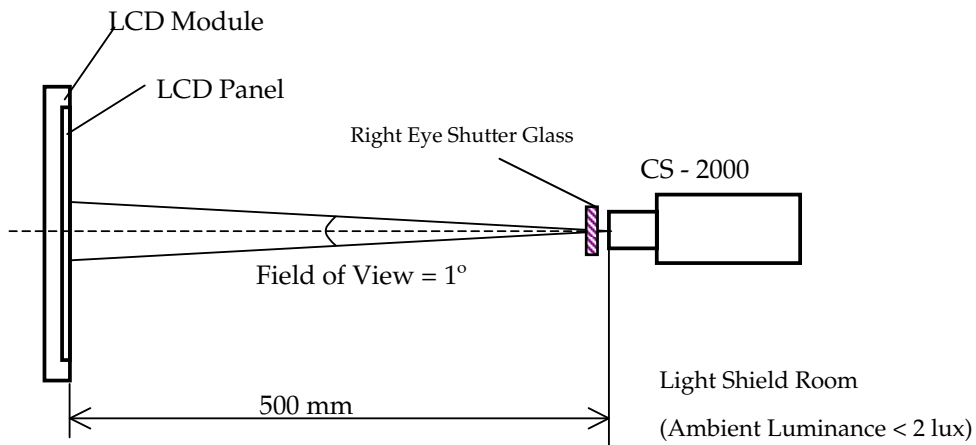

Shutter glasses are well controlled under suitable timing, and measure the luminance of the center point of the panel through the right eye glass. The transmittance of the glass should be larger than 40.0% under 3D mode operation. The luminance of the test pattern "WW", denoted $L(WW)$; the luminance of the test pattern "WB", denoted $L(WB)$; the luminance of the test pattern "BW", denoted $L(BW)$; the luminance of the test pattern "BB", denoted $L(BB)$

c. Definition of the Center Luminance of White, $L_c(3D)$: $L(WW)$

d. Definition of the 3D mode white crosstalk, $CT(3D-W)$: $CT(3D-W) \equiv \frac{L(WB) - L(BB)}{L(WW) - L(BB)}$

e. Definition of the 3D mode dark crosstalk, $CT(3D-D)$: $CT(3D-D) \equiv \frac{L(WW) - L(BW)}{L(WW) - L(BB)}$

8. PRECAUTIONS
8.1 ASSEMBLY AND HANDLING PRECAUTIONS

- (1) Do not apply rough force such as bending or twisting to the module during assembly.
- (2) It is recommended to assemble or to install a module into the user's system in clean working areas. The dust and oil may cause electrical short or worsen the polarizer.
- (3) Do not apply pressure to the module (including Active Area) to prevent the damage of LCD panel and backlight.
- (4) Always follow the correct power-on sequence when the LCD module is turned on. This can prevent the damage and latch-up of the CMOS LSI chips.
- (5) Do not plug in or pull out the I/F connector while the module is in operation.
- (6) Do not disassemble the module.
- (7) Use a soft dry cloth without chemicals for cleaning, because the surface of polarizer is very soft and easily scratched.
- (8) Moisture can easily penetrate into LCD module and may cause the damage during operation.
- (9) High temperature or humidity may deteriorate the performance of LCD module. Please store LCD modules in the specified storage conditions.
- (10) When ambient temperature is lower than 10°C, the display quality might be reduced. For example, the response time will become slow, and the starting voltage of LED will be higher than that of room temperature.

8.2 SAFETY PRECAUTIONS

- (1) The startup voltage of a backlight is over 1000 Volts. It may cause an electrical shock while assembling with the inverter. Do not disassemble the module or insert anything into the backlight unit.
- (2) If the liquid crystal material leaks from the panel, it should be kept away from the eyes or mouth. In case of contact with hands, skin or clothes, it has to be washed away thoroughly with soap.
- (3) After the module's end of life, it is not harmful in case of normal operation and storage.

8.3 SAFETY STANDARDS

The LCD module should be certified with safety regulations as follows:

Regulatory	Item	Standard
Information Technology equipment	UL	UL60950-1:2006 or Ed.2:2007
	cUL	CAN/CSA C22.2 No.60950-1-03 or 60950-1-07
	CB	IEC60950-1:2005 / EN60950-1:2006+ A11:2009
Audio/Video Apparatus	UL	UL60065 Ed.7:2007
	cUL	CAN/CSA C22.2 No.60065-03:2006 + A1:2006
	CB	IEC60065:2001+ A1:2005 / EN60065:2002 + A1:2006+ A11:2008

If the module displays the same pattern for a long period of time, the phenomenon of image sticking may be occurred.

9. DEFINITION OF LABELS

9.1 MODULE LABEL

The barcode nameplate is pasted on each module as illustration, and its definitions are as following explanation.



Model Name : V500DK2-KS1

Revision : Rev. XX, for example: A0, A1... B1, B2... or C1, C2...etc.

Serial ID : XXXXXXYYMDLNNNN

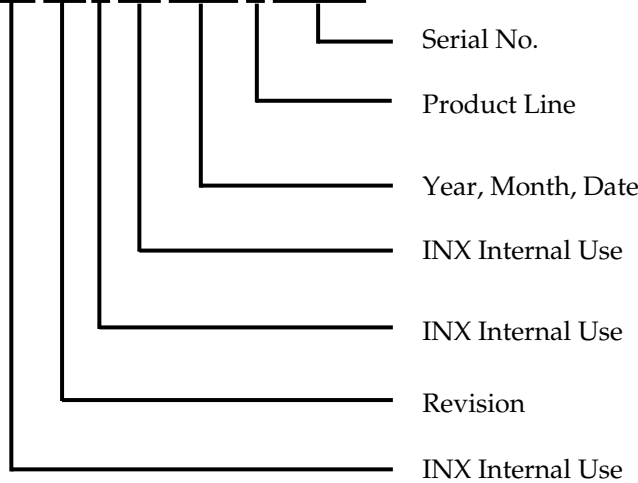

Serial ID includes the information as below :

Manufactured Date :

Year : 2001=1, 2002=2, 2003=3, 2004=4...2010=0, 2011=1, 2012=2...

Month: 1~9, A~C, for Jan. ~ Dec.

Day: 1~9, A~Y, for 1st to 31st, exclude I ,O, and U.

Revision Code : Cover all the change

Serial No. : Manufacturing sequence of product

Product Line : 1→Line1, 2→Line 2, ...etc.

CONFIDENTIAL

9.2 CARTON LABEL

The barcode nameplate is pasted on each box as illustration, and its definitions are as following explanation.

P.O. NO. _____

Parts ID. _____

Model Name V500DK2-KS1

Carton ID.  Quantities _____

XXXXXXXXXXXXXXXXXX

Made In Taiwan (Made In China)

Model Name: V500DK2- KS1

Carton ID: X X X X X X Y M D X X X X

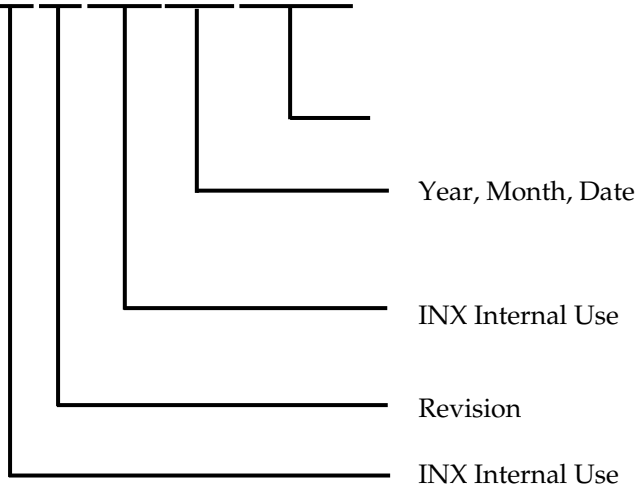

Serial ID includes the information as below :

Manufactured Date:

Year: 2010=0, 2011=1, 2012=2...etc.

Month: 1~9, A~C, for Jan. ~ Dec.

Day: 1~9, A~Y, for 1st to 31st, exclude I ,O, and U.

Revision Code: Cover all the change

CONFIDENTIAL

10. PACKAGING

10.1 PACKAGING SPECIFICATIONS

- (1) 22 LCD TV modules / 1 Box
- (2) Box dimensions : 1288(L) X 1138 (W) X 775 (H)
- (3) Weight: approximately 293 Kg

10.2 PACKAGING METHOD

Packaging method is shown in following figures.

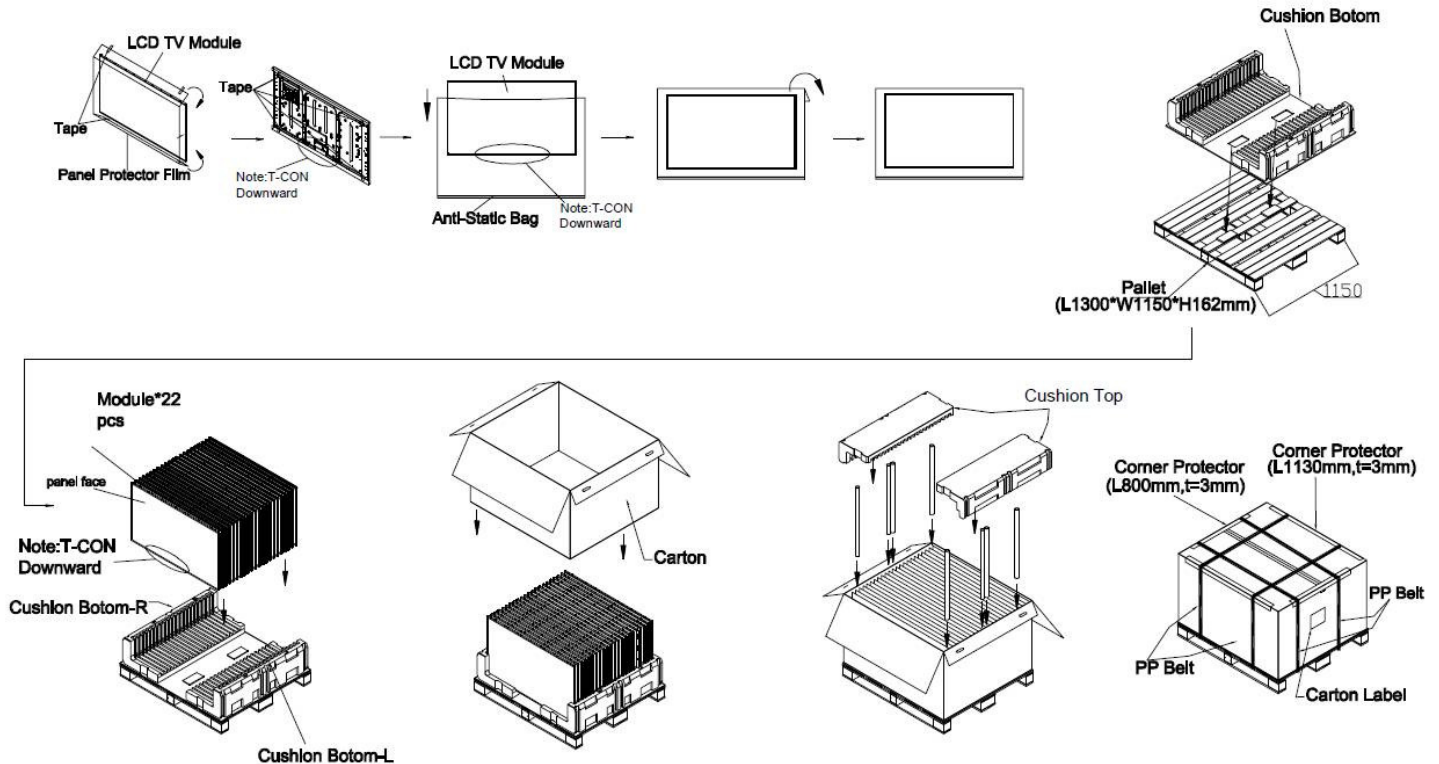

Figure 10-1 packing method

CONFIDENTIAL

**Sea / Land Transportation
(40ft HQ/40ft/20ft Container)**

Air Transportation

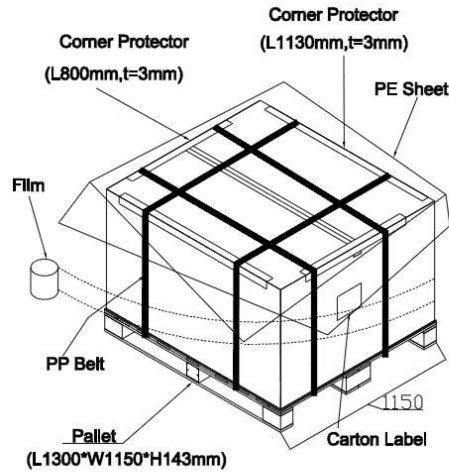
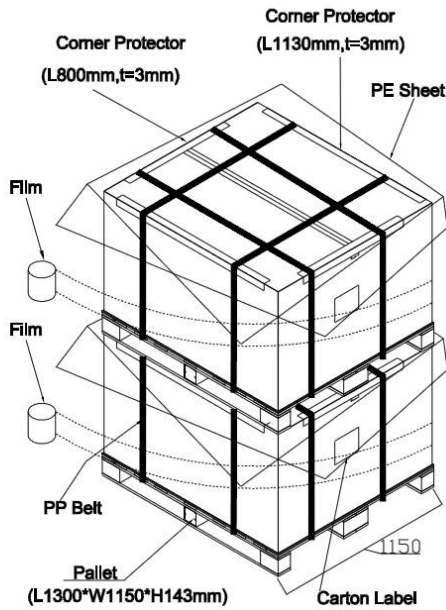

Figure 10-2 packing method

CONFIDENTIAL

10.3 UN-PACKAGING METHOD

Un-packaging method is shown in following figures.

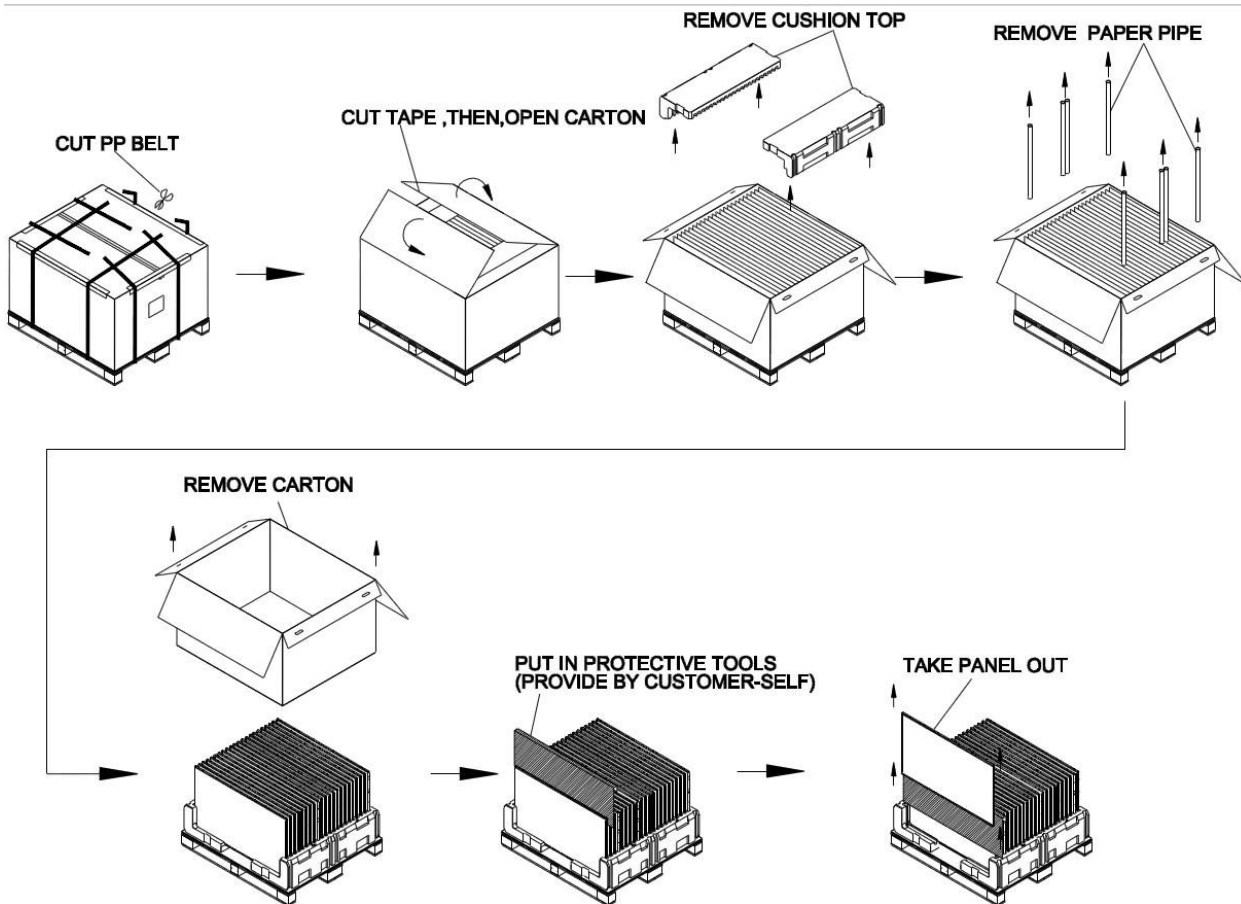
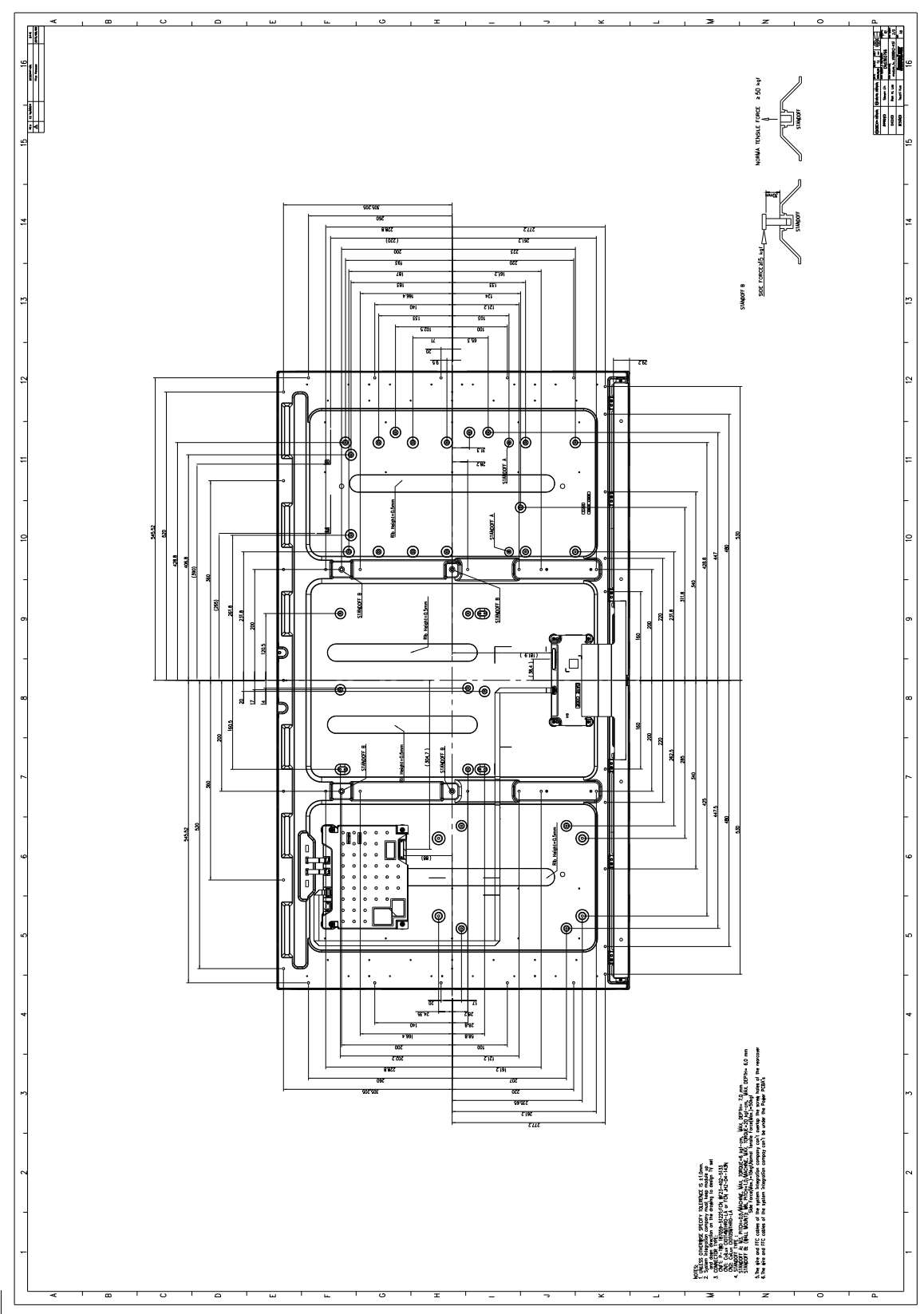

Figure 10-3 un-packaging method

CONFIDENTIAL



DISPLAYS

Engineered to fit your application, US Micro Products offers a wide range of standard and custom LCD solutions. We dedicate ourselves to providing the best in displays for the medical, industrial, gaming, automotive, aerospace, military and consumer markets.

OLEDs



TFTs



Open Frame Monitors



Passive LCDs



Multitouch



Touch Screen



As our customer, you receive expert knowledge, support and service. Our technical sales staff and experienced design engineers provide answers to your questions and engineered solutions to meet your displays needs.

PERIPHERAL DEVICES

Our full line of peripheral devices includes keyboards, trackballs, and printers. These rugged industrial products are designed to meet your demanding requirements and are available as both standard and custom solutions.

Keyboards



Trackballs



Aerospace Trackballs



Printers

