

# TFT SPECIFICATION

Part Number	USMP-T101-192120NDU-A0
Size	10.1"
Resolution	1920 x 1200
Brightness	800 cd/m <sup>2</sup>
Contrast	800:1
Viewing Angle	85/85/85/85
Operating Temp.	-30 ~ 80°C

FOR ADDITIONAL INFORMATION  
PLEASE CONTACT:  
[engineering@usmicroproducts.com](mailto:engineering@usmicroproducts.com)

Issue Date	Approved by (customer use)	Checked by	Prepared by

PROPRIETARY NOTE: THIS SPECIFICATION IS THE PROPERTY OF US MICRO PRODUCTS AND SHALL NOT BE REPRODUCED OR COPIED WITHOUT THE WRITTEN PERMISSION OF US MICRO PRODUCTS AND MUST BE RETURNED TO US MICRO PRODUCTS UPON ITS REQUEST.

**(800) 741-7755**  
[www.usmicroproducts.com](http://www.usmicroproducts.com)

## Contents

No.	ITEM	PAGE
1	COVER	1
2	RECORD OF REVISION	2
3	GENERAL DATA	4
4	ABSOLUTE MAXIMUM RATINGS	5
5	ELECTRICAL CHARACTERISTICS	6
6	OPTICAL CHARACTERISTICS	8
7	BLOCK DIAGRAM	10
8	RELIABILITY TESTS	11
9	LCD INTERFACE	12
10	OUTLINE DIMENSIONS	19
11	APPEARANCE STANDARD	21
12	PRECAUTIONS	23
13	DESIGNATION OF LOT MARK	25

## 2. RECORD OF REVISION

DATE	PAGE	SUMMARY																																							
Jun.30,'15	Page 4	3.1 DISPLAY FEATURES Revised : <table border="1" style="margin-left: 40px;"> <tr> <td>Power Consumption</td> <td>1.27W for LCD; 5.76W for Backlight</td> </tr> </table> <p style="text-align: center;">↓</p> <table border="1" style="margin-left: 40px;"> <tr> <td>Power Consumption</td> <td>2.21W for LCD; 5.76W for Backlight</td> </tr> </table>	Power Consumption	1.27W for LCD; 5.76W for Backlight	Power Consumption	2.21W for LCD; 5.76W for Backlight																																			
	Power Consumption	1.27W for LCD; 5.76W for Backlight																																							
	Power Consumption	2.21W for LCD; 5.76W for Backlight																																							
	Page 6	5.1 LCD CHARACTERISTICS Revised : <table border="1" style="margin-left: 40px;"> <thead> <tr> <th>Item</th> <th>Symbol</th> <th>Min.</th> <th>Typ.</th> <th>Max.</th> </tr> </thead> <tbody> <tr> <td>Power Supply Current</td> <td>I<sub>DD</sub></td> <td>-</td> <td>385</td> <td>800</td> </tr> </tbody> </table> <p style="text-align: center;">↓</p> <table border="1" style="margin-left: 40px;"> <thead> <tr> <th>Item</th> <th>Symbol</th> <th>Min.</th> <th>Typ.</th> <th>Max.</th> </tr> </thead> <tbody> <tr> <td>Power Supply Current</td> <td>I<sub>DD</sub></td> <td>-</td> <td>670</td> <td>800</td> </tr> </tbody> </table> Revised : Note 4	Item	Symbol	Min.	Typ.	Max.	Power Supply Current	I <sub>DD</sub>	-	385	800	Item	Symbol	Min.	Typ.	Max.	Power Supply Current	I <sub>DD</sub>	-	670	800																			
	Item	Symbol	Min.	Typ.	Max.																																				
Power Supply Current	I <sub>DD</sub>	-	385	800																																					
Item	Symbol	Min.	Typ.	Max.																																					
Power Supply Current	I <sub>DD</sub>	-	670	800																																					
Page 10	7. BLOCK DIAGRAM Added : Gamma Voltage Generator																																								
Page 12	9.1 INTERFACE PIN CONNECTIONS Revised : connector CN1 is 300E50-0010RA-G3 made by STARCONN <p style="text-align: center;">↓</p> connector CN1 is 51296-5094 made by MOLEX  Note 2: Normal brightness: 0% PWM duty <p style="text-align: center;">↓</p> Note 2: Normal brightness: 100% PWM duty																																								
Page 14	9.4 TIMING CHART Revised : Data bits [0:5] → [0:7]																																								
Oct.28,'15	Page 4	3.1 DISPLAY FEATURES Revised : <table border="1" style="margin-left: 40px;"> <tr> <td>Power Consumption</td> <td>2.21W for LCD; 5.76W for Backlight</td> </tr> </table> <p style="text-align: center;">↓</p> <table border="1" style="margin-left: 40px;"> <tr> <td>Power Consumption</td> <td>2.21W for LCD; 7.68W for Backlight</td> </tr> </table>	Power Consumption	2.21W for LCD; 5.76W for Backlight	Power Consumption	2.21W for LCD; 7.68W for Backlight																																			
	Power Consumption	2.21W for LCD; 5.76W for Backlight																																							
Power Consumption	2.21W for LCD; 7.68W for Backlight																																								
Page 6	5.1 LCD CHARACTERISTICS Revised : <table border="1" style="margin-left: 40px;"> <thead> <tr> <th>Item</th> <th>Condition</th> <th>Min.</th> <th>Typ.</th> <th>Max.</th> </tr> </thead> <tbody> <tr> <td>Input Voltage</td> <td>I<sub>LED</sub>= 480 mA</td> <td>11</td> <td>12</td> <td>13</td> </tr> <tr> <td>Input current</td> <td>100% duty</td> <td>-</td> <td>480</td> <td>-</td> </tr> <tr> <td>LED lifetime</td> <td>I<sub>LED</sub>= 480 mA</td> <td>-</td> <td>40K</td> <td>-</td> </tr> </tbody> </table> <p style="text-align: center;">↓</p> <table border="1" style="margin-left: 40px;"> <thead> <tr> <th>Item</th> <th>Condition</th> <th>Min.</th> <th>Typ.</th> <th>Max.</th> </tr> </thead> <tbody> <tr> <td>Input Voltage</td> <td>I<sub>LED</sub>= 640 mA</td> <td>11</td> <td>12</td> <td>13</td> </tr> <tr> <td>Input current</td> <td>100% duty</td> <td>-</td> <td>640</td> <td>760</td> </tr> <tr> <td>LED lifetime</td> <td>I<sub>LED</sub>= 640 mA</td> <td>-</td> <td>40K</td> <td>-</td> </tr> </tbody> </table> Note1、3 : 480mA → 640mA	Item	Condition	Min.	Typ.	Max.	Input Voltage	I <sub>LED</sub> = 480 mA	11	12	13	Input current	100% duty	-	480	-	LED lifetime	I <sub>LED</sub> = 480 mA	-	40K	-	Item	Condition	Min.	Typ.	Max.	Input Voltage	I <sub>LED</sub> = 640 mA	11	12	13	Input current	100% duty	-	640	760	LED lifetime	I <sub>LED</sub> = 640 mA	-	40K	-
Item	Condition	Min.	Typ.	Max.																																					
Input Voltage	I <sub>LED</sub> = 480 mA	11	12	13																																					
Input current	100% duty	-	480	-																																					
LED lifetime	I <sub>LED</sub> = 480 mA	-	40K	-																																					
Item	Condition	Min.	Typ.	Max.																																					
Input Voltage	I <sub>LED</sub> = 640 mA	11	12	13																																					
Input current	100% duty	-	640	760																																					
LED lifetime	I <sub>LED</sub> = 640 mA	-	40K	-																																					

## 2. RECORD OF REVISION

DATE	PAGE	SUMMARY												
Oct.28,'15	Page 8	6. OPTICAL CHARACTERISTICS Revised : <table border="1" style="margin-left: 40px;"> <thead> <tr> <th>Item</th> <th>Condition</th> </tr> </thead> <tbody> <tr> <td>Brightness of White</td> <td rowspan="3"><math>\phi = 0^\circ, \theta = 0^\circ,</math> <math>I_{LED} = 480 \text{ mA}</math></td> </tr> <tr> <td>Brightness Uniformity</td> </tr> <tr> <td>Contrast Ratio</td> </tr> </tbody> </table> <p style="text-align: center;">↓</p> <table border="1" style="margin-left: 40px;"> <thead> <tr> <th>Item</th> <th>Condition</th> </tr> </thead> <tbody> <tr> <td>Brightness of White</td> <td rowspan="3"><math>\phi = 0^\circ, \theta = 0^\circ,</math> <math>I_{LED} = 640 \text{ mA}</math></td> </tr> <tr> <td>Brightness Uniformity</td> </tr> <tr> <td>Contrast Ratio</td> </tr> </tbody> </table>	Item	Condition	Brightness of White	$\phi = 0^\circ, \theta = 0^\circ,$ $I_{LED} = 480 \text{ mA}$	Brightness Uniformity	Contrast Ratio	Item	Condition	Brightness of White	$\phi = 0^\circ, \theta = 0^\circ,$ $I_{LED} = 640 \text{ mA}$	Brightness Uniformity	Contrast Ratio
	Item	Condition												
	Brightness of White	$\phi = 0^\circ, \theta = 0^\circ,$ $I_{LED} = 480 \text{ mA}$												
Brightness Uniformity														
Contrast Ratio														
Item	Condition													
Brightness of White	$\phi = 0^\circ, \theta = 0^\circ,$ $I_{LED} = 640 \text{ mA}$													
Brightness Uniformity														
Contrast Ratio														
Page 17	9.7 POWER SEQUENCE Revised : Note3													
Page 22	11.2 LCD APPEARANCE SPECIFICATION Revised : <table border="1" style="margin-left: 40px;"> <thead> <tr> <th>Item</th> <th>Condition</th> </tr> </thead> <tbody> <tr> <td>1) Stains</td> <td rowspan="3"><math>0.2 \leq D \leq 0.6</math></td> </tr> <tr> <td>2) Foreign Materials</td> </tr> <tr> <td>3) Dark Spot</td> </tr> </tbody> </table> <p style="text-align: center;">↓</p> <table border="1" style="margin-left: 40px;"> <thead> <tr> <th>Item</th> <th>Condition</th> </tr> </thead> <tbody> <tr> <td>1) Stains</td> <td rowspan="3"><math>0.2 &lt; D \leq 0.6</math></td> </tr> <tr> <td>2) Foreign Materials</td> </tr> <tr> <td>3) Dark Spot</td> </tr> </tbody> </table>	Item	Condition	1) Stains	$0.2 \leq D \leq 0.6$	2) Foreign Materials	3) Dark Spot	Item	Condition	1) Stains	$0.2 < D \leq 0.6$	2) Foreign Materials	3) Dark Spot	
Item	Condition													
1) Stains	$0.2 \leq D \leq 0.6$													
2) Foreign Materials														
3) Dark Spot														
Item	Condition													
1) Stains	$0.2 < D \leq 0.6$													
2) Foreign Materials														
3) Dark Spot														

### 3. GENERAL DATA

#### 3.1 DISPLAY FEATURES

This module is a 10.1" WUXGA of 16:10 format amorphous silicon TFT. The pixel format is vertical stripe and sub pixels are arranged as R (red), G (green), B (blue) sequentially. This display is RoHS compliant, COG (chip on glass) technology and LED backlight are applied on this display.

Part Name	TBD
Module Dimensions	232.1(W) x 153.2(H) x 4.7(D) mm.(Expect PCB Area)
LCD Active Area	217.44(W) mm x 135.9(H) mm
Pixel Pitch	0.11325(W) mm x 0.11325 (H) mm
Resolution	1920 x 3(RGB)(W) x 1200(H) Dots
Color Pixel Arrangement	R, G, B Vertical Stripe
LCD Type	Transmissive Color TFT; Normally Black
Display Type	Active Matrix
Number of Colors	16.7M Colors (8-bit RGB)
Backlight	Light Emitting Diode (LED)
Weight	284 g
Interface	2ch-LVDS; 50 pins
Power Supply Voltage	3.3V for LCD; 12V for Backlight
Power Consumption	2.21W for LCD; 7.68W for Backlight
Viewing Direction	Super Wide Version (In-Plane Switching)

## 4. ABSOLUTE MAXIMUM RATINGS

Item	Symbol	Min.	Max.	Unit	Remarks
Supply Voltage	$V_{DD}$	-0.3	5	V	-
Input Voltage of Logic	$V_I$	-0.3	$V_{DD}+0.3$	V	Note 1
Operating Temperature	$T_{op}$	-30	80	°C	Note 2
Storage Temperature	$T_{st}$	-30	80	°C	Note 2
Backlight Input Voltage	$V_{LED}$	-	20	V	-

Note 1: The rating is defined for the signal voltages of the interface such as CLK and pixel data pairs.

Note 2: The maximum rating is defined as above based on the panel surface temperature, which might be different from ambient temperature after assembling the panel into the application. Moreover, some temperature-related phenomenon as below needed to be noticed:

- Background color, contrast and response time would be different in temperatures other than 25°C.
- Operating under high temperature will shorten LED lifetime.

## 5. ELECTRICAL CHARACTERISTICS

### 5.1 LCD CHARACTERISTICS

$T_a = 25\text{ }^\circ\text{C}$ ,  $V_{SS} = 0\text{V}$

Item	Symbol	Condition	Min.	Typ.	Max.	Unit	Remarks
Power Supply Voltage	$V_{DD}$	-	3.0	3.3	3.6	V	-
Differential Input Voltage for LVDS Receiver Threshold	$V_I$	"H" level	-	-	+100	mV	Note 1
		"L" level	-100	-	-		
Power Supply Current	$I_{DD}$	$V_{DD}=3.3\text{V}$	-	670	800	mA	Note 2
Frame Frequency	$f_{Frame}$	-	60			Hz	Note 3
CLK Frequency	$f_{CLK}$	-	75.91	78.36	79.89	MHz	

Note 1:  $V_{CM} 1.2\text{V}$  is common mode voltage of LVDS transmitter and receiver.

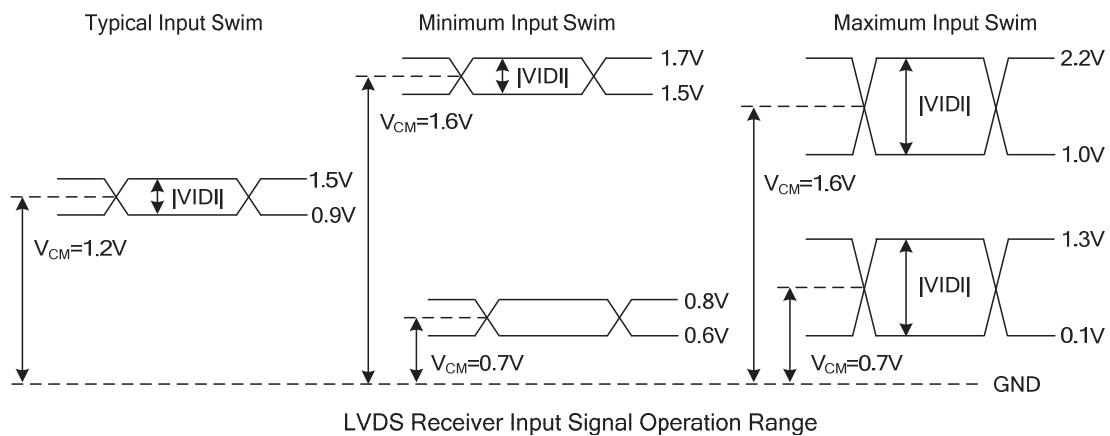

Note 2: An all white check pattern is used when measuring  $I_{DD}$ .  $f_{Frame}$  is set to 60 Hz.

Note 3: For LVDS transmitter input.

Note 4: 2A fuse is applied in the module for  $I_{DD}$ . For display activation and protection purpose, power supply is recommended larger than 5A to start the display and break fuse once any short circuit occurred.

## 5.2 BACKLIGHT CHARACTERISTICS

$T_a = 25\text{ }^\circ\text{C}$

Item	Symbol	Condition	Min.	Typ.	Max.	Unit	Remarks
Input Voltage	$V_{LED}$	$I_{LED} = 640\text{ mA}$	11	12	13	V	Note 1
Input current	$I_{LED}$	0% duty	-	10	-	mA	Note 2
		100% duty	-	640	760		
LED lifetime	-	$I_{LED} = 640\text{ mA}$	-	40K	-	hrs	Note 3

Note 1: As Fig. 5.1 shown, LED current is constant, 640 mA, controlled by the LED driver when applying 12V.

Note 2: Dimming function can be obtained by applying PWM signal from the display interface CN1. The recommended PWM signal is 1K ~ 10K Hz with 3.3V amplitude.

Note 3: The estimated lifetime is specified as the time to reduce 50% brightness by applying 640 mA at 25°C.

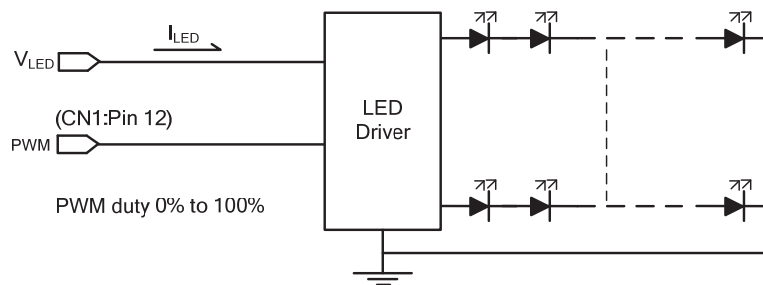

Fig 5.1



## 6. OPTICAL CHARACTERISTICS

The optical characteristics are measured based on the conditions as below:

- Supplying the signals and voltages defined in the section of electrical characteristics.
- The backlight unit needs to be turned on for 30 minutes.
- The ambient temperature is 25 °C .
- In the dark room less than 100 lx, the equipment has been set for the measurements as shown in Fig 6.1.

$T_a = 25\text{ }^\circ\text{C}$ ,  $f_{Frame} = 60\text{ Hz}$ ,  $V_{DD} = 3.3\text{V}$

Item	Symbol	Condition	Min.	Typ.	Max.	Unit	Remarks	
Brightness of White	-	$\phi = 0^\circ, \theta = 0^\circ$ , $I_{LED} = 640\text{ mA}$	640	800	-	$\text{cd/m}^2$	Note 1	
Brightness Uniformity	-		70	-	-	%	Note 2	
Contrast Ratio	CR		400	800	-	-	Note 3	
Response Time	$T_r + T_f$	$\phi = 0^\circ, \theta = 0^\circ$	-	25	-	ms	Note 4	
Viewing Angle	$\theta_x$	$\phi = 0^\circ, CR \geq 10$	-	85	-	Degree	Note 5	
	$\theta_{x'}$	$\phi = 180^\circ, CR \geq 10$	-	85	-			
	$\theta_y$	$\phi = 90^\circ, CR \geq 10$	-	85	-			
	$\theta_{y'}$	$\phi = 270^\circ, CR \geq 10$	-	85	-			
Color Chromaticity	Red	X	$\phi = 0^\circ, \theta = 0^\circ$	0.58	0.63	0.68	-	Note 6
		Y		0.27	0.32	0.37		
	Green	X		0.30	0.35	0.40		
		Y		0.52	0.57	0.62		
	Blue	X		0.10	0.15	0.20		
		Y		0.08	0.13	0.18		
	White	X		0.26	0.31	0.36		
		Y		0.30	0.35	0.40		

Note 1: The brightness is measured from the panel center point, P5 in Fig. 6.2, for the typical value.

Note 2: The brightness uniformity is calculated by the equation as below:

$$\text{Brightness uniformity} = \frac{\text{Min. Brightness}}{\text{Max. Brightness}} \times 100\%$$

which is based on the brightness values of the 9 points measured by BM-5 as shown in Fig. 6.2.

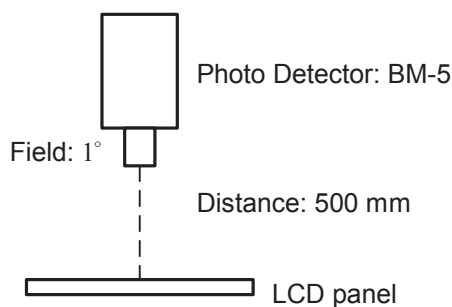

Fig. 6.1

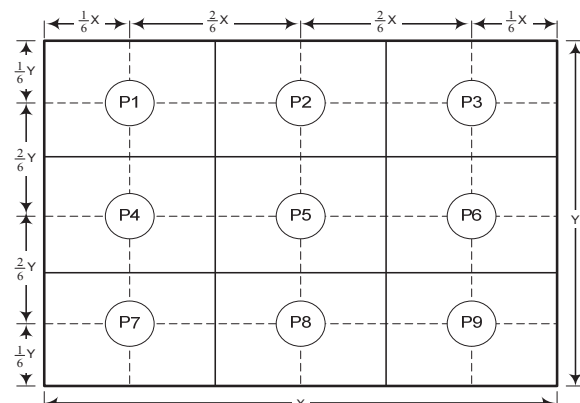

Fig. 6.2

Note 3: The Contrast Ratio is measured from the center point of the panel, P5, and defined as the following equation:

$$CR = \frac{\text{Brightness of White}}{\text{Brightness of Black}}$$

Note 4: The definition of response time is shown in Fig. 6.4. The rising time is the period from 10% brightness to 90% brightness when the data is from black to white. Oppositely, Falling time is the period from 90% brightness falling to 10% brightness.

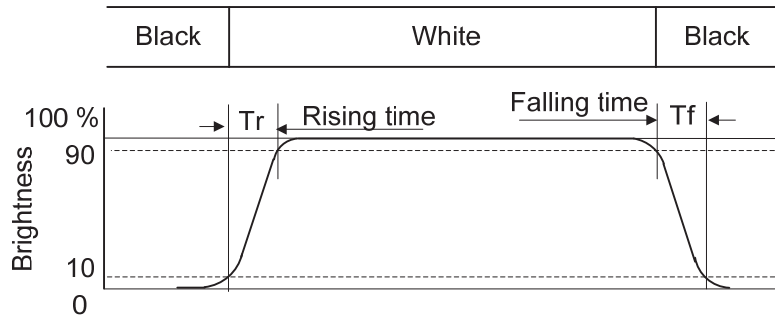

Fig.6.4

Note 5: The definition of viewing angle is shown in Fig. 6.5. Angle  $\phi$  is used to represent viewing directions, for instance,  $\phi = 270^\circ$  means 6 o'clock, and  $\phi = 0^\circ$  means 3 o'clock. Moreover, angle  $\theta$  is used to represent viewing angles from axis Z toward plane XY.

The display is super wide viewing angle version, so that the best optical performance can be obtained from every viewing direction.

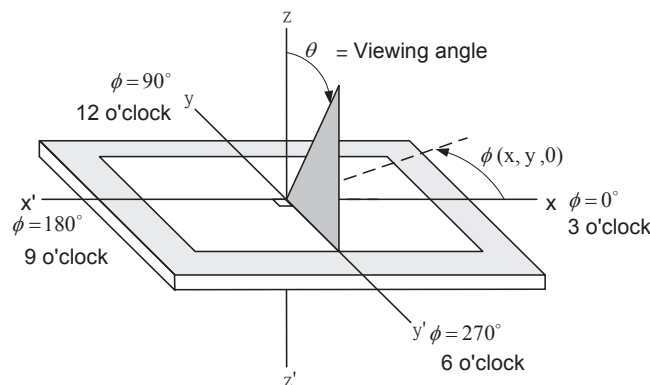
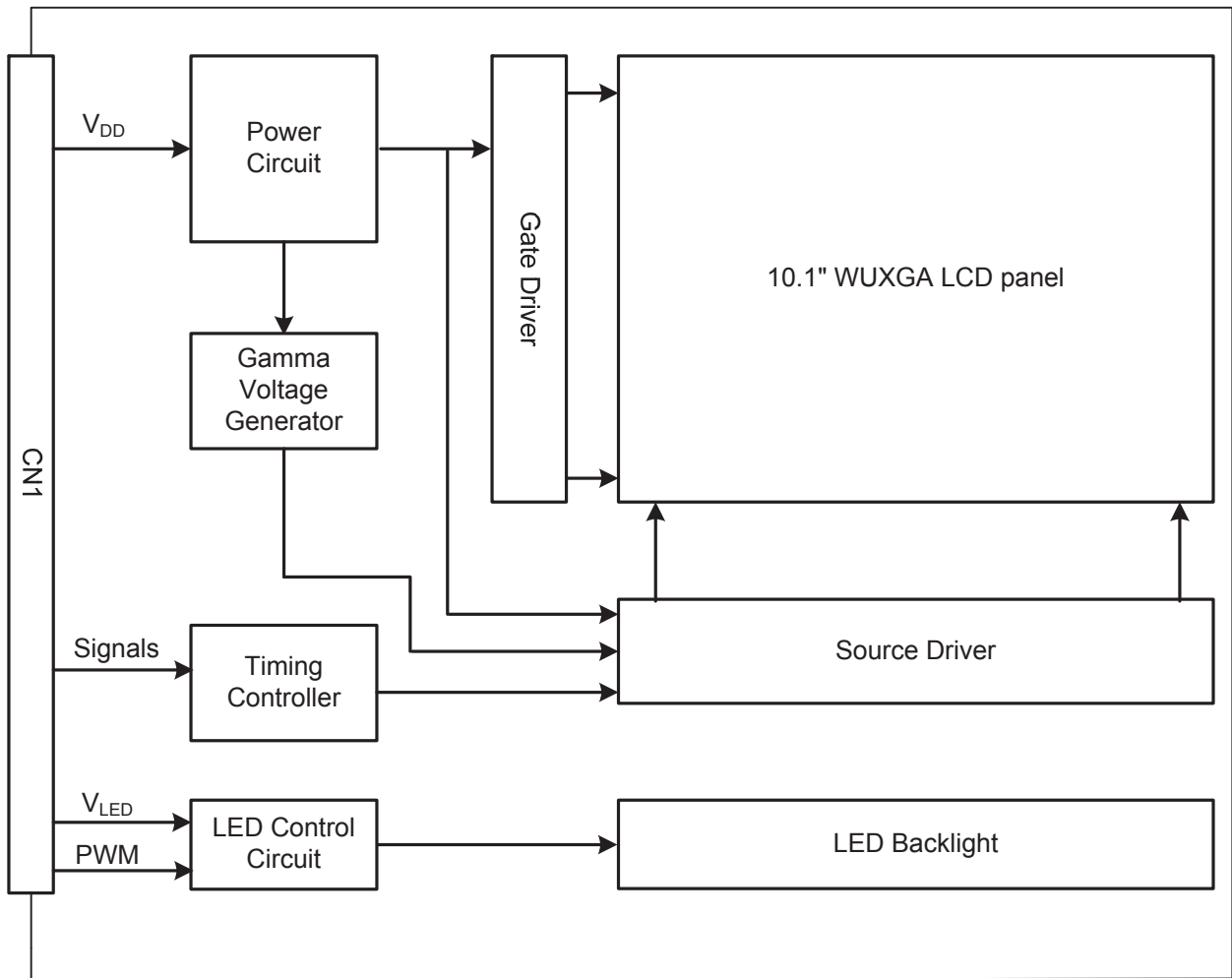

Fig 6.5

Note 6: The color chromaticity is measured from the center point of the panel, P5, as shown in Fig. 6.2.

## 7. BLOCK DIAGRAM



Note 1: Signals are CLK and pixel data pairs.

## 8. RELIABILITY TESTS

Test Item	Condition	
High Temperature	1) Operating 2) 80 °C	240 hrs
Low Temperature	1) Operating 2) -30 °C	240 hrs
High Temperature	1) Storage 2) 80 °C	240 hrs
Low Temperature	1) Storage 2) -30 °C	240 hrs
Heat Cycle	1) Operating 2) -20 °C ~70 °C 3) 3hrs~1hr~3hrs	240 hrs
Thermal Shock	1) Non-Operating 2) -35 °C ↔ 85 °C 3) 0.5 hr ↔ 0.5 hr	240 hrs
High Temperature & Humidity	1) Operating 2) 40 °C & 85%RH 3) Without condensation	240 hrs (Note 3)
Vibration	1) Non-Operating 2) 20~200 Hz 3) 2G 4) X, Y, and Z directions	1 hr for each direction
Mechanical Shock	1) Non-Operating 2) 10 ms 3) 50G 4) ±X, ±Y and ±Z directions	Once for each direction
ESD	1) Operating 2) Tip: 150 pF, 330 Ω 3) Air discharge for glass: ± 8KV 4) Contact discharge for metal frame: ± 8KV	1) Glass: 9 points 2) Metal frame: 8 points (Note 4)

Note 1: Display functionalities are inspected under the conditions defined in the specification after the reliability tests.

Note 2: The display is not guaranteed for use in corrosive gas environments.

Note 3: Under the condition of high temperature & humidity, if the temperature is higher than 40°C, the humidity needs to be reduced as Fig. 8.1 shown.

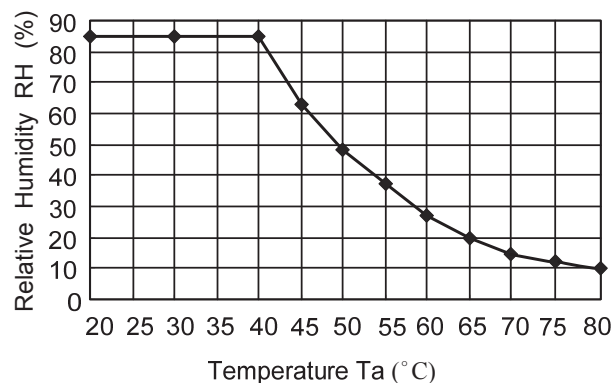

Fig. 8.1

Note 4: All pins of LCD interface (CN1) have been tested by ± 100V contact discharge of ESD under non-operating condition.

## 9. LCD INTERFACE

### 9.1 INTERFACE PIN CONNECTIONS

The display interface connector CN1 is 51296-5094 made by MOLEX and pin assignment is as below:

Pin No.	Symbol	Signal	Pin No.	Symbol	Signal
1	GND	Ground	26	OLV3N	Odd pixel LVDS data pair 3N
2	GND	Ground	27	OLV3P	Odd pixel LVDS data pair 3P
3	V <sub>DD</sub>	Power Supply 3.3V	28	GND	Ground
4	V <sub>DD</sub>	Power Supply 3.3V	29	ELV0N	Even pixel LVDS data pair 0N
5	V <sub>DD</sub>	Power Supply 3.3V	30	ELV0P	Even pixel LVDS data pair 0P
6	GND	Ground	31	GND	Ground
7	GND	Ground	32	ELV1N	Even pixel LVDS data pair 1N
8	NC	No Connection	33	ELV1P	Even pixel LVDS data pair 1P
9	NC	No Connection	34	GND	Ground
10	NC	No Connection	35	ELV2N	Even pixel LVDS data pair 2N
11	GND	Ground	36	ELV2P	Even pixel LVDS data pair 2P
12	PWM	BL Control Input	37	GND	Ground
13	GND	Ground	38	ELVCLKN	Even pixel LVDS clock pair N
14	OLV0N	Odd pixel LVDS data pair 0N	39	ELVCLKP	Even pixel LVDS clock pair P
15	OLV0P	Odd pixel LVDS data pair 0P	40	GND	Ground
16	GND	Ground	41	ELV3N	Even pixel LVDS data pair 3N
17	OLV1N	Odd pixel LVDS data pair 1N	42	ELV3P	Even pixel LVDS data pair 3P
18	OLV1P	Odd pixel LVDS data pair 1P	43	GND	Ground
19	GND	Ground	44	GND	Ground
20	OLV2N	Odd pixel LVDS data pair 2N	45	V <sub>LED</sub>	Power Supply for LED 12V
21	OLV2P	Odd pixel LVDS data pair 2P	46	V <sub>LED</sub>	Power Supply for LED 12V
22	GND	Ground	47	V <sub>LED</sub>	Power Supply for LED 12V
23	OLVCLKN	Odd pixel LVDS clock pair N	48	V <sub>LED</sub>	Power Supply for LED 12V
24	OLVCLKP	Odd pixel LVDS clock pair P	49	GND	Ground
25	GND	Ground	50	GND	Ground

Note 1: OVL<sub>n</sub>N/ELV<sub>n</sub>N and OVL<sub>n</sub>P/ELV<sub>n</sub>P (n=0, 1, 2, 3), OLVCLKN/ELVCLKN and OLVCLKP/ELVCLKP should be wired by twist-pairs or side-by-side FPC patterns, respectively.

Note 2: Normal brightness: 100% PWM duty; Brightness control: 0% to 100% PWM duty.

## 9.2 LVDS INTERFACE

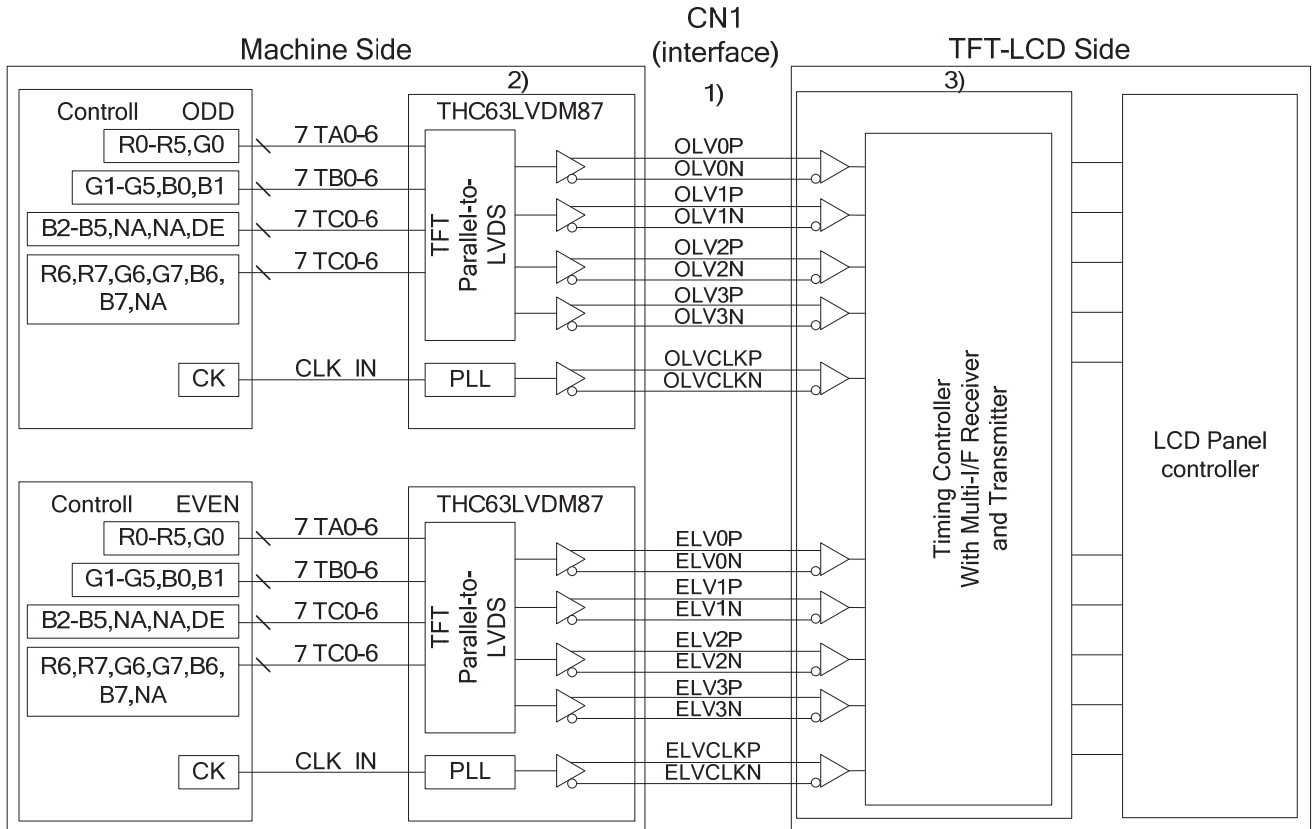

Note 1: LVDS cable impedance should be 100 ohms per signal line when each 2-lines (P, N) is used in differential mode.

Note 2: The recommended transmitter, TH63LVDM87, is made by Thine or equivalent, which is not contained in the module.

## 9.3 LVDS DATA FORMAT

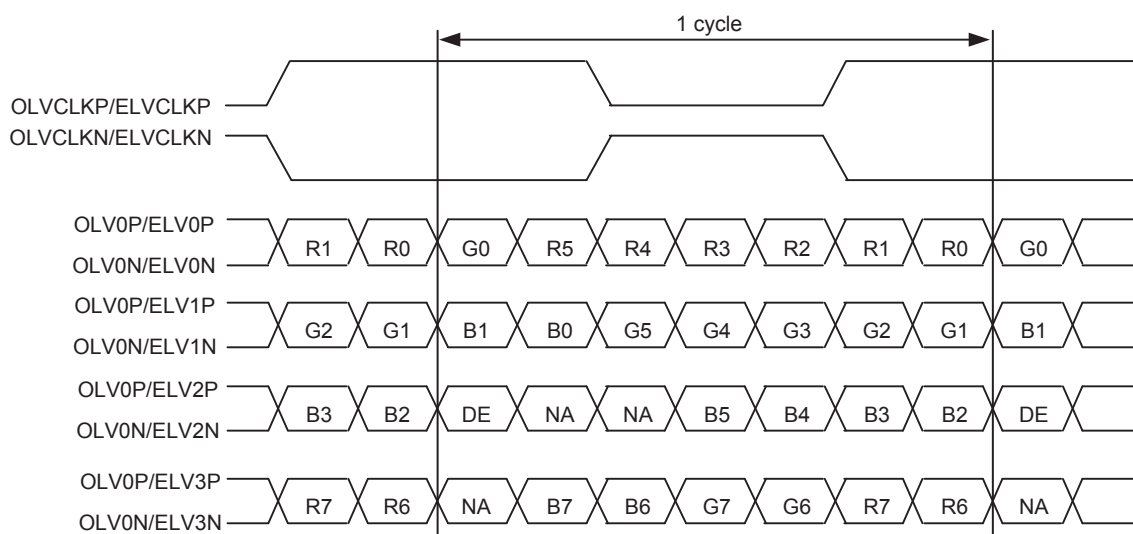

DE: Display Enable

NA: Not Available

### 9.4 TIMING CHART

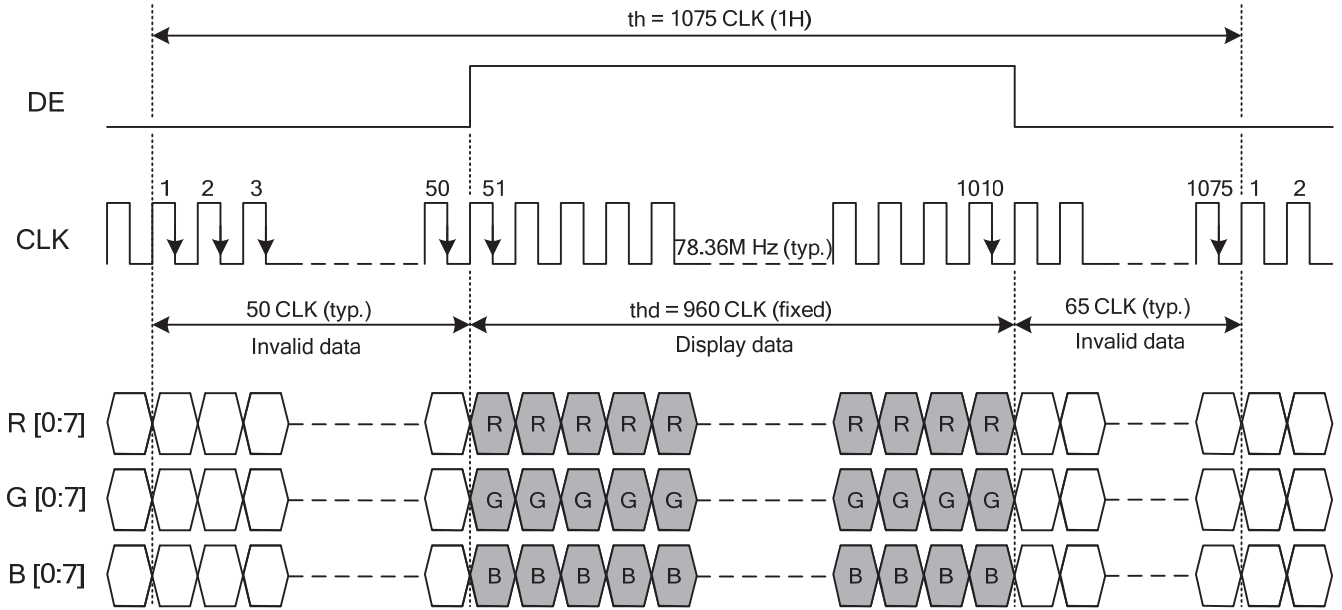

Fig. 9.1 Horizontal Timing

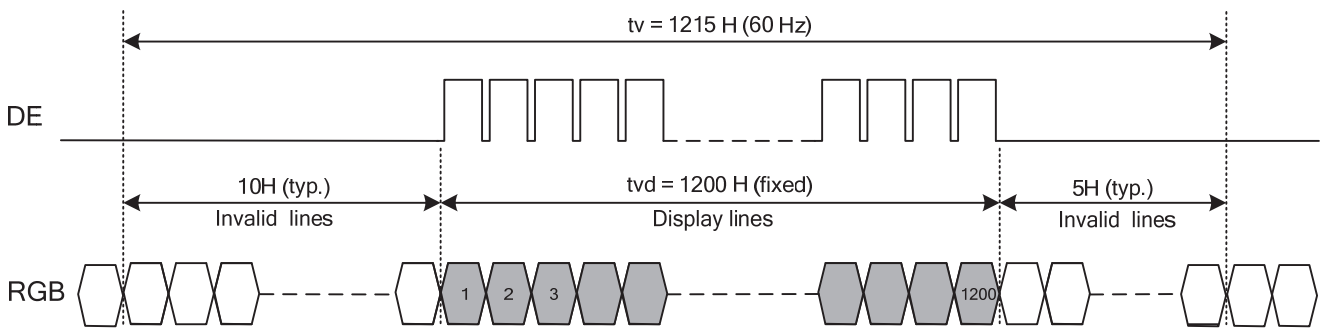

Fig. 9.2 Vertical Timing

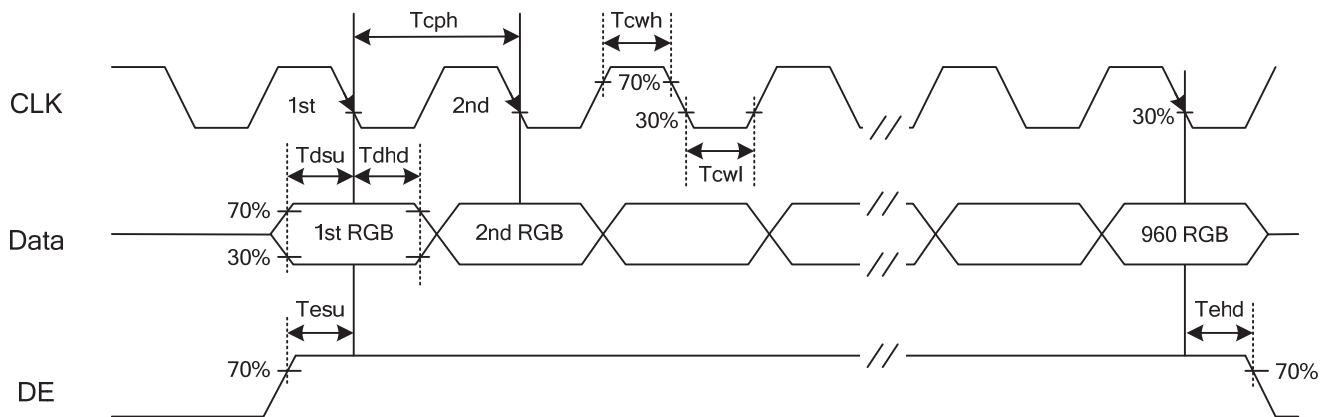

Fig. 9.3 Setup & Hold Time

## 9.5 TIMING TABLE

The column of timing sets including minimum, typical, and maximum as below are based on the best optical performance, frame frequency ( $f_{Frame}$ ) = 60Hz to define.

### A. DE MODE

Item		Symbol	Min.	Typ.	Max.	Unit
CLK Frequency		fclk	75.91	78.36	79.89	MHz
Horizontal	Display Data	thd	960			CLK
	Cycle Time	th	1050	1075	1087	
Vertical	Display Line	tvd	1200			H
	Cycle Time	tv	1210	1215	1225	

### B. CLOCK AND DATA INPUT TIMING

Item		Symbol	Min.	Typ.	Max.	Unit
CLK	Duty	Tcwh	47.5	50	52.5	%
	Cycle Time	Tcph	-	12.76	-	ns
Data	Setup Time	Tdsu	1	-	-	
	Hold Time	Tdhd	1	-	-	
DE	Setup Time	Tesu	1	-	-	
	Hold Time	Tehd	1	-	-	



### 9.6 LVDS RECEIVER TIMING

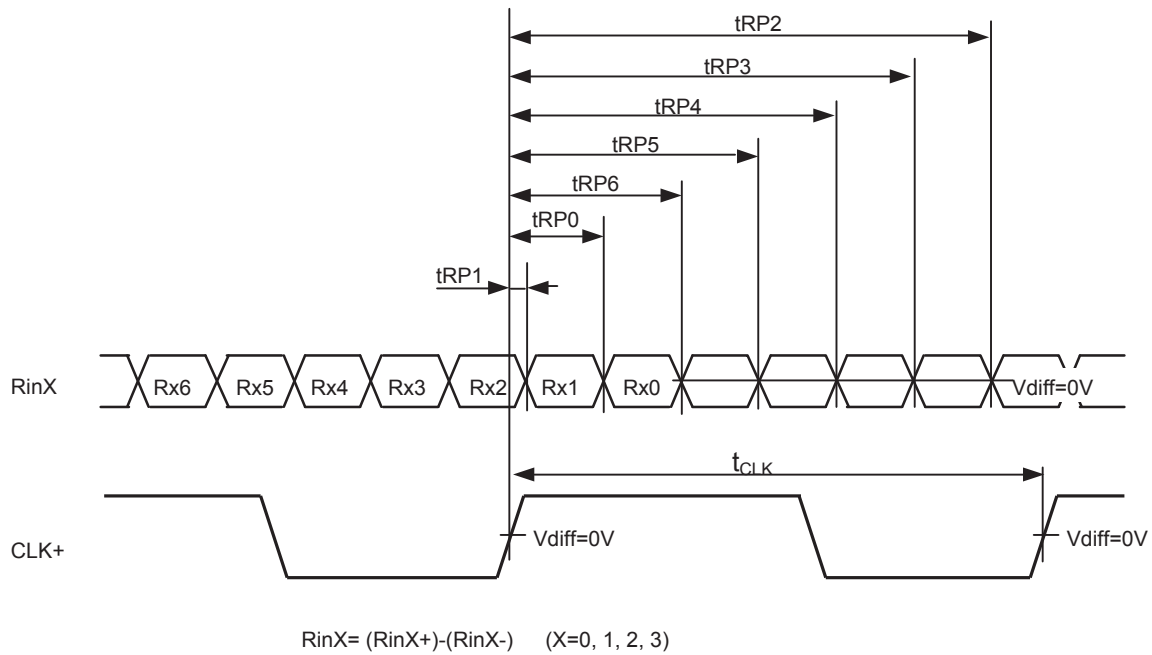

	Item	Symbol	Min.	Typ.	Max.	Unit
CLK	Cycle frequency	$1/t_{CLK}$	75.91	78.36	79.89	MHz
RinX (X=0,1,2,3)	0 data position	tRP0	$1/7 * t_{CLK} - 0.91$	$1/7 * t_{CLK}$	$1/7 * t_{CLK} + 0.91$	ns
	1st data position	tRP1	-0.91	0	+0.91	
	2nd data position	tRP2	$6/7 * t_{CLK} - 0.91$	$6/7 * t_{CLK}$	$6/7 * t_{CLK} + 0.91$	
	3rd data position	tRP3	$5/7 * t_{CLK} - 0.91$	$5/7 * t_{CLK}$	$5/7 * t_{CLK} + 0.91$	
	4th data position	tRP4	$4/7 * t_{CLK} - 0.91$	$4/7 * t_{CLK}$	$4/7 * t_{CLK} + 0.91$	
	5th data position	tRP5	$3/7 * t_{CLK} - 0.91$	$3/7 * t_{CLK}$	$3/7 * t_{CLK} + 0.91$	
	6th data position	tRP6	$2/7 * t_{CLK} - 0.91$	$2/7 * t_{CLK}$	$2/7 * t_{CLK} + 0.91$	

## 9.7 POWER SEQUENCE

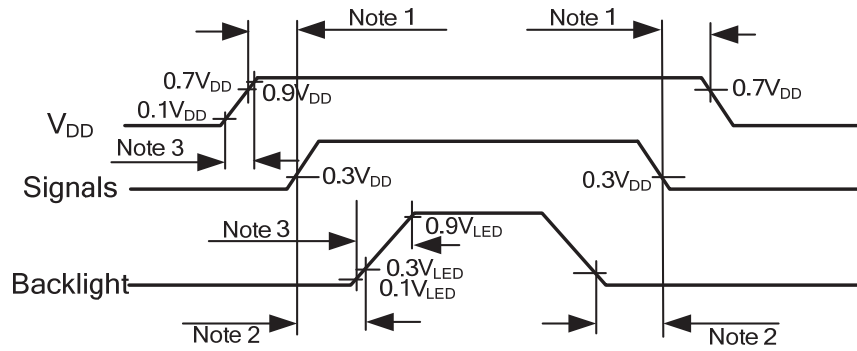

Note 1: In order to avoid any damages, V<sub>DD</sub> has to be applied before all other signals. The opposite is true for power off where V<sub>DD</sub> has to be remained on until all other signals have been switch off. The recommended time period is 1 second.

Note 2: In order to avoid showing uncompleted patterns in transient state. It is recommended that switching the backlight on is delayed for 1 second after the signals have been applied. The opposite is true for power off where the backlight has to be switched off 1 second before the signals are removed.

Note 3: In order to avoid high Inrush current, V<sub>DD</sub> & V<sub>LED</sub> rising time need to set at  
0.5ms < V<sub>DD</sub> & V<sub>LED</sub> < 10ms.

## 9.8 DATA INPUT for DISPLAY COLOR

Input color		Red Data								Green Data								Blue Data													
		R7	R6	R5	R4	R3	R2	R1	R0	G7	G6	G5	G4	G3	G2	G1	G0	B7	B6	B5	B4	B3	B2	B1	B0						
		MSB								LSB								MSB								LSB					
Basic Color	Black	0	0	0	0	0	0	0	0	0	0	0	0	0	0	0	0	0	0	0	0	0	0	0							
	Red(255)	1	1	1	1	1	1	1	1	0	0	0	0	0	0	0	0	0	0	0	0	0	0	0							
	Green(255)	0	0	0	0	0	0	0	0	1	1	1	1	1	1	1	1	0	0	0	0	0	0	0							
	Blue(255)	0	0	0	0	0	0	0	0	0	0	0	0	0	0	0	1	1	1	1	1	1	1	1							
	Cyan	0	0	0	0	0	0	0	0	1	1	1	1	1	1	1	1	1	1	1	1	1	1	1							
	Magenta	1	1	1	1	1	1	1	1	0	0	0	0	0	0	0	1	1	1	1	1	1	1	1							
	Yellow	1	1	1	1	1	1	1	1	1	1	1	1	1	1	1	0	0	0	0	0	0	0	0							
	White	1	1	1	1	1	1	1	1	1	1	1	1	1	1	1	1	1	1	1	1	1	1	1							
Red	Black	0	0	0	0	0	0	0	0	0	0	0	0	0	0	0	0	0	0	0	0	0	0								
	Red(1)	0	0	0	0	0	0	0	1	0	0	0	0	0	0	0	0	0	0	0	0	0	0								
	Red(2)	0	0	0	0	0	0	1	0	0	0	0	0	0	0	0	0	0	0	0	0	0	0								
	:	:	:	:	:	:	:	:	:	:	:	:	:	:	:	:	:	:	:	:	:	:	:	:							
	:	:	:	:	:	:	:	:	:	:	:	:	:	:	:	:	:	:	:	:	:	:	:	:							
	Red(253)	1	1	1	1	1	1	0	1	0	0	0	0	0	0	0	0	0	0	0	0	0	0	0							
	Red(254)	1	1	1	1	1	1	1	0	0	0	0	0	0	0	0	0	0	0	0	0	0	0	0							
Red(255)	1	1	1	1	1	1	1	1	0	0	0	0	0	0	0	0	0	0	0	0	0	0	0								
Green	Black	0	0	0	0	0	0	0	0	0	0	0	0	0	0	0	0	0	0	0	0	0	0								
	Green(1)	0	0	0	0	0	0	0	0	0	0	0	0	0	0	1	0	0	0	0	0	0	0								
	Green(2)	0	0	0	0	0	0	0	0	0	0	0	0	0	1	0	0	0	0	0	0	0	0								
	:	:	:	:	:	:	:	:	:	:	:	:	:	:	:	:	:	:	:	:	:	:	:	:							
	:	:	:	:	:	:	:	:	:	:	:	:	:	:	:	:	:	:	:	:	:	:	:	:							
	Green(253)	0	0	0	0	0	0	0	0	1	1	1	1	1	1	0	1	0	0	0	0	0	0	0							
	Green(254)	0	0	0	0	0	0	0	0	1	1	1	1	1	1	0	0	0	0	0	0	0	0	0							
Green(255)	0	0	0	0	0	0	0	0	1	1	1	1	1	1	1	0	0	0	0	0	0	0	0								
Blue	Black	0	0	0	0	0	0	0	0	0	0	0	0	0	0	0	0	0	0	0	0	0	0								
	Blue(1)	0	0	0	0	0	0	0	0	0	0	0	0	0	0	0	0	0	0	0	0	0	1								
	Blue(2)	0	0	0	0	0	0	0	0	0	0	0	0	0	0	0	0	0	0	0	0	0	1								
	:	:	:	:	:	:	:	:	:	:	:	:	:	:	:	:	:	:	:	:	:	:	:	:							
	:	:	:	:	:	:	:	:	:	:	:	:	:	:	:	:	:	:	:	:	:	:	:	:							
	Blue(253)	0	0	0	0	0	0	0	0	0	0	0	0	0	0	0	1	1	1	1	1	1	0	1							
	Blue(254)	0	0	0	0	0	0	0	0	0	0	0	0	0	0	0	1	1	1	1	1	1	1	0							
Blue(255)	0	0	0	0	0	0	0	0	0	0	0	0	0	0	0	1	1	1	1	1	1	1	1								

Note 1: Definition of gray scale : Color(n) Number in parenthesis indicates gray scale level. Larger number corresponds to brighter level.

Note 2: Data Signal : 1 : High, 0 : Low

**10. OUTLINE DIMENSIONS**  
10.1 FRONT VIEW

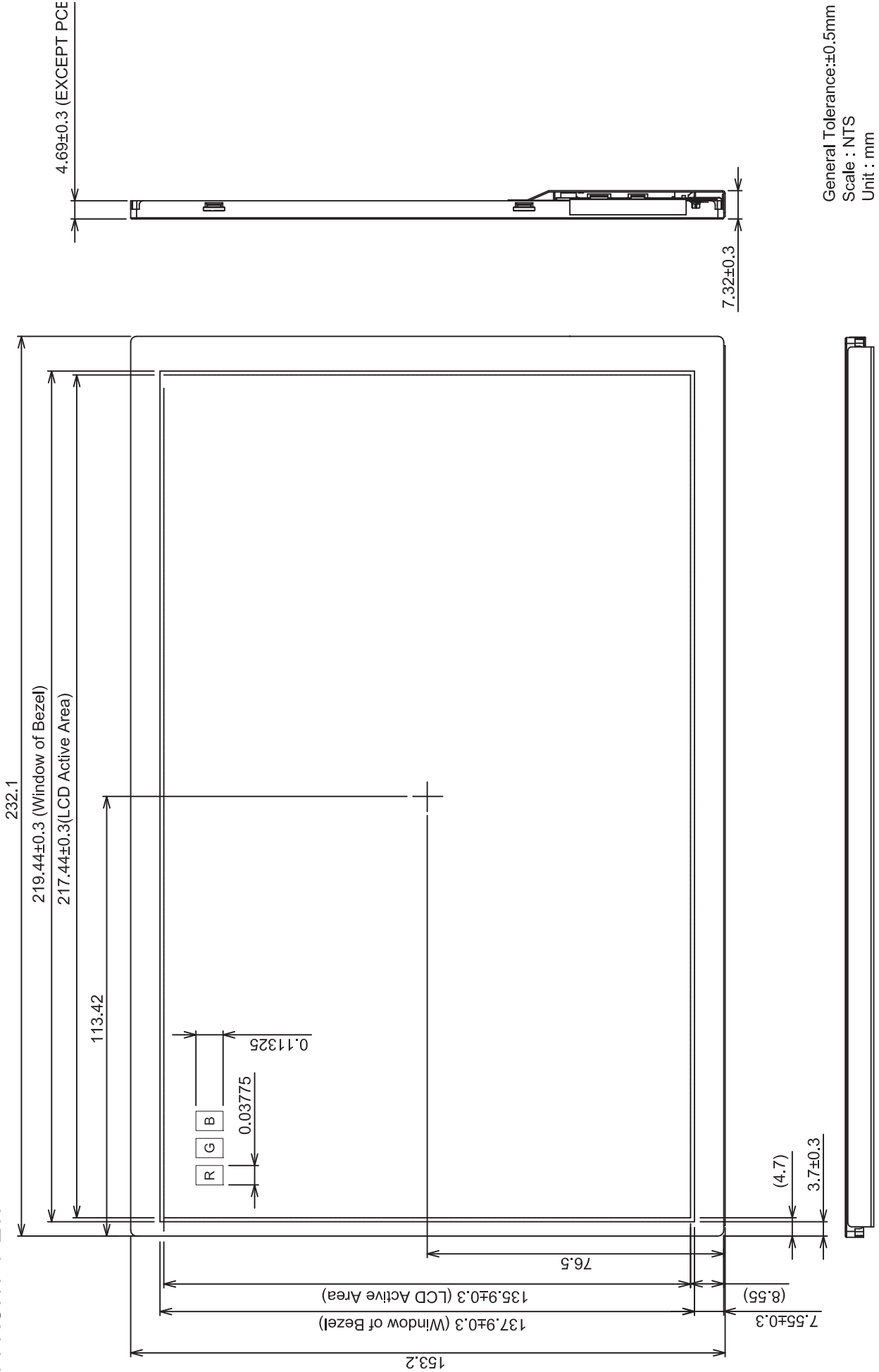

General Tolerance:±0.5mm  
Scale : NTS  
Unit : mm

10.2 REAR VIEW

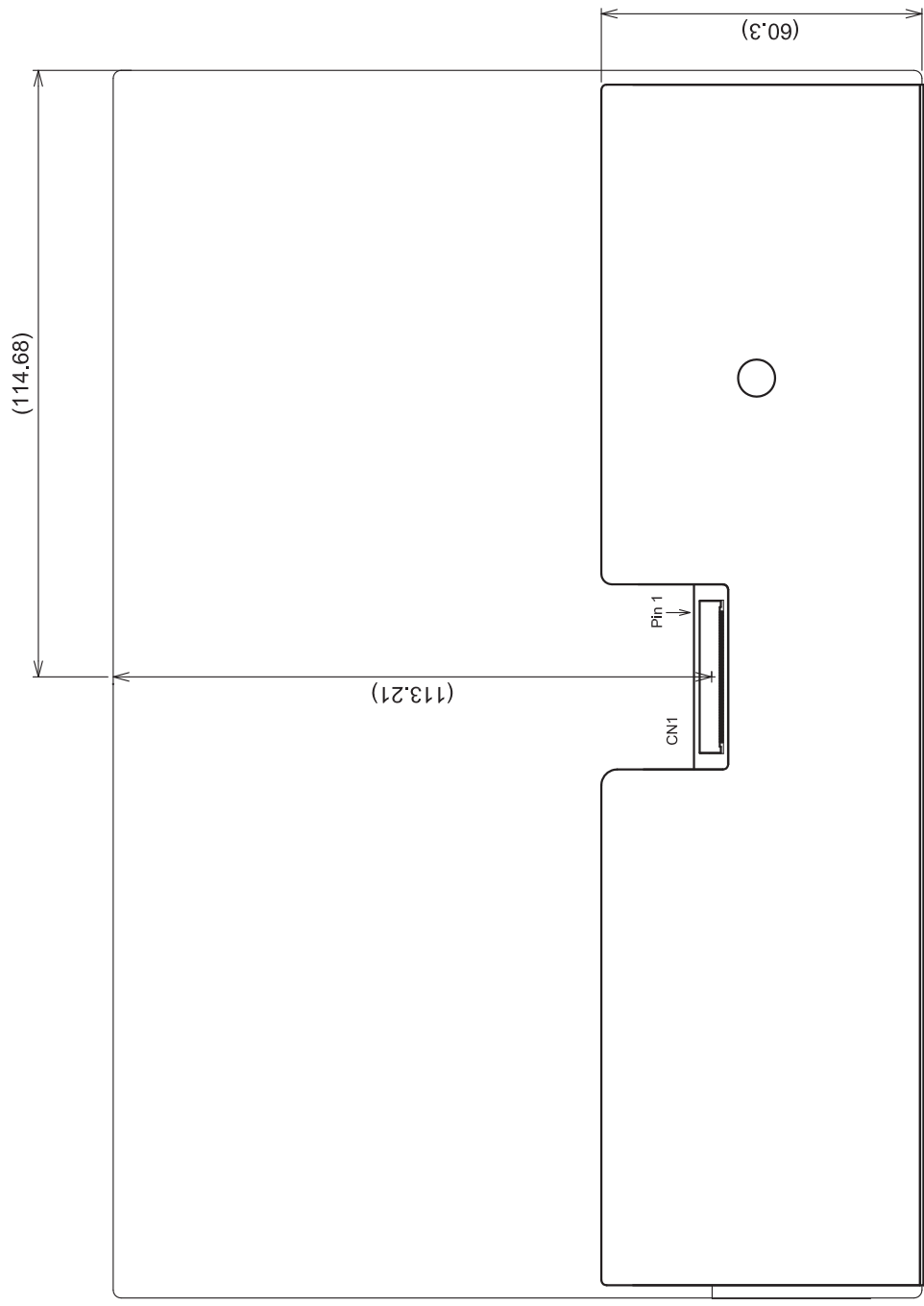

General Tolerance: ±0.5mm  
Scale : NTS  
Unit : mm

## 11. APPEARANCE STANDARD

The appearance inspection is performed in a dark room around 500~1000 lx based on the conditions as below:

- The distance between inspector's eyes and display is 30 cm.
- The viewing zone is defined with angle  $\theta$  shown in Fig. 11.1 The inspection should be performed within  $45^\circ$  when display is shut down. The inspection should be performed within  $5^\circ$  when display is power on.

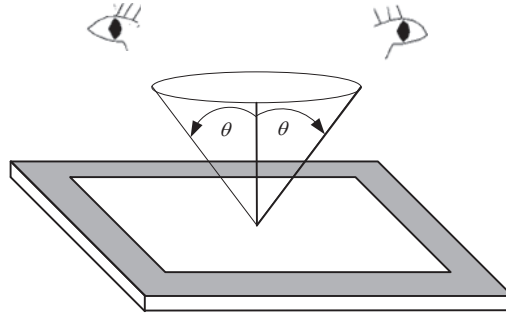

Fig. 11.1

### 11.1 THE DEFINITION OF LCD ZONE

LCD panel is divided into 2 areas as shown in Fig.11.2 for appearance specification in next section. A zone is the LCD active area (dot area); B zone is the area between A zone and metal frame.

In terms of housing design, B zone is the recommended window area customers' housing should be located in.

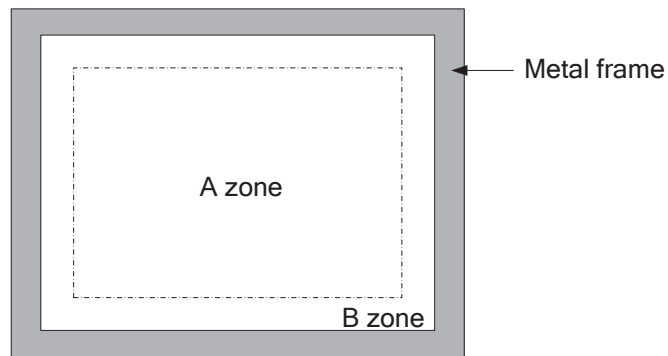

Fig. 11.2

## 11.2 LCD APPEARANCE SPECIFICATION

The specification as below is defined as the amount of unexpected phenomenon or material in different zones of LCD panel. The definitions of length, width and average diameter using in the table are shown in Fig. 11.4 and Fig. 11.5.

Item	Criteria				Applied zone
	Length (mm)	Width (mm)	Maximum number	Minimum space	
Scratches	$L \leq 15$	$W \leq 0.02$	Ignored	-	A
	$L \leq 15$	$0.02 < W \leq 0.1$	5	-	
	$L > 15$	$0.1 < W$	0	-	
	Serious one is not allowed				
Dent	Serious one is not allowed				A
Wrinkles in polarizer	Serious one is not allowed				A
Bubbles on polarizer	Average diameter (mm)		Maximum number		A
	$D < 0.3$		Ignored		
	$0.3 \leq D \leq 0.6$		4		
	$0.6 < D$		0		
1) Stains 2) Foreign Materials 3) Dark Spot	Filamentous (Line shape)				A
	Length (mm)	Width (mm)	Maximum number		
	$L \leq 2.0$	$W \leq 1.5$	5		
	$L > 2.0$	$1.5 < W$	0		A
	Round (Dot shape)				
	Average diameter (mm)		Maximum number	Minimum Space	
	$D \leq 0.2$		Ignored	-	
	$0.2 < D \leq 0.6$		4	-	
	$0.6 < D$		0	-	
	Those wiped out easily are acceptable				
Dot-Defect		Area①	Area②	Maximum number	A (Note 1)
	Bright dot-defect	0 dot	2 dot	2 dot	
	Dark dot-defect	2 dot	3 dot	3 dot	
	Bright + Dark point	2 dot	3 dot	4 dot	

Note 1: The Dot-Defect inspection within A zone (active area) would be divided into area ①, ② as Fig. 11.3 shown.

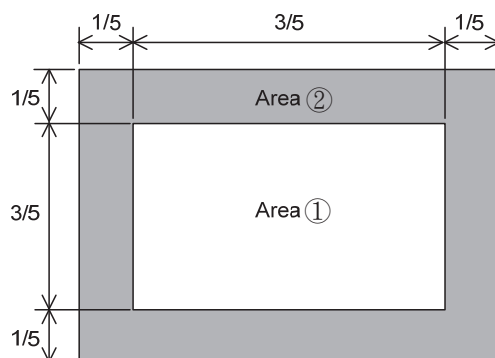

Fig. 11.3

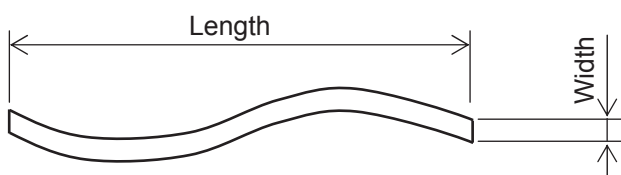
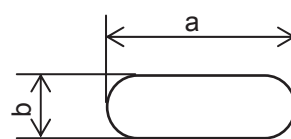

Fig 11.4



$$\text{Average diameter} = \frac{a+b}{2}$$

Fig 11.5

## 12. PRECAUTIONS

### 12.1 PRECAUTIONS of ESD

- 1) Before handling the display, please ensure your body has been connected to ground to avoid any damages by ESD. Also, do not touch display's interface directly when assembling.
- 2) Please remove the protection film very slowly before turning on the display to avoid generating ESD.

### 12.2 PRECAUTIONS of HANDLING

- 1) In order to keep the appearance of display in good condition; please do not rub any surfaces of the displays by sharp tools harder than 3H, especially touch panel, metal frame and polarizer.
- 2) Please do not pile the displays in order to avoid any scars leaving on the display. In order to avoid any injuries, please pay more attention for the edges of glasses and metal frame, and wear finger cots to protect yourself and the display before working on it.
- 3) Touching the display area or the terminal pins with bare hand is prohibited. This is because it will stain the display area and cause poor insulation between terminal pins, and might affect display's electrical characteristics furthermore.
- 4) Do not use any harmful chemicals such as acetone, toluene, and isopropyl alcohol to clean display's surfaces.
- 5) Please use soft cloth or absorbent cotton with ethanol to clean the display by gently wiping. Moreover, when wiping the display, please wipe it by horizontal or vertical direction instead of circling to prevent leaving scars on the display's surface, especially polarizer.
- 6) Please wipe any unknown liquids immediately such as saliva, water or dew on the display to avoid color fading or any permanently damages.
- 7) Maximum pressure to the surface of the display must be less than  $1,96 \times 10^4$  Pa. If the area of adding pressure is less than  $1 \text{ cm}^2$ , the maximum pressure must be less than 1.96N.

### 12.3 PRECAUTIONS OF OPERATING

- 1) Please input signals and voltages to the displays according to the values defined in the section of electrical characteristics to obtain the best performance. Any voltages over than absolute maximum rating will cause permanent damages to this display. Also, any timing of the signals out of this specification would cause unexpected performance.
- 2) When the display is operating at significant low temperature, the response time will be slower than it at  $25 \text{ C}^\circ$ . In high temperature, the color will be slightly dark and blue compared to original pattern. However, these are temperature-related phenomenon of LCD and it will not cause permanent damages to the display when used within the operating temperature.
- 3) The use of screen saver or sleep mode is recommended when static images are likely for long periods of time. This is to avoid the possibility of image sticking.
- 4) Spike noise can cause malfunction of the circuit. The recommended limitation of spike noise is no bigger than  $\pm 100 \text{ mV}$ .



## 12.4 PRECAUTIONS of STORAGE

If the displays are going to be stored for years, please be aware the following notices.

- 1) Please store the displays in a dark room to avoid any damages from sunlight and other sources of UV light.
- 2) The recommended long-term storage temperature is between 10 C° ~35 C° and 55%~75% humidity to avoid causing bubbles between polarizer and LCD glasses, and polarizer peeling from LCD glasses.
- 3) It would be better to keep the displays in the container, which is shipped from USMP, and do not unpack it.
- 4) Please do not stick any labels on the display surface for a long time, especially on the polarizer.

## 13. DESIGNATION of LOT MARK