

TFT SPECIFICATION

Part Number	USMP-T057-032024NAV-A0
Size	5.7"
Resolution	320 x 240
Brightness	490 cd/m ²
Contrast	350:1
Viewing Angle	70/70/50/70
Operating Temp.	-20 ~ 70°C

FOR ADDITIONAL INFORMATION
PLEASE CONTACT:
engineering@usmicroproducts.com

Issue Date	Approved by (customer use)	Checked by	Prepared by

PROPRIETARY NOTE: THIS SPECIFICATION IS THE PROPERTY OF US MICRO PRODUCTS AND SHALL NOT BE REPRODUCED OR COPIED WITHOUT THE WRITTEN PERMISSION OF US MICRO PRODUCTS AND MUST BE RETURNED TO US MICRO PRODUCTS UPON ITS REQUEST.

(800) 741-7755
www.usmicroproducts.com

Table of Contents

1. COVER & CONTENTS	1
2. RECORD OF REVISION	2
3. APPLICATION.....	3
4. GENERAL SPECIFICATIONS	3
5. ABSOLUTE MAXIMUM RATINGS	3
6. ELECTRICAL CHARACTERISTICS	3
7. BLOCK DIAGRAM	4
8. PIN CONNECTIONS	5
9. INTERFACE SPECIFICATIONS	6
10. OPTICAL CHARACTERISTIC	11
11. QUALITY ASSURANCE	14
12. LCM PRODUCT LABEL DEFINE	15
13. PRECAUTIONS IN USE LCM	17
14. OUTLINE DRAWING	18
15. PACKAGE INFORMATION	19

2. RECORD OF REVISION

Rev	Date	Item	Page	Comment
1	25/JUL/07			Initial preliminary
A	5/SEP/07	4,6,10, 15	3,10,16	1.Add Weight. 2.Add Power Supply Current for LCD. 3.Add Power Supply Current for LED. 4.Add LED life time 25000 hours(typ.). 5.Add Chromaticity data. 6.Change OUTLINE DRAWING.
B	29/NOV/07	6,16	3,17	1. Modify LED life time 25000hours to LED Dice life time 50000hours. 2. Change Note1, ambient temperature: from 25°C to 22°C . 3. Change PACKAGE INFORMATION.
C	31/MAR/08	9.2	9	Add DE Only mode timing
D	27/MAY/08	9.2,10, 15	9,11,17	Release Rev: A for Production. 1. Remove DE only mode timing, and add SYNC mode timing. 2. Modify chromaticity data. 3. Change OUTLINE DRAWING rev:1 to A.
E	6/AUG/08	15	17	Modify: OUTLINE DRAWING
F	12/OCT/10'	4 12 14	3 15 18	1.Modify Surface treatment 2.Revise LCM PRODUCT LABEL DEFINE 3.Modify OUTLINE DRAWING from rev. B to C
G	5/MAY/10'	4 14	3 18	1. Modify thickness from 9.7MAX to 9.2MAX 2. Modify OUTLINE DRAWING from Rev. C to D

3. APPLICATION

Digital equipments which need color display, such as P.O.S, medical equipments and industrial equipments.

4. GENERAL SPECIFICATIONS

Parameter	Specifications	Unit
Display resolution	(320X R.G.B) (W) x 240(H)	dot
Active area	115.2(W) x 86.4(H)	mm
Screen size	5.7(Diagonal)	inch
Dot pitch	0.12(W) x 0.36(H)	mm
Color configuration	R.G.B. Stripe	
Overall dimension	127 (W) x 98.43(H) x 9.2Max.(T)	mm
Weight	110	g
Surface treatment	Anti-Glare	
View Angle direction	6 o'clock	
Our components and processes are compliant to RoHS standard		

5. ABSOLUTE MAXIMUM RATINGS

Parameter	Symbol	MIN.	MAX.	Unit	Remark
Power supply voltage	V _{CC}	-0.3	5.0	V	
Logic input voltage	V _I	-0.3	V _{CC} +0.3	V	
Operating temperature	Top	-20	+70	°C	Ambient temperature
Storage temperature	T _{st}	-30	+80	°C	Ambient temperature

6. ELECTRICAL CHARACTERISTICS

GND=0V, CLK1=7.21MHz, Ta=25°C

Parameter	Symbol	MIN.	Typ.	MAX.	Unit	Remark
Power Supply voltage for LCD	V _{CC}	+3.0	+3.3	+3.6	V	
Power Supply Current for LCD	I _{CC}		62	80	mA	V _{CC} =3.3V
Power Supply voltage for LED	V _{LED}	4.5	5	5.5	V	
Power Supply Current for LED	I _{LED}		333	400	mA	V _{LED} =5.0V
Ripple voltage	V _{RF}	-	-	100	mV _{P-P}	
“H” level logical input voltage	V _{IH}	0.7V _{CC}	--	V _{CC}	V	
“L” level logical input voltage	V _{IL}	0	--	0.3V _{CC}	V	
ADJ frequency		19K	20K	21K	Hz	
ADJ input voltage	V _{IH}	3.0	-	3.3	V	
	V _{IL}	0	-	0.3	V	
LED Dice life time		-	50000	-	Hr	Note 1

Note 1: The “LED dice life time” is defined as the brightness decrease to 50% original brightness that the ambient temperature is 22°C and LED dice current=20mA.

7. BLOCK DIAGRAM

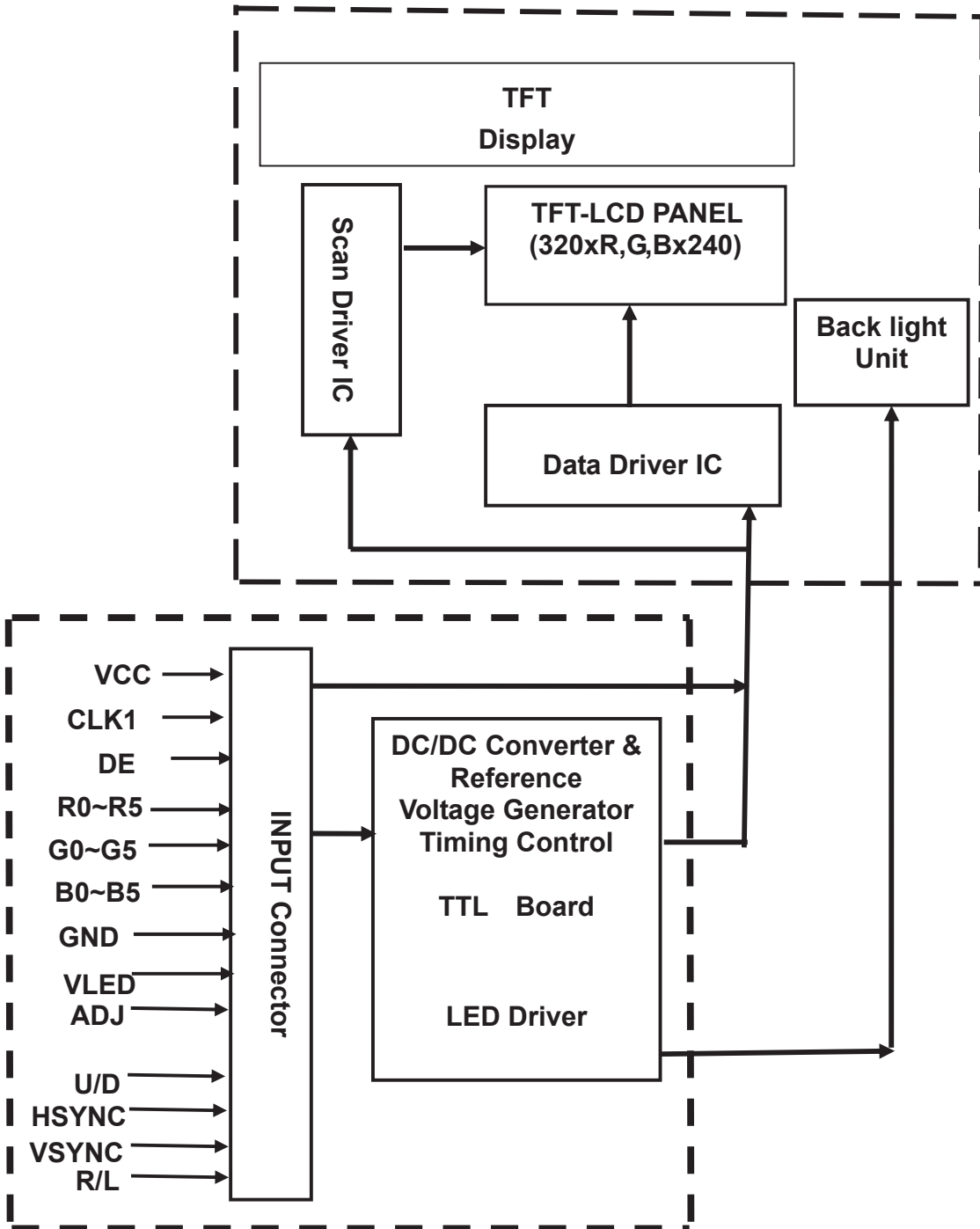

8. PIN CONNECTIONS

8.1 CN1 Pins Connections

Pin No	Symbol	Function	Remark
1	GND	Ground for logic circuit	
2	CLK1	Data sampling clock	
3	HS (HSYNC)	Horizontal synchronous signal	
4	VS (VSYNC)	Vertical synchronous signal	
5	GND	Ground	
6	R0	Red pixel data(LSB)	
7	R1	Red pixel data	
8	R2	Red pixel data	
9	R3	Red pixel data	
10	R4	Red pixel data	
11	R5	Red pixel data(MSB)	
12	GND	Ground	
13	G0	Green pixel data(LSB)	
14	G1	Green pixel data	
15	G2	Green pixel data	
16	G3	Green pixel data	
17	G4	Green pixel data	
18	G5	Green pixel data(MSB)	
19	GND	Ground	
20	B0	Blue pixel data(LSB)	
21	B1	Blue pixel data	
22	B2	Blue pixel data	
23	B3	Blue pixel data	
24	B4	Blue pixel data	
25	B5	Blue pixel data(MSB)	
26	GND	Ground for logic circuit	
27	DE	Data Enable (connected to GND, if sync mode)	
28	Vcc	Power Supply : +3.3V	
29	Vcc	Power Supply : +3.3V	
30	R/L	Horizontal display mode select signal Left / Right Scan control input	*2
31	U/D	Vertical display mode select signal Up / Down Scan control input	*2
32	NC	No Connection	
33	GND	Ground	

*1 The horizontal display start timing is settled in accordance with a rising timing of DE signal. In case DE is fixed "Low", the horizontal start timing is determined as described in 9.2. Don't keep DE "High" during operation.

*2 U/D and L/R control Function

L/R	U/D	Function
0	1	Normally display
1	1	Left and Right opposite
0	0	Up and Down opposite
1	0	Left and Right opposite , Up and Down opposite

8.2. CN2 Pins Connections

Pin No.	Symbol	Function	Remark
1	VLED	Power supply for LED driver circuit	
2	GND	Ground	
3	ADJ	Brightness control for LED B/L	

*ADJ is brightness control pin. The larger of the pulse duty is, higher of the brightness.

9. INTERFACE SPECIFICATIONS

9.1 Input Signal Timing Specifications

Parameter		Symbol	MIN.	TYP.	MAX.	Unit	Remarks
CLK	Frequency	1/Tc		7.21		MHz	
	Duty ratio	Th/Tc	40	50	60	%	
DATA	Setup time	Tds	12			ns	
	Hold time	Tdh	12			ns	
Horizontal synchronizing	Period	TH	--	453	--	Clock	
	Pulse width	THp	--	31	--	Clock	
	Horizontal period	THd	--	320	--	Clock	
	Back porch	THb	--	69	--	Clock	
	Front porch	THf	--	33	--	Clock	
Vertical synchronizing	Period	TV	--	267	--	Line	
	Pulse width	TVp	--	6	--	Line	
	Vertical period	TVd	--	240	--	Line	
	Back porch	TVb	--	18	--	Line	
	Front porch	TVf	--	3	--	Line	

Note:

- ◇ In case of using the slow frequency, the deterioration of display flicker etc may occur.
- ◇ The timing characteristics are basically fixed as above.

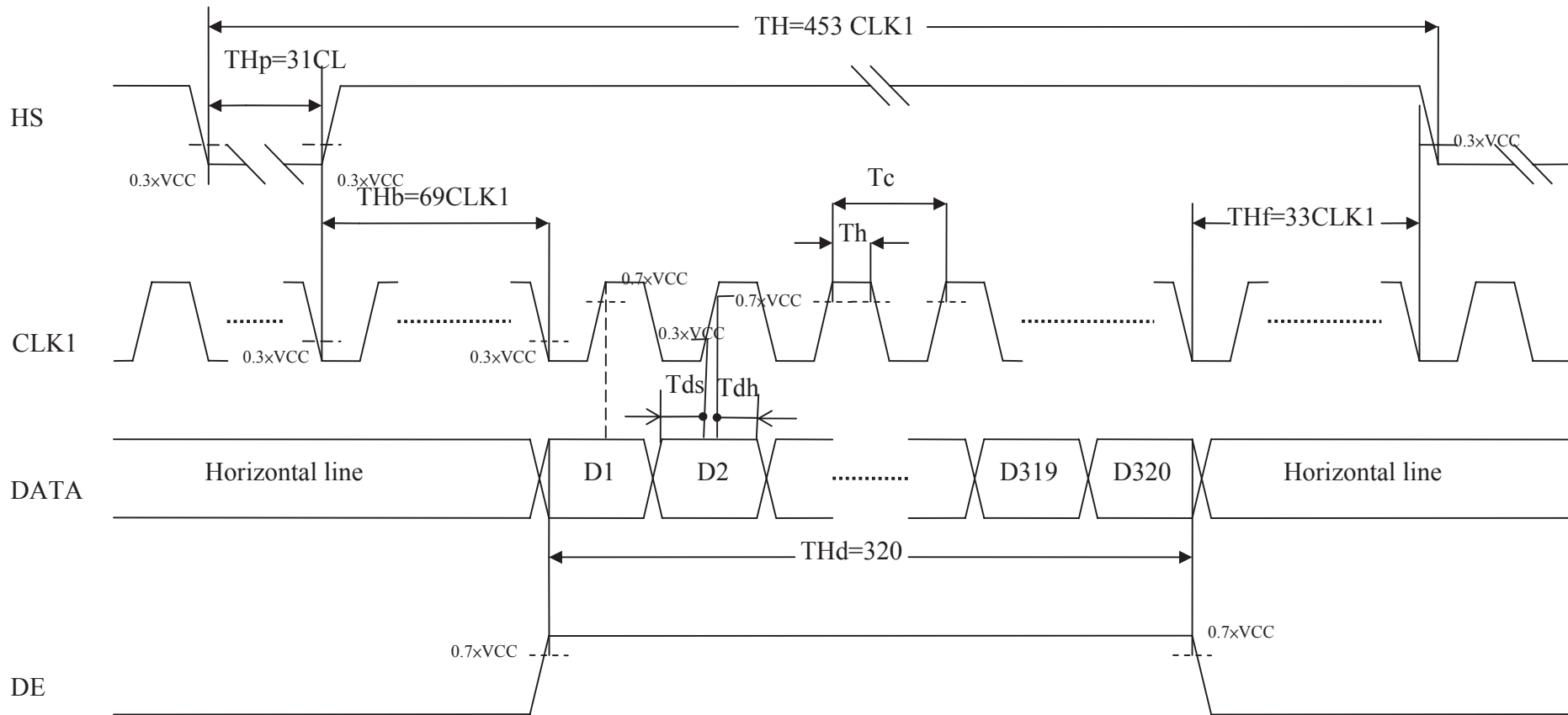

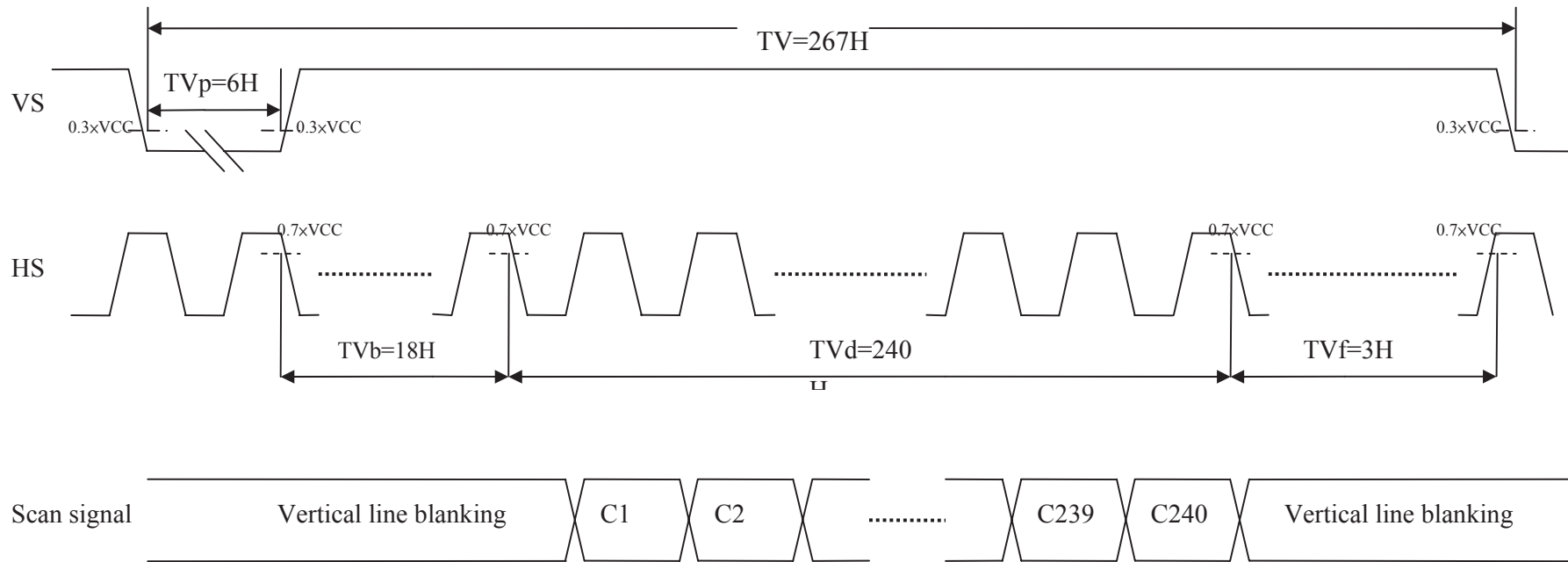

9.2 SYNC mode timing (DE connect to GND)

Parameter		Symbol	MIN.	TYP.	MAX.	Unit	Remarks
CLK	Frequency	1/Tc		6.41		MHz	
	Duty ratio	Th/Tc	40	50	60	%	
DATA	Setup time	Tds	12			ns	
	Hold time	Tdh	12			ns	
Horizontal synchronizing	Period	TH	--	408	--	Clock	
	Pulse width	THp	--	30	--	Clock	
	Horizontal period	THd	--	320	--	Clock	
	Back porch	THb	--	38	--	Clock	
	Front porch	THf	--	20	--	Clock	
Vertical synchronizing	Period	TV	--	262	--	Line	
	Pulse width	TVp	--	4	--	Line	
	Vertical period	TVd	--	240	--	Line	
	Back porch	TVb	--	15	--	Line	
	Front porch	TVf	--	3	--	Line	

Note:

- ✧ In case of using the slow frequency, the deterioration of display flicker etc may occur.
- ✧ The timing characteristics are basically fixed as above.

9.3 Power Off/On Sequence Timing

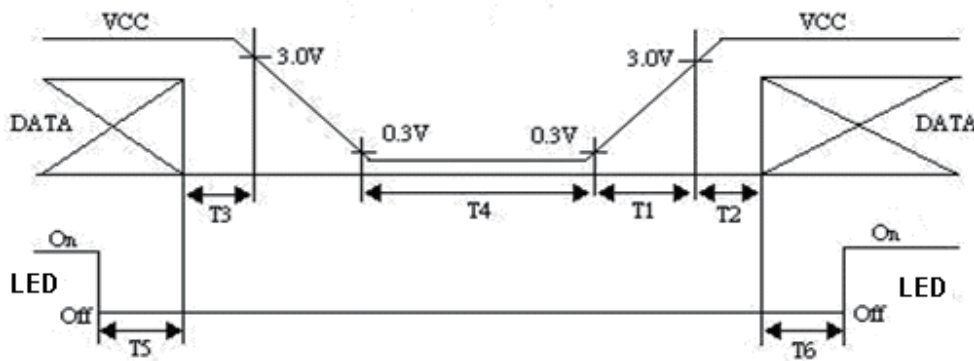

Timing Specifications:

- 0 < T1 ≤ 15mS
- T2 > 0.5S
- 0 < T3 ≤ 0.1S
- T4 > 1S
- T5 > 0.1S
- T6 > 0.1S

9.4 Color Data Input Assignment

		Data Signal																	
		Red					Green					Blue							
Color		R5	R4	R3	R2	R1	R0	G5	G4	G3	G2	G1	G0	B5	B4	B3	B2	B1	B0
Basic Colors	Black	0	0	0	0	0	0	0	0	0	0	0	0	0	0	0	0	0	0
	Red	1	1	1	1	1	1	0	0	0	0	0	0	0	0	0	0	0	0
	Green	0	0	0	0	0	0	1	1	1	1	1	1	0	0	0	0	0	0
	Blue	0	0	0	0	0	0	0	0	0	0	0	0	1	1	1	1	1	1
	Cyan	0	0	0	0	0	0	1	1	1	1	1	1	1	1	1	1	1	1
	Magenta	1	1	1	1	1	1	0	0	0	0	0	0	1	1	1	1	1	1
	Yellow	1	1	1	1	1	1	1	1	1	1	1	1	0	0	0	0	0	0
	White	1	1	1	1	1	1	1	1	1	1	1	1	1	1	1	1	1	1
Gray Scale of Red	Red(0) / Dark	0	0	0	0	0	0	0	0	0	0	0	0	0	0	0	0	0	0
	Red(1)	0	0	0	0	0	1	0	0	0	0	0	0	0	0	0	0	0	0
	Red(2)	0	0	0	0	1	0	0	0	0	0	0	0	0	0	0	0	0	0
	:	:	:	:	:	:	:	:	:	:	:	:	:	:	:	:	:	:	:
	:	:	:	:	:	:	:	:	:	:	:	:	:	:	:	:	:	:	:
	Red(61)	1	1	1	1	0	1	0	0	0	0	0	0	0	0	0	0	0	0
	Red(62)	1	1	1	1	1	0	0	0	0	0	0	0	0	0	0	0	0	0
	Red(63)	1	1	1	1	1	1	0	0	0	0	0	0	0	0	0	0	0	0
Gray Scale of Green	Green(0)/ Dark	0	0	0	0	0	0	0	0	0	0	0	0	0	0	0	0	0	0
	Green(1)	0	0	0	0	0	0	0	0	0	0	0	1	0	0	0	0	0	0
	Green(2)	0	0	0	0	0	0	0	0	0	0	1	0	0	0	0	0	0	0
	:	:	:	:	:	:	:	:	:	:	:	:	:	:	:	:	:	:	:
	:	:	:	:	:	:	:	:	:	:	:	:	:	:	:	:	:	:	:
	Green(61)	0	0	0	0	0	0	1	1	1	1	0	1	0	0	0	0	0	0
	Green(62)	0	0	0	0	0	0	1	1	1	1	1	0	0	0	0	0	0	0
	Green(63)	0	0	0	0	0	0	1	1	1	1	1	1	0	0	0	0	0	0
Gray Scale of Blue	Blue(0)/ Dark	0	0	0	0	0	0	0	0	0	0	0	0	0	0	0	0	0	0
	Blue (1)	0	0	0	0	0	0	0	0	0	0	0	0	0	0	0	0	0	1
	Blue (2)	0	0	0	0	0	0	0	0	0	0	0	0	0	0	0	0	1	0
	:	:	:	:	:	:	:	:	:	:	:	:	:	:	:	:	:	:	:
	:	:	:	:	:	:	:	:	:	:	:	:	:	:	:	:	:	:	:
	Blue (61)	0	0	0	0	0	0	0	0	0	0	0	0	1	1	1	1	0	1
	Blue (62)	0	0	0	0	0	0	0	0	0	0	0	0	1	1	1	1	1	0
	Blue (63)	0	0	0	0	0	0	0	0	0	0	0	0	1	1	1	1	1	1

Correspondence between Data and Display Position

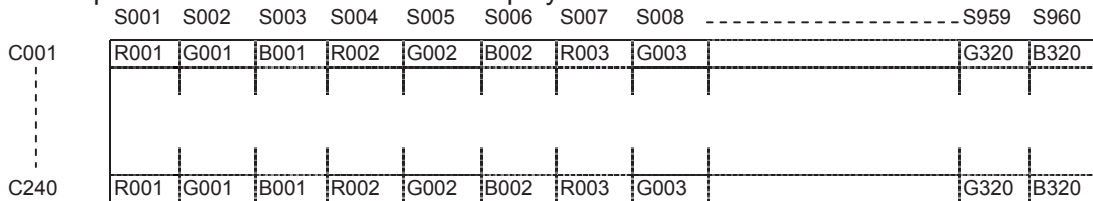

10. OPTICAL CHARACTERISTIC

Parameter	Symbol	Condition	MIN.	TYP.	MAX.	Unit	Remarks	
Viewing Angle	Horizontal	θ_{x+}	60	70	--	deg	Note 1,4	
		θ_{x-}	60	70	--			
	Vertical	θ_{y+}	CR \geq 5	40	50			--
		θ_{y-}		60	70			--
Contrast Ratio	CR	at optimized viewing angle	300	350			Note 1,3	
Response time	Rise	Tr	-	15	30	ms	Note 1,6	
	Fall	Tf	-	35	50	ms		
Uniformity		B-uni	$\theta_{x=\theta y}=0^{\circ}$	70	80	--	%	Note1,5
Brightness		L	$\theta_{x=\theta y}=0^{\circ}$ ADJ=3.3V	440	490	--	cd/m ²	Note 1,2
Chromaticity	x_W	Center $\theta_{x=\theta y}=0^{\circ}$	0.262	0.312	0.362		Note 1,7	
	y_W		0.270	0.320	0.370			
	x_R		0.568	0.618	0.668			
	y_R		0.319	0.369	0.419			
	x_G		0.301	0.351	0.401			
	y_G		0.521	0.571	0.621			
	x_B		0.094	0.144	0.194			
	y_B		0.031	0.081	0.131			
Image sticking	tis	2 hours			2	Sec	Note 8	

The following optical specifications shall be measured in a darkroom or equivalent state (ambient luminance ≤ 1 lux, and at room temperature). The operation temperature is $25^{\circ}\text{C} \pm 2^{\circ}\text{C}$. The measurement method is shown in Note1.

Note1: The method of optical measurement:

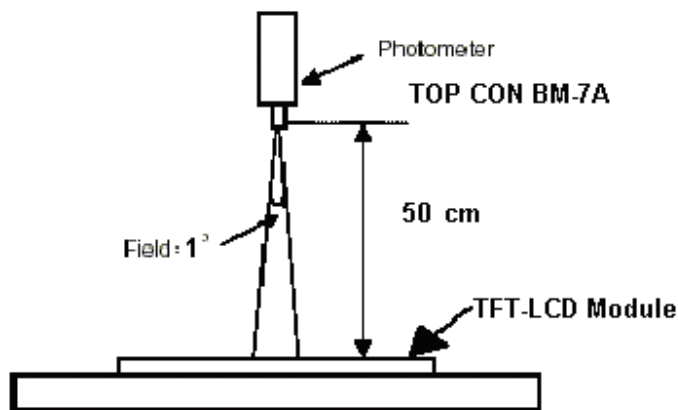

Note2: Measured at the center area of the panel and at the viewing angle of the $\theta_x = \theta_y = 0^\circ$

Note3: Definition of Contrast Ratio (CR):

$$CR = \frac{\text{Luminance with all pixels in white state}}{\text{Luminance with all pixels in Black state}}$$

Note4: Definition of Viewing Angle

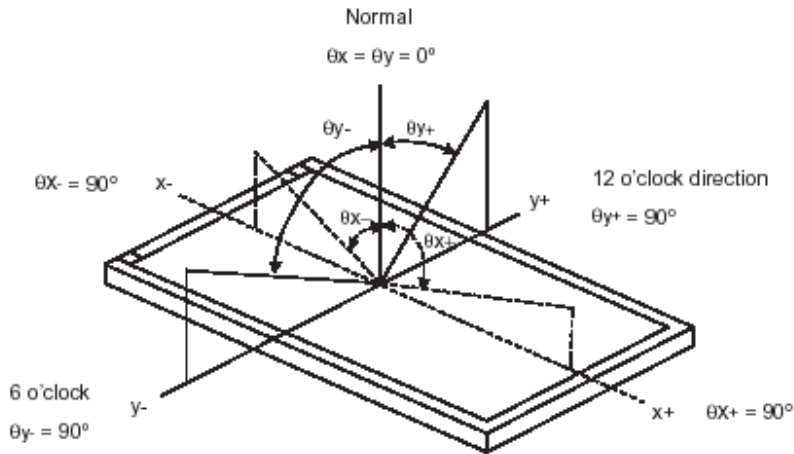

Note 5: Definition of Brightness Uniformity (B-uni):

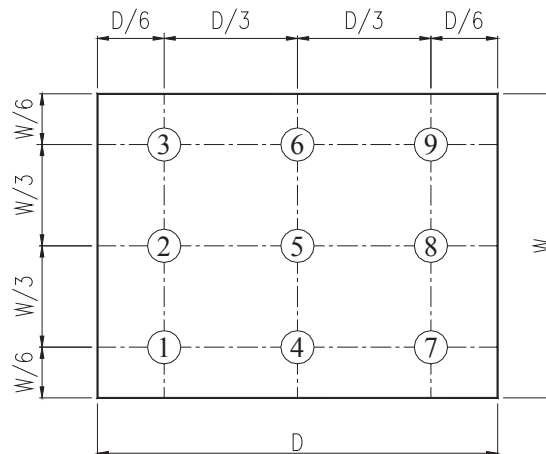

$$B\text{-uni} = \frac{\text{Minimum luminance of 9 points}}{\text{Maximum luminance of 9 points}} \quad (\text{Note 5}).$$

Note6: Definition of Response Time:

The Response Time is set initially by defining the "Rising Time (Tr)" and the "Falling Time (Tf)" respectively. Tr and Tf are defined as following figure.

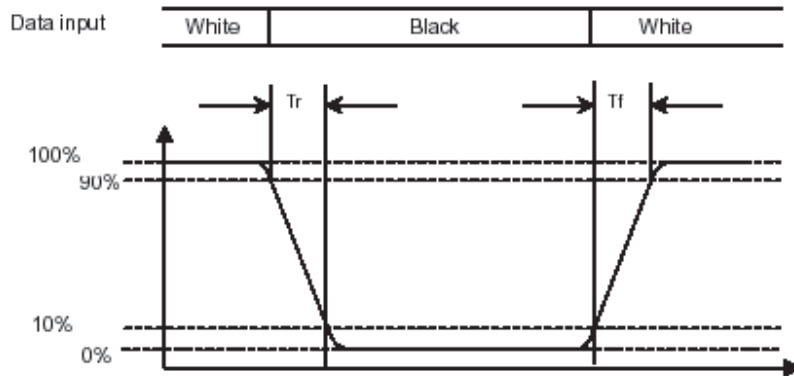

Note 7: Definition of Chromaticity:

The color coordinates (x_w, y_w) , (x_r, y_r) , (x_g, y_g) , and (x_b, y_b) are obtained with all pixels in the viewing field at white, red, green, and blue states, respectively.

Note 8: Definition of Image sticking (tis):

Continuously display the test pattern shown in the figure below for 2 hours. Then display a completely white screen. The previous image shall not persist more than 2 sec at 25 °C

Image sticking pattern

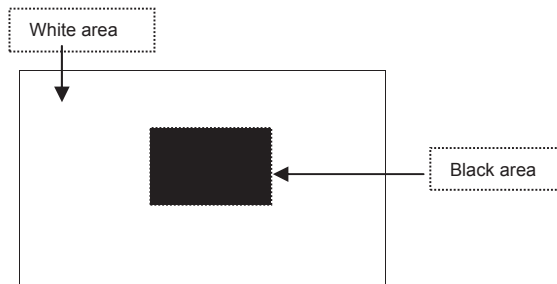

11. QUALITY ASSURANCE

11.1 Test Condition

11.1.1 Temperature and Humidity(Ambient Temperature)

Temperature : $25 \pm 5^{\circ}\text{C}$

Humidity : $65 \pm 5\%$

11.1.2 Operation

Unless specified otherwise, test will be conducted under function state.

11.1.3 Container

Unless specified otherwise, vibration test will be conducted to the product itself without putting it in a container.

11.1.4 Test Frequency

In case of related to deterioration such as shock test. It will be conducted only once.

11.1.5 Test Method

No.	Reliability Test Item & Level	Test Level
1	High Temperature Storage Test	T=80°C,240hrs
2	Low Temperature Storage Test	T=-30°C,240hrs
3	High Temperature Operation Test	T=70°C,240hrs
4	Low Temperature Operation Test	T=-20°C,240hrs
5	High Temperature and High Humidity Operation Test	T=60°C,90% RH,240hrs
6	Thermal Cycling Test (No operation)	-30°C → +25°C → +80°C,200 Cycles 30 min 5min 30 min
7	Vibration Test (No operation)	Frequency:0 ~ 55 Hz Amplitude:1.5 mm Sweep Time:11min Test Period:6 Cycles for each Direction of X,Y,Z
8	Electrostatic Discharge Test (No operation)	150pF,330Ω Air:± 15KV;Contact: ± 8KV 10 times/point;4 points/panel face

12.LCM PRODUCT LABEL DEFINE

Product Name Define:

13. PRECAUTIONS IN USE LCM

1. LIQUID CRYSTAL DISPLAY (LCD)

LCD is made up of glass, organic sealant, organic fluid, and polymer based polarizers. The following precautions should be taken when handling,

- (1). Keep the temperature within range of use and storage. Excessive temperature and humidity could cause polarization degradation, polarizer peel off or bubble.
- (2). Do not contact the exposed polarizers with anything harder than an HB pencil lead. To clean dust off the display surface, wipe gently with cotton, chamois or other soft material soaked in petroleum benzin.
- (3). Wipe off saliva or water drops immediately. Contact with water over a long period of time may cause polarizer deformation or color fading, while an active LCD with water condensation on its surface will cause corrosion of ITO electrodes.
- (4). Glass can be easily chipped or cracked from rough handling, especially at corners and edges.
- (5). Do not drive LCD with DC voltage.

2. Liquid Crystal Display Modules

2.1 Mechanical Considerations

LCM are assembled and adjusted with a high degree of precision. Avoid excessive shocks and do not make any alterations or modifications. The following should be noted.

- (1). Do not tamper in any way with the tabs on the metal frame.
- (2). Do not modify the PCB by drilling extra holes, changing its outline, moving its components or modifying its pattern.
- (3). Do not touch the elastomer connector, especially insert an backlight panel (for example, EL).
- (4). When mounting a LCM make sure that the PCB is not under any stress such as bending or twisting. Elastomer contacts are very delicate and missing pixels could result from slight dislocation of any of the elements.
- (5). Avoid pressing on the metal bezel, otherwise the elastomer connector could be deformed and lose contact, resulting in missing pixels.

2.2. Static Electricity

LCM contains CMOS LSI's and the same precaution for such devices should apply, namely

- (1). The operator should be grounded whenever he/she comes into contact with the module. Never touch any of the conductive parts such as the LSI pads, the copper leads on the PCB and the interface terminals with any parts of the human body.
- (2). The modules should be kept in antistatic bags or other containers resistant to static for storage.
- (3). Only properly grounded soldering irons should be used.
- (4). If an electric screwdriver is used, it should be well grounded and shielded from commutator sparks.

(5) The normal static prevention measures should be observed for work clothes and working benches; for the latter conductive (rubber) mat is recommended.

(6). Since dry air is inductive to statics, a relative humidity of 50-60% is recommended.

2.3 Soldering

- (1). Solder only to the I/O terminals.
- (2). Use only soldering irons with proper grounding and no leakage.
- (3). Soldering temperature : $280^{\circ}\text{C} \pm 10^{\circ}\text{C}$
- (4). Soldering time: 3 to 4 sec.
- (5). Use eutectic solder with resin flux fill.
- (6). If flux is used, the LCD surface should be covered to avoid flux spatters. Flux residue should be removed after wards.

2.4 Operation

- (1). The viewing angle can be adjusted by varying the LCD driving voltage V0.
- (2). Driving voltage should be kept within specified range; excess voltage shortens display life.
- (3). Response time increases with decrease in temperature.
- (4). Display may turn black or dark blue at temperatures above its operational range; this is (however not pressing on the viewing area) may cause the segments to appear "fractured".
- (5). Mechanical disturbance during operation (such as pressing on the viewing area) may cause the segments to appear "fractured".

2.5 Storage

If any fluid leaks out of a damaged glass cell, wash off any human part that comes into contact with soap and water. Never swallow the fluid. The toxicity is extremely low but caution should be exercised at all the time.

2.6 Limited Warranty

Unless otherwise agreed between USMP and customer, USMP will replace or repair any of its LCD and LCM which is found to be defective electrically and visually when inspected in accordance with USMP acceptance standards, for a period on one year from date of shipment. Confirmation of such date shall be based on freight documents. The warranty liability of USMP is limited to repair and/or replacement on the terms set forth above. USMP will not responsible for any subsequent or consequential events.

14. OUTLINE DRAWING

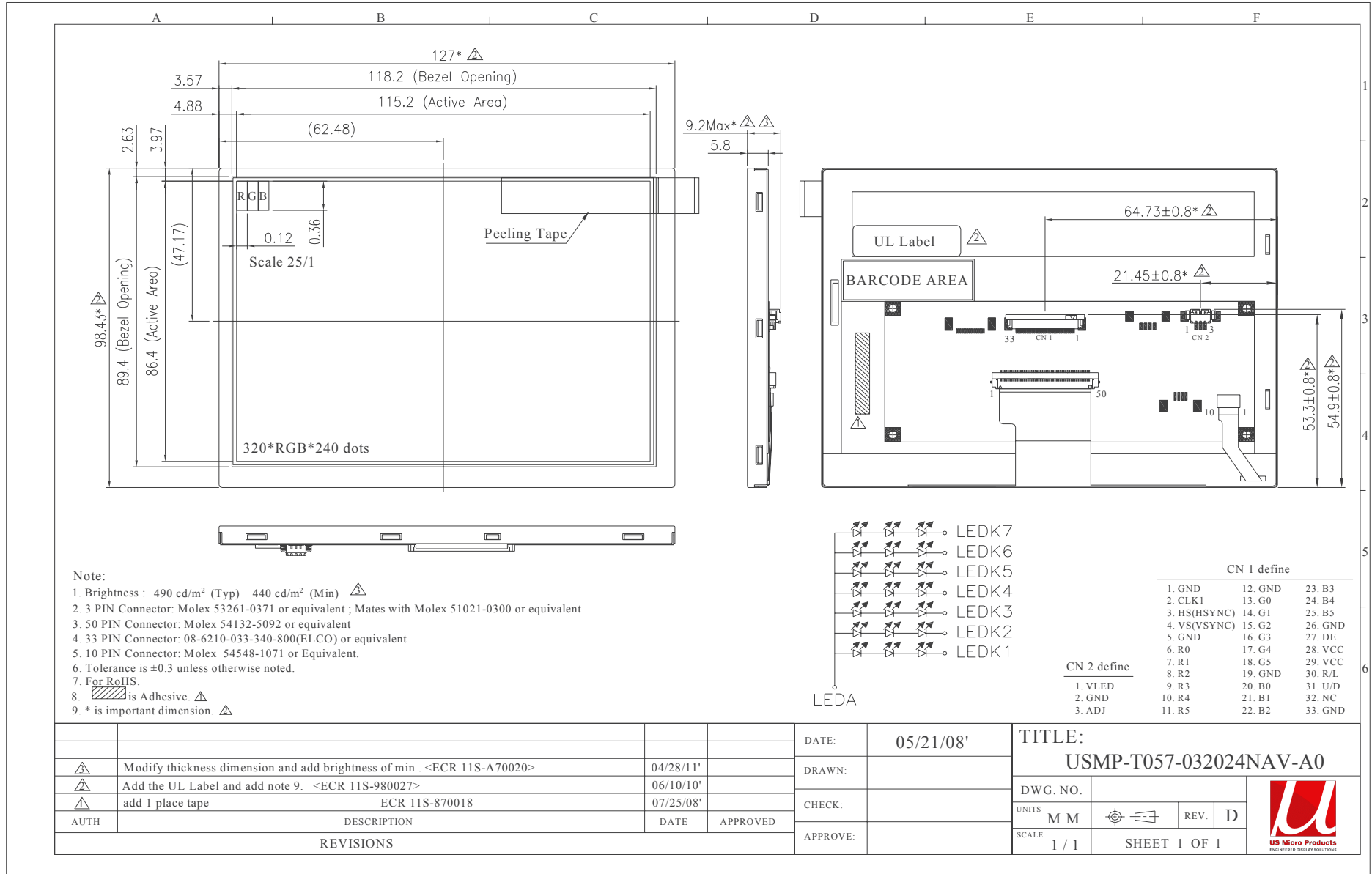

15. PACKAGE INFORMATION

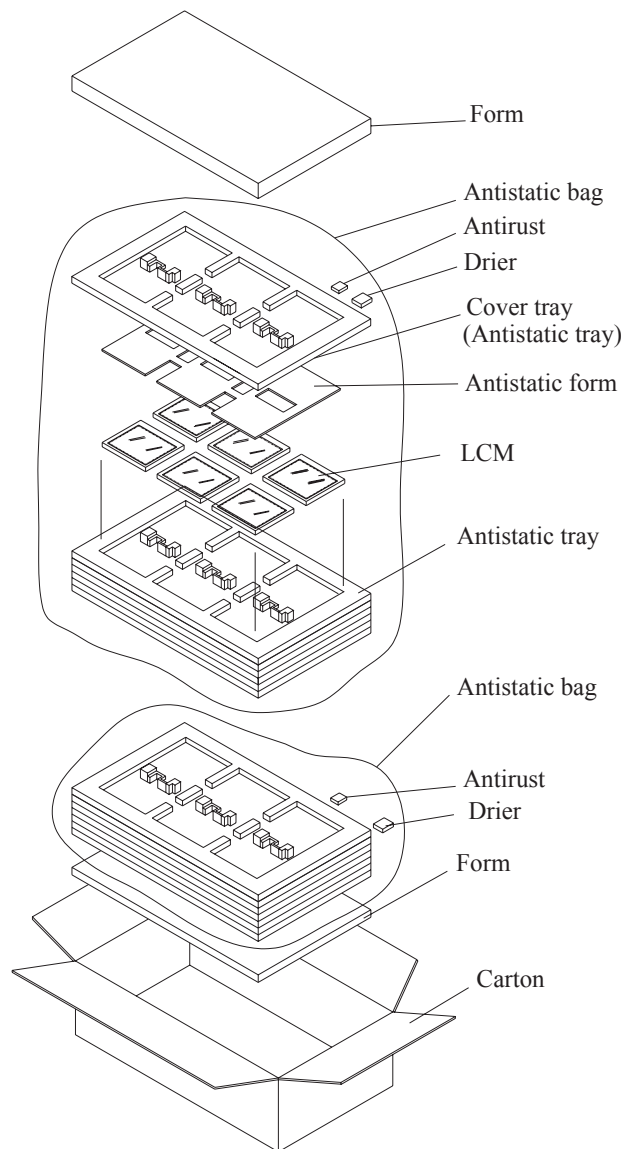

Material

1 Carton + 2 Anti-static bag + 1 Form(35mm) + 1 Form(15mm)
+ 14 Anti-static tray + 2 Drier + 2 Antirust

Total pcs

1 Antistatic tray = 6 pcs

1 Anti-static bag = 6 Anti-static tray + cover tray = $6*6 + 1*0 = 36$ pcs

1 Carton = 2 Anti-static bag = $2*36 = 72$ pcs

1 Carton = 72pcs

Carton size : 482L x 282W x 279H (mm)

Total Weight ÷ 11 kgw