



US Micro Products
Electronic Products for the OEM

OLED PRODUCT SPECIFICATION

Manufactured by:



PART NUMBER:	USMP-P19701
DESCRIPTION:	2.4", 128 x 64, Monochrome Yellow, TAB, SSD1303 IC

ISSUE DATE	APPROVED BY (Customer Use Only)	CHECKED BY	PREPARED BY
PROPRIETARY NOTE:	THIS SPECIFICATION IS THE PROPERTY OF US MICRO PRODUCTS AND SHALL NOT BE REPRODUCED OR COPIED WITHOUT THE WRITTEN PERMISSION OF US MICRO PRODUCTS AND MUST BE RETURNED TO US MICRO PRODUCTS UPON ITS REQUEST.		

REVISION RECORD

REV.	REVISION DESCRIPTION	REV. DATE	REMARK
X01	INITIAL RELEASE	2007. 07. 13	
X02	<ul style="list-style-type: none"> ■ Modify features ■ Add the operating conditions for different luminance ■ Add the panel electrical specifications ■ Add the application circuit 	2007. 08. 17	Page 4, 6, 7, 8, 13 & 14
A01	<ul style="list-style-type: none"> ■ Transfer from X version ■ Add the information of module weight ■ Modify panel electrical specifications ■ Modify external DC-DC application circuit ■ Add the packing specification 	2007. 09. 17	Page 5, 6, 8, 14 & 17

CONFIDENTIAL

CONTENTS

ITEM	PAGE
<u>1. SCOPE</u>	4
<u>2. WARRANTY</u>	4
<u>3. FEATURES</u>	4
<u>4. MECHANICAL DATA</u>	5
<u>5. MAXIMUM RATINGS</u>	6
<u>6. ELECTRICAL CHARACTERISTICS</u>	7
6.1 D.C ELECTRICAL CHARACTERISTICS	
6.2 ELECTRO-OPTICAL CHARACTERISTICS	
<u>7. INTERFACE</u>	9
7.1 FUNCTION BLOCK DIAGRAM	
7.2 PANEL LAYOUT DIAGRAM	
7.3 PIN ASSIGNMENTS	
7.4 GRAPHIC DISPLAY DATA RAM ADDRESS MAP	
7.5 INTERFACE TIMING CHART	
<u>8. APPLICATION CIRCUIT</u>	13
8.1 APPLICATION CIRCUIT	
8.2 COMMAND TABLE	
<u>9. RELIABILITY TEST CONDITIONS</u>	15
<u>10. EXTERNAL DIMENSION</u>	16
<u>11. PACKING SPECIFICATION</u>	17
<u>12. APPENDIXES</u>	18

CONFIDENTIAL

1. SCOPE

The purpose of this specification is to define the general provisions and quality requirements that apply to the supply of display cells manufactured by RiTdisplay. This document, together with the Module Assembly Drawing, is the highest-level specification for this product. It describes the product, identifies supporting documents and contains specifications, which are either not addressed, or are exceptions to the supporting documents.

2. WARRANTY

RiTdisplay warrants that the products delivered pursuant to this specification (or order) will conform to the agreed specifications for twelve (12) months from the shipping date ("Warranty Period"). RiTdisplay is obligated to repair or replace the products which are found to be defective or inconsistent with the specifications during the Warranty Period without charge, on condition that the products are stored or used as the conditions specified in the specifications. Nevertheless, RiTdisplay is not obligated to repair or replace the products without charge if the defects or inconsistency are caused by the force majeure or the reckless behaviors of the customer. After the Warranty Period, all repairs or replacements of the products are subject to charge.

3. FEATURES

- Small molecular organic light emitting diode.
- Color : Yellow
- Panel matrix : 128*64
- Driver IC : SSD1303
- Excellent Quick response time : 10 μ s
- Extremely thin thickness for best mechanism design : 2.01 mm
- High contrast : 2000:1
- Wide viewing angle : 160°
- 8-bit 6800-series Parallel Interface, 8-bit 8080-series Parallel Interface, Serial Parallel Interface, I²C Interface.
- Strong environmental resistance
- Wide range of operating temperature : -40 to 85°C
- Anti-glare polarizer.

4. MECHANICAL DATA

NO	ITEM	SPECIFICATION	UNIT
1	Dot Matrix	128 (W) x 64 (H)	dot
2	Dot Size	0.4 (W) x 0.4 (H)	mm ²
3	Dot Pitch	0.43 (W) x 0.43 (H)	mm ²
4	Aperture Rate	86	%
5	Active Area	55.01 (W) x 27.49 (H)	mm ²
6	Panel Size	60.5 (W) x 37 (H)	mm ²
7	Panel Thickness	2.01 ± 0.1	mm
8	Module Size	60.5 (W) x 56.6 (H) x 2.01 (D)	mm ³
9	Diagonal A/A size	2.4	inch
10	Module Weight	9.59 ± 10%	gram

CONFIDENTIAL

5. MAXIMUM RATINGS

ITEM	MIN	MAX	UNIT	Condition	Remark
Supply Voltage (V _{DD})	-0.3	+3.5	V	Ta = 25 °C	IC maximum rating
Supply Voltage (V _{CC})	8	16	V	Ta = 25 °C	IC maximum rating
Operating Temp.	-40	85	°C		
Storage Temp	-40	85	°C		
Humidity		85	%		
Life Time	40,000	-	Hrs	100 cd/m ² , 50% checkerboard	Note (1)
Life Time	50,000	-	Hrs	80 cd/m ² , 50% checkerboard	Note (2)
Life Time	66,000	-	Hrs	60 cd/m ² , 50% checkerboard	Note (3)

Note:

(A) Under VCC = 13V, Ta = 25°C, 50% RH.

(B) Life time is defined the amount of time when the luminance has decayed to less than 50% of the initial measured luminance.

(1) Setting of 100 cd/m² :

- Contrast setting : 0XC5
- Frame rate : 105Hz
- Duty setting : 1/64

(2) Setting of 80 cd/m² :

- Contrast setting : 0x8F
- Frame rate : 105Hz
- Duty setting : 1/64

(3) Setting of 60 cd/m² :

- Contrast setting : 0x4C
- Frame rate : 105Hz
- Duty setting : 1/64

CONFIDENTIAL

6. ELECTRICAL CHARACTERISTICS

6.1 D.C ELECTRICAL CHARACTERISTICS

SYMBOL	PARAMETERS	TEST CONDITION	MIN	TYP	MAX	UNIT
V_{CC}	Analog power supply (for OLED panel)	$T_a = -20\text{ }^{\circ}\text{C}$ to $+70\text{ }^{\circ}\text{C}$	12.5	13	13.5	V
V_{DD}	Digital power supply	$T_a = -20\text{ }^{\circ}\text{C}$ to $+70\text{ }^{\circ}\text{C}$	2.4	2.7	3.5	V
I_{DD}	Operating current for V_{DD} V_{DD} 2.7V, V_{CC} 12V, I_{REF} 10uA No loading, All Display ON	Contrast=FF	-	190	300	uA
I_{CC}	Operating current for V_{CC} V_{DD} 2.7V, V_{CC} 12V, I_{REF} 10uA All Display ON	Contrast=FF	-	550	1000	uA
V_{IH}	High logic input level		0.8* V_{DD}	-	V_{DD}	V
V_{IL}	Low logic input level		0	-	0.2* V_{DD}	V
V_{OH}	High logic output level		0.9* V_{DD}	-	V_{DD}	V
V_{OL}	Low logic output level		0	-	0.1* V_{DD}	V
I_{SEG}	Segment on output current V_{DD} 2.7V, V_{CC} 12V, I_{REF} 10uA, Display on, Segment pin under test is connected with a 20K resistive load to V_{SS}	Contrast=FF	285	320	355	uA
		Contrast=AF	-	220	-	uA
		Contrast=5F	-	120	-	uA
		Contrast=0F	-	20	-	uA

Note 1: $V_{DD} = 2.7V$; $V_{CC} = 13V$; Frame rate= 105Hz ; No panel attached.

Note 2: The V_{CC} input must keep in a stable value; ripple and noise are not allowed.

CONFIDENTIAL

6.2 ELECTRO-OPTICAL CHARACTERISTICS

PANEL ELECTRICAL SPECIFICATIONS

PARAMETER	MIN	TYP.	MAX	UNITS	COMMENTS
Normal mode current		22	25	mA	All pixels on (1)
Standby mode current		2	3	mA	Standby mode 10% pixels on (2)
Normal mode power consumption		286	325	mW	All pixels on (1)
Standby mode power consumption		26	39	mW	Standby mode 10% pixels on (2)
Normal mode Luminance	60	80		cd/m ²	Display Average
Standby mode Luminance		30		cd/m ²	
CIE _x (Yellow)	0.43	0.47	0.51		x, y (CIE 1931)
CIE _y (Yellow)	0.45	0.49	0.53		
Dark Room Contrast	2000:1				
Viewing Angle	160			degree	
Response Time		10		μs	

(1) Normal mode condition :

- Driving Voltage : 13V
- Contrast setting : 0x8F
- Frame rate : 105Hz
- Duty setting : 1/64

(2) Standby mode condition :

- Driving Voltage : 13V
- Contrast setting : 0x00
- Frame rate : 105Hz
- Duty setting : 1/64

CONFIDENTIAL

7. INTERFACE

7.1 FUNCTION BLOCK DIAGRAM

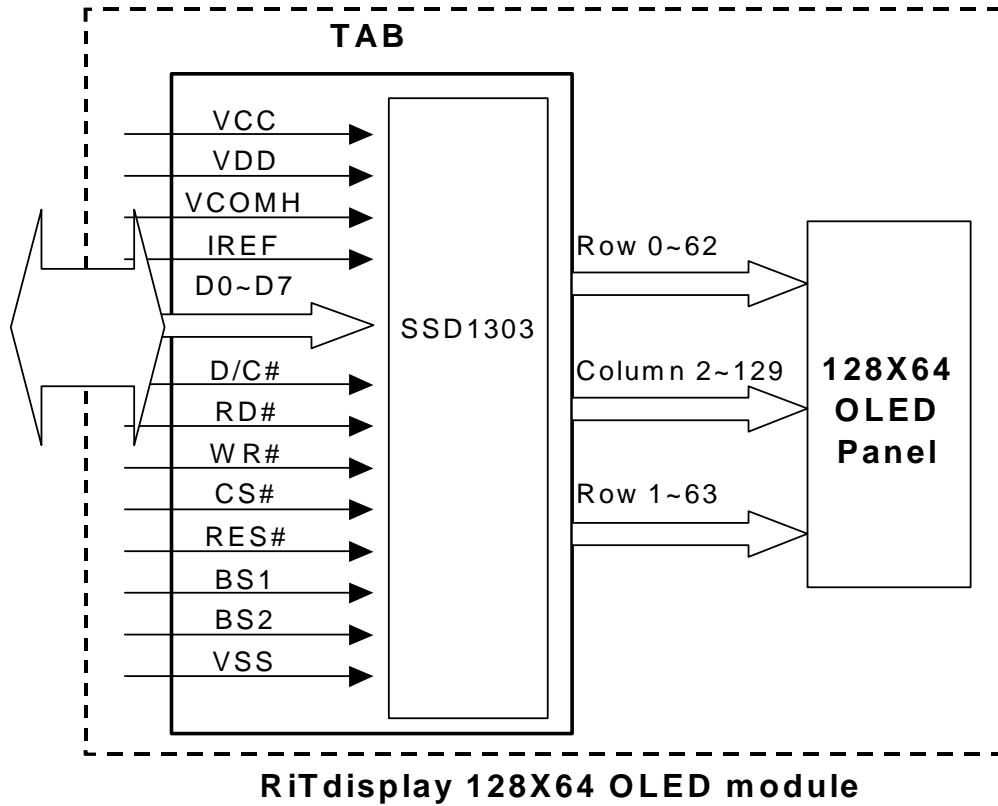

CONFIDENTIAL

7.2 PANEL LAYOUT DIAGRAM

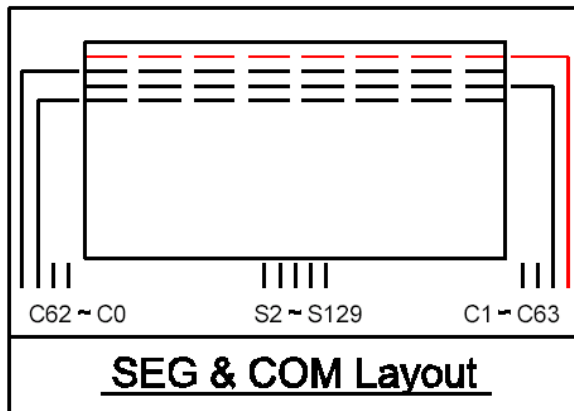

7.3 PIN ASSIGNMENTS

Pin No.	Pin Name	TYPE	Description
1	NC	-	No connection
2	VSS	I	This is a ground pin.
3	TEST0	-	Reserved pin; No connection and left float.
4	TEST1	-	
5	TEST2	-	
6	TEST3	-	
7	TEST4	-	
8	NC	-	No connection
9	NC	-	
10	NC	-	
11	VDD	I	Voltage Power supply for logic.
12	BS1	I	MCU interface selection input.
13	BS2	I	
14	NC	-	No connection
15	CS	I	This is Chip select Control pin.
16	RES	I	Hardware reset pin.
17	D/C	I	This is Data/Command Control pin. H:Data Input · L:Command Input.
18	WR	I	Data write operation is initiated when it's pull low
19	RD	I	Data read operation is initiated when it's pull low
20	D0	I/O	8 bits MPU data bus I/O
21	D1	I/O	
22	D2	I/O	
23	D3	I/O	
24	D4	I/O	
25	D5	I/O	
26	D6	I/O	
27	D7	I/O	
28	IREF	I	The Current reference input pin, a resistor should be connected between this pin and V _{ss} .
29	VCOMH	I	The Com voltage reference input pin, a capacitor should be connected between this pin and V _{ss} .
30	VCC	I	Analog power supply input.
31	NC	-	No connection

CONFIDENTIAL

7.4 GRAPHIC DISPLAY DATA RAM ADDRESS MAP

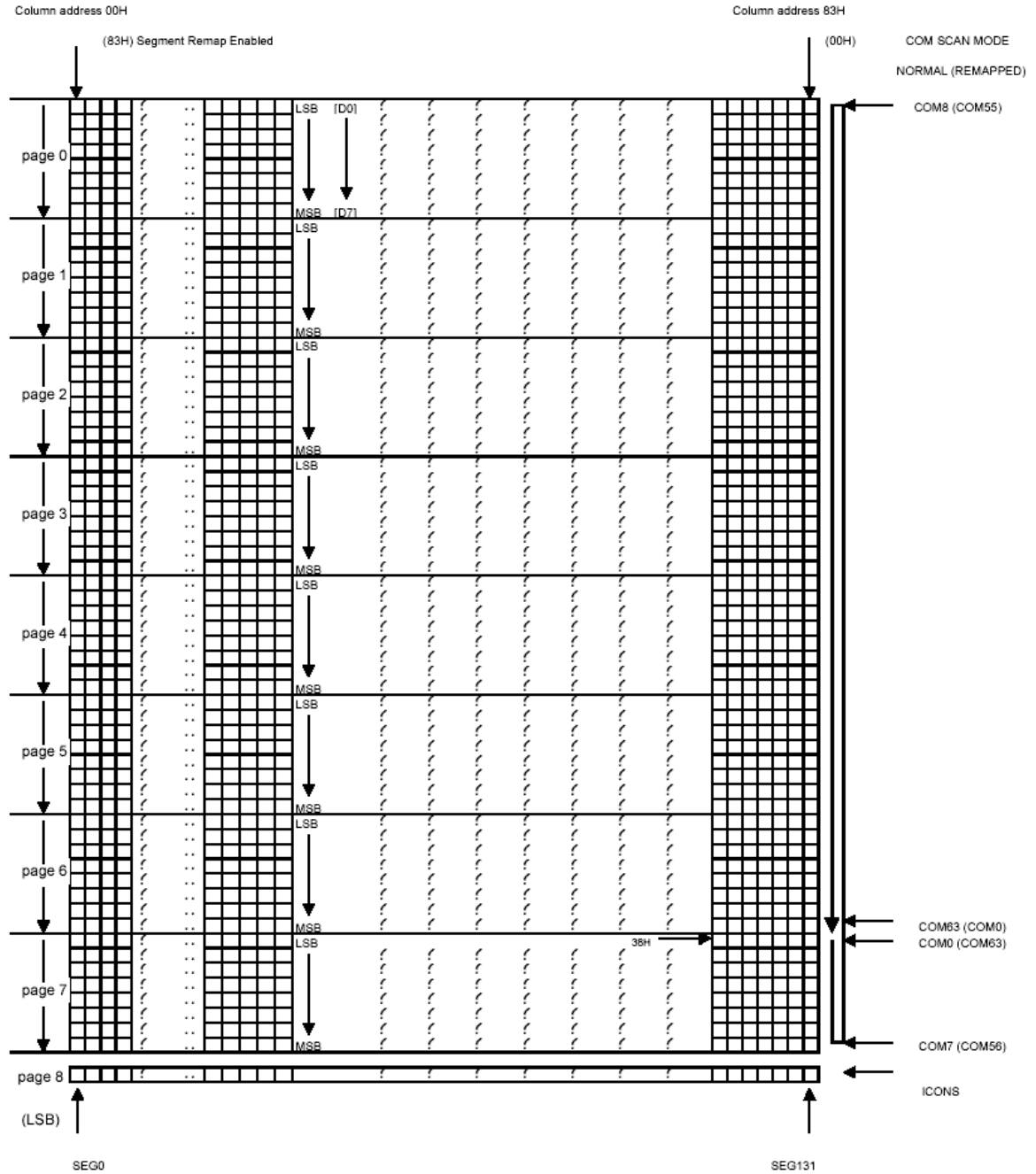

CONFIDENTIAL

7.5 INTERFACE TIMING CHART

8080-Series MCU Parallel Interface Timing Characteristics

Symbol	Parameter	Min	Typ	Max	Unit
t_{cycle}	Clock Cycle Time	300	-	-	ns
t_{AS}	Address Setup Time	0	-	-	ns
t_{AH}	Address Hold Time	0	-	-	ns
t_{DSW}	Write Data Setup Time	40	-	-	ns
t_{DHW}	Write Data Hold Time	15	-	-	ns
t_{DHR}	Read Data Hold Time	20	-	-	ns
t_{OH}	Output Disable Time	-	-	70	ns
t_{ACC}	Access Time	-	-	140	ns
PW_{CSL}	Chip Select Low Pulse Width (read) Chip Select Low Pulse Width (write)	120 60	-	-	ns
PW_{CSH}	Chip Select High Pulse Width (read) Chip Select High Pulse Width (write)	60 60	-	-	ns
t_R	Rise Time	-	-	15	ns
t_F	Fall Time	-	-	15	ns

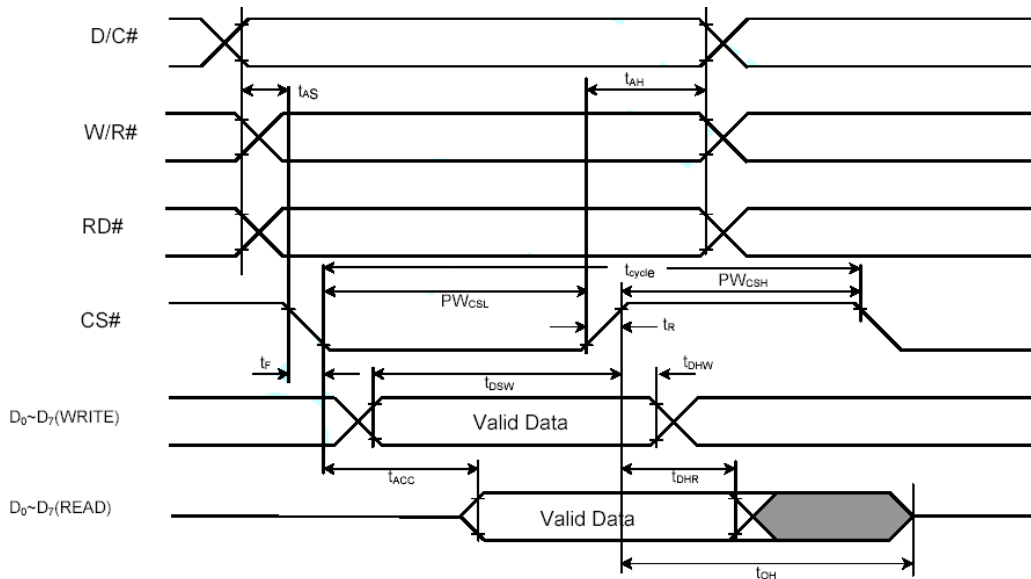

CONFIDENTIAL

8. APPLICATION CIRCUIT

8.1 APPLICATION CIRCUIT

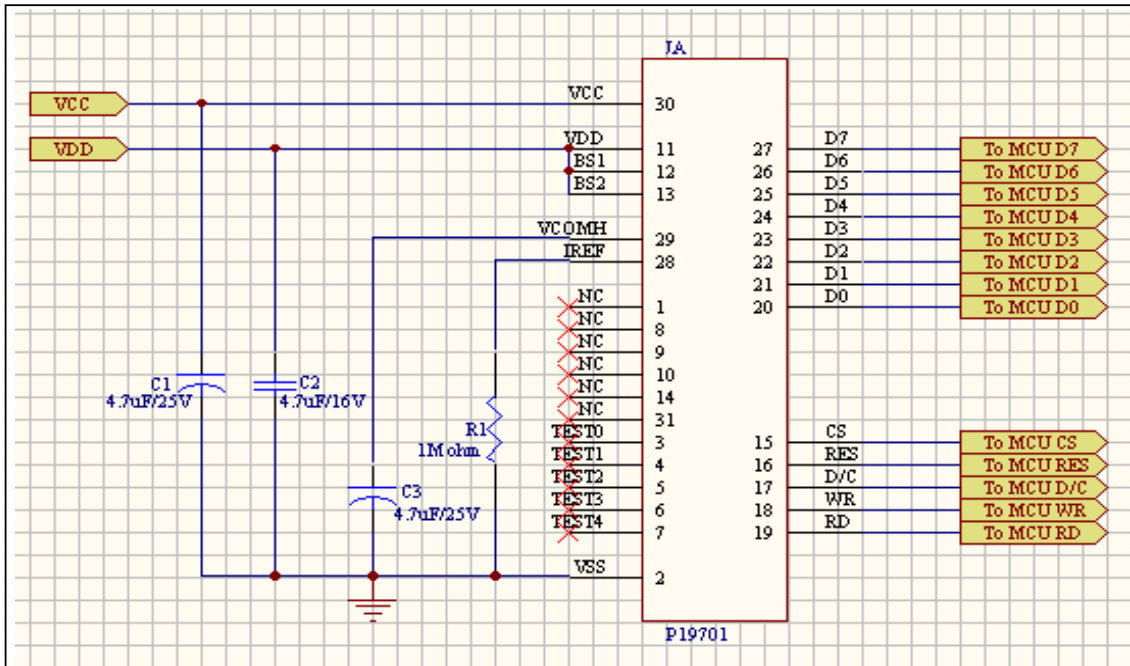

Recommended components

R1 : 1M ohm (0603),1%.

C1 : 4.7uF (Tantalum Type) / 25V, C2 : 4.7uF (0805) / 16V ,

C3 : 4.7uF (Tantalum Type) / 25V.

This circuit is designed for 8080 8-bits interface.

CONFIDENTIAL

External DC-DC application circuit

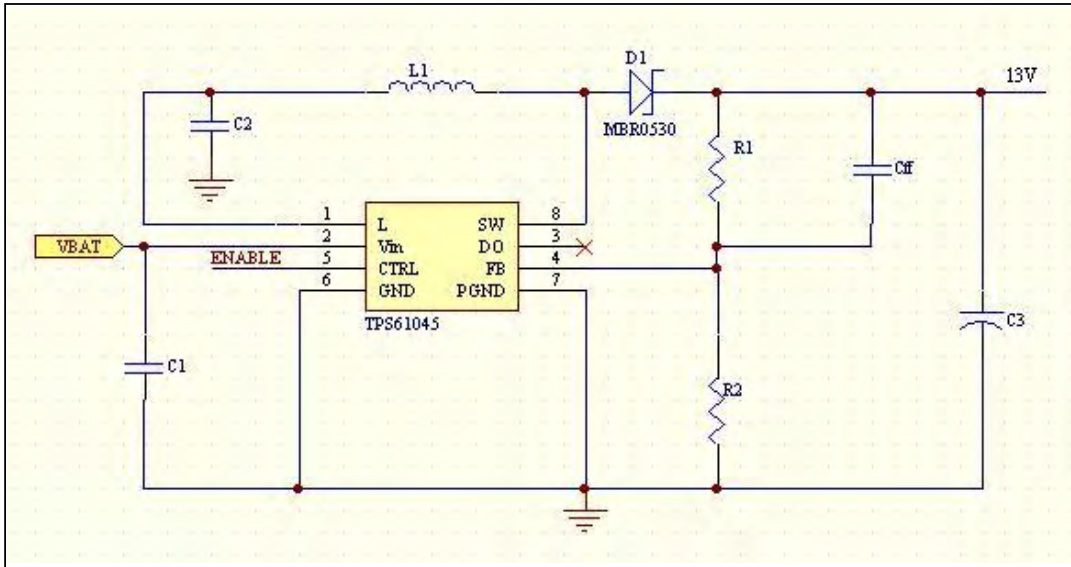

Recommended components

C1: 0.1uF(0603) / 25V, C2 : 4.7uF (Tantalum Type) / 25V,

C3 : 4.7uF (Tantalum Type) / 25V.

Cff : 22pF(0603) / 16V.

D1:Schottky Diode.

L1: 10uH.

R1: 1.2M ohm (0603), 1%, R2: 127K ohm (0603), 1%.

VBAT = 1.8V ~ 6.0V(The Detail Application,please refer the IC data sheet).

8.2 COMMAND TABLE

Refer to IC Spec.: SSD1303

CONFIDENTIAL

9. RELIABILITY TEST CONDITIONS

No.	Items	Specification	Quantity
1	High temp. (Non-operation)	85°C, 240hrs	5
2	High temp. (Operation)	85°C, 120hrs	5
3	Low temp. (Operation)	-40°C, 120hrs	5
4	High temp. / High humidity (Operation)	65°C, 90%RH, 120hrs	5
5	Thermal shock (Non-operation)	-40°C ~85°C (-40°C /30min; transit /3min; 85°C /30min; transit /3min) 1cycle: 66min, 100 cycles	5
6	Vibration	Frequency : 5~50HZ, 0.5G Scan rate : 1 oct/min Time : 2 hrs/axis Test axis : X, Y, Z	1 Carton
7	Drop	Height: 120cm Sequence : 1 angle 、 3 edges and 6 faces Cycles: 1	1 Carton
8	ESD (Non-operation)	Air discharge model, ±8kV, 10 times	5

Test and measurement conditions

1. All measurements shall not be started until the specimens attain to temperature stability.
2. All-pixels-on is used as operation test pattern.
3. The degradation of Polarizer are ignored for item 1, 2, 4 & 5.

Evaluation criteria

1. The function test is OK.
2. No observable defects.
3. Luminance: > 50% of initial value.
4. Current consumption: within $\pm 50\%$ of initial value.

CONFIDENTIAL

10. EXTERNAL DIMENSION

CONFIDENTIAL

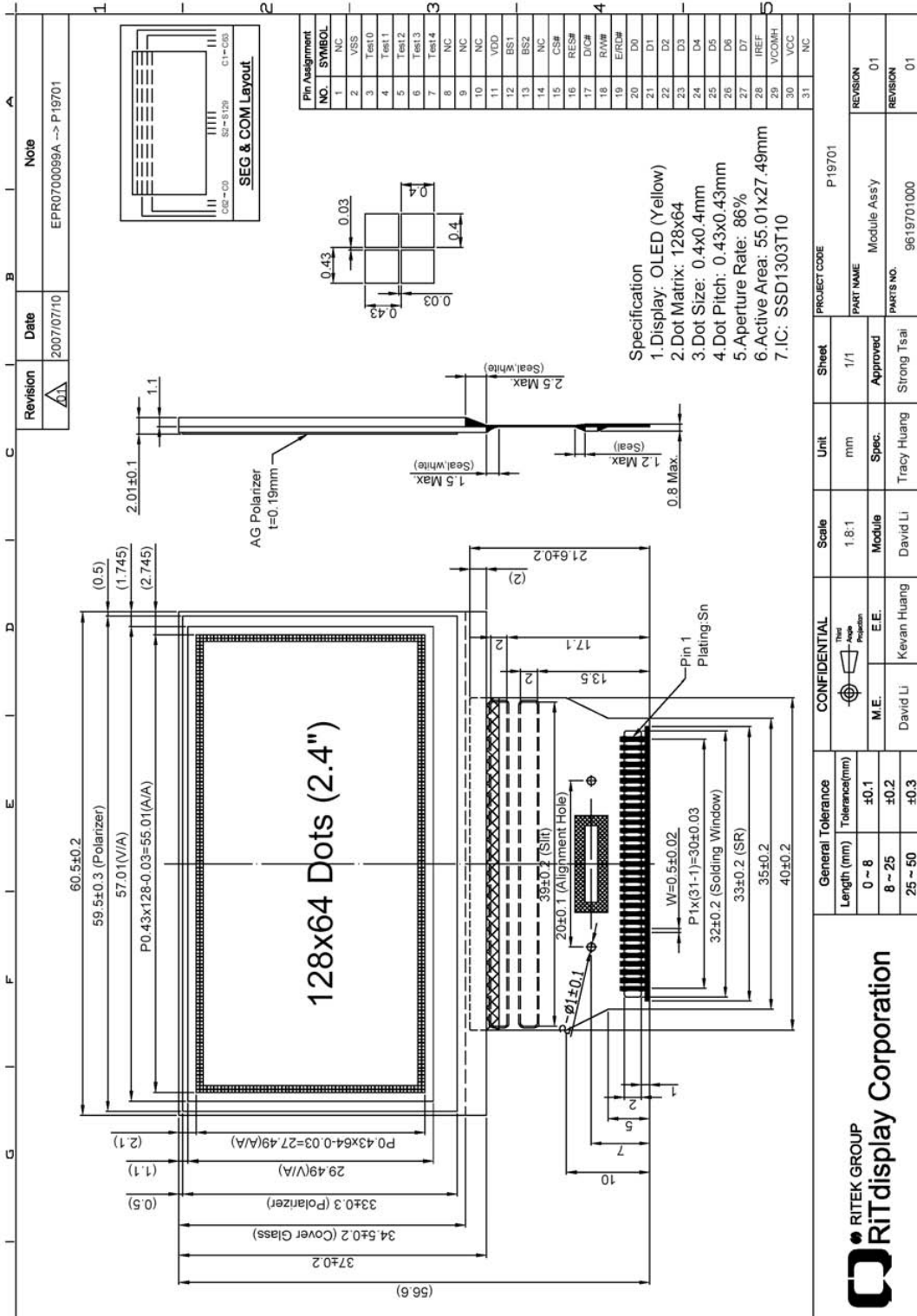

11. PACKING SPECIFICATION

	Revision	Date	Note
A	01	2007/09/12	Packing Tray Instruction

Item	Part No.	Description	QTY
1	9619701000	P19701 Module Assy	480
2	300800106	Tray 330x270x8.7mm, t=0.7mm	32
3	301000002	5G 封装芯片	8
4	300300012	真空包装袋 480x285x80mm	2
5	300300016	Antistatic Bubble Bag 440x(350+450)mm	2
6	300100005	Pizza Box 345x285x88, B浪	2
7	300800009	黄色纸箱, 385x305x203mm	1
8	300800000	Label	3
9	320800125	封箱胶带	

General Tolerance		CONFIDENTIAL		Scale	Unit	Sheet	PROJECT CODE
Length (mm)	Tolerance(mm)	M.E.	The App. Program	1:9	mm	1/1	P19701
0 ~ 8	±0.1	David Li	E.E.	Module	Spec.	Approved	PART NAME
8 ~ 25	±0.2	Kevan Huang	M.E.	David Li	Tracy Huang	Strong Tsa	Packing Tray Instruction
25 ~ 50	±0.3	David Li	M.E.	Kevan Huang	Tracy Huang	Strong Tsa	PART NO.
							9919701000
							REVISION
							REVISION
							REVISION

12. APPENDIXES

APPENDIX 1: DEFINITIONS

A. DEFINITION OF CHROMATICITY COORDINATE

The chromaticity coordinate is defined as the coordinate value on the CIE 1931 color chart for R, G, B, W.

B. DEFINITION OF CONTRAST RATIO

The contrast ratio is defined as the following formula:

$$\text{Contrast Ratio} = \frac{\text{Luminance of all pixels on measurement}}{\text{Luminance of all pixels off measurement}}$$

C. DEFINITION OF RESPONSE TIME

The definition of turn-on response time T_r is the time interval between a pixel reaching 10% of steady state luminance and 90% of steady state luminance. The definition of turn-off response time T_f is the time interval between a pixel reaching 90% of steady state luminance and 10% of steady state luminance. It is shown in Figure 2.

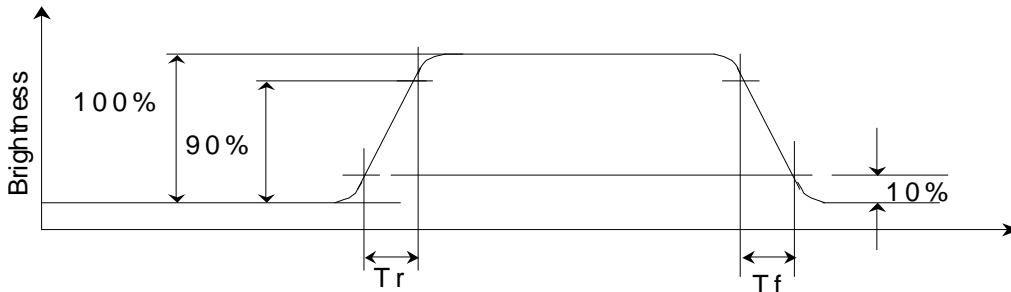

Figure 2 Response time

CONFIDENTIAL

D. DEFINITION OF VIEWING ANGLE

The viewing angle is defined as Figure 3. Horizontal and vertical (H & V) angles are determined for viewing directions where luminance varies by 50% of the perpendicular value.

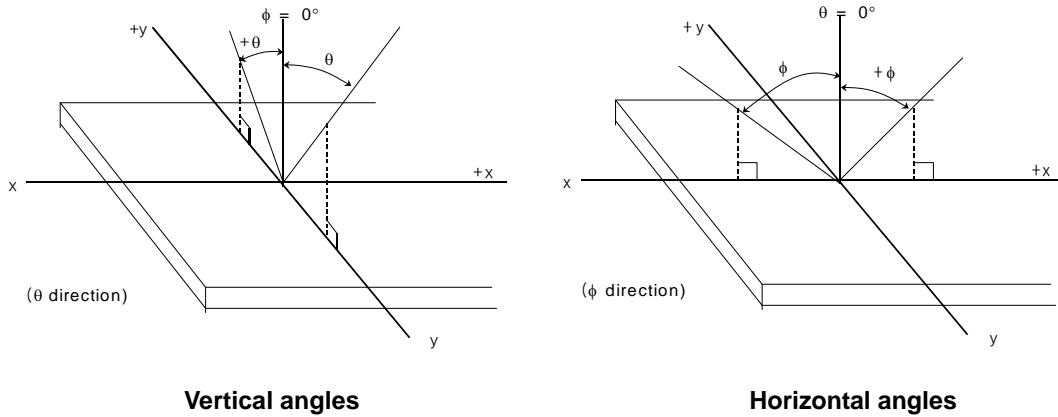

Figure 3 Viewing Angle

CONFIDENTIAL

APPENDIX 2: MEASUREMENT APPARATUS

A. LUMINANCE/COLOR COORDINATE

PHOTO RESEARCH PR-705, MINOLTA CS-100

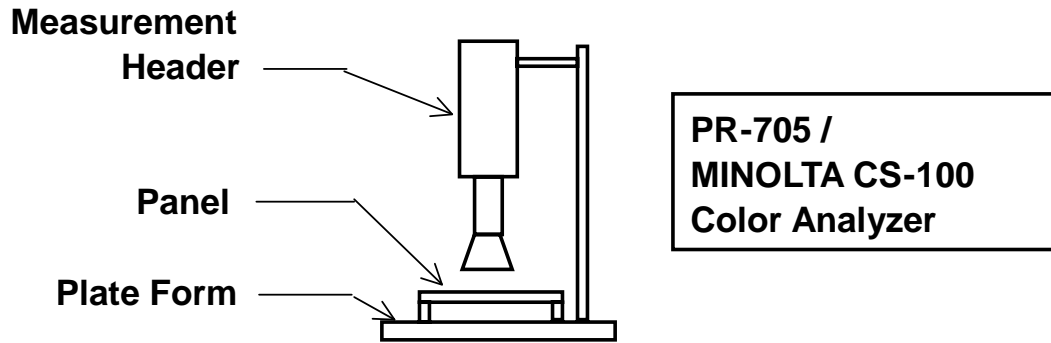

B. CONTRAST / RESPONSE TIME / VIEWING ANGLE

WESTAR CORPORATION FPM-510

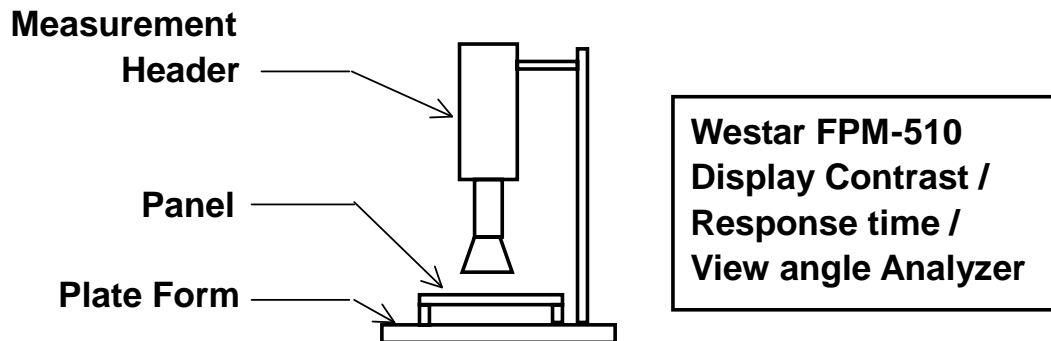

CONFIDENTIAL

C. ESD ON AIR DISCHARGE MODE

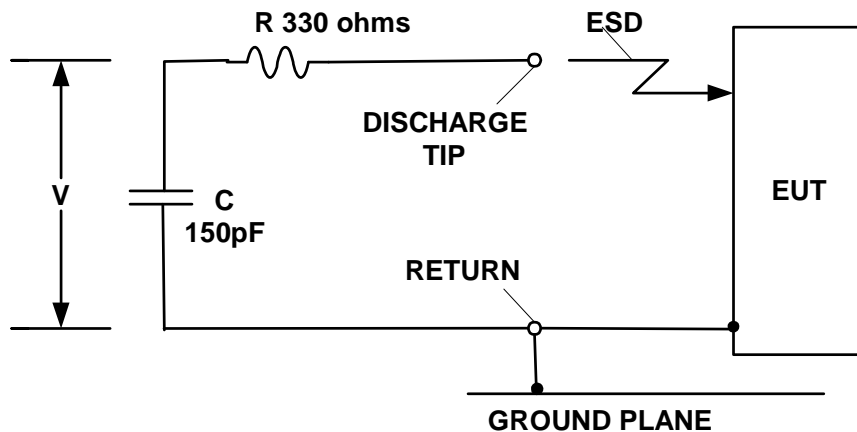

CONFIDENTIAL

APPENDIX 3: PRECAUTIONS

A. RESIDUE IMAGE

Because the pixels are lighted in different time, the luminance of active pixels may reduce or differ from inactive pixels. Therefore, the residue image will occur. To avoid the residue image, every pixel needs to be lighted up uniformly.

CONFIDENTIAL



Displays

US Micro Products is an industrial distributor specializing in engineered display solutions. We dedicate ourselves to providing the best in displays for the medical, industrial, gaming, automotive, aerospace, military and consumer markets.

OLEDs



TFT Display



Open Frame Monitors



Passive LCDs



Multitouch



Touch Screen



As our customer, you receive expert knowledge, support and service. Our technical sales staff and experienced design engineers provide answers to your questions and engineered solutions to meet your display needs.

Peripheral Devices

Our full line of peripheral devices includes keyboards, trackballs and printers. These rugged industrial products are designed to meet the rigorous demands of your equipment and are available in a variety of standard and custom options.

Keyboards



Trackballs



Aerospace Trackballs



Printers

