



**US Micro Products**  
*Electronic Products for the OEM*

# TFT-LCD PRODUCT SPECIFICATION

Manufactured by



<b>PART NUMBER:</b>	<b>USMP-M150XN07 V9</b>
<b>DESCRIPTION:</b>	15" TFT LCD with XGA+ (1024(H) x 768(V)) screen format and 16.2M colors.

ISSUE DATE	APPROVED BY (Customer Use Only)	CHECKED BY	PREPARED BY
<b>PROPRIETARY NOTE:</b>	THIS SPECIFICATION IS THE PROPERTY OF US MICRO PRODUCTS AND SHALL NOT BE REPRODUCED OR COPIED WITHOUT THE WRITTEN PERMISSION OF US MICRO PRODUCTS AND MUST BE RETURNED TO US MICRO PRODUCTS UPON ITS REQUEST.		



## Contents

<b>1. Handling Precautions .....</b>	<b>4</b>
<b>2. General Description.....</b>	<b>5</b>
2.1 Display Characteristics .....	5
<b>3. Functional Block Diagram.....</b>	<b>10</b>
<b>4. Absolute Maximum Ratings .....</b>	<b>11</b>
4.1 Absolute Ratings of TFT LCD Module.....	11
4.2 Absolute Ratings of Backlight Unit.....	11
4.3 Absolute Ratings of Environment .....	12
<b>5. Electrical characteristics.....</b>	<b>13</b>
5.1 TFT LCD Module.....	13
5.2 Backlight Unit.....	15
<b>6. Signal Characteristic .....</b>	<b>16</b>
6.1 Pixel Format Image .....	16
6.2 The Input Data Format.....	17
6.4 Interface Timing.....	20
6.5 Power ON/OFF Sequence .....	23
<b>7. Connector &amp; Pin Assignment .....</b>	<b>24</b>
7.1 TFT LCD Module.....	24
7.2 Backlight Unit.....	25
<b>8. Reliability Test .....</b>	<b>26</b>
<b>9. Shipping Label .....</b>	<b>27</b>
<b>10. Mechanical Characteristics.....</b>	<b>28</b>

CONFIDENTIAL



**Record of Revision**

Version and Date	Page	Old description	New Description	Remark
0.1 2006/09/05	All	First Edition for Customer	All	

CONFIDENTIAL



## 1. Handling Precautions

- 1) Since front polarizer is easily damaged, pay attention not to scratch it.
- 2) Be sure to turn off power supply when inserting or disconnecting from input connector.
- 3) Wipe off water drop immediately. Long contact with water may cause discoloration or spots.
- 4) When the panel surface is soiled, wipe it with absorbent cotton or other soft cloth.
- 5) Since the panel is made of glass, it may break or crack if dropped or bumped on hard surface.
- 6) Since CMOS LSI is used in this module, take care of static electricity and insure human earth when handling.
- 7) Do not open or modify the Module Assembly.
- 8) Do not press the reflector sheet at the back of the module to any directions.
- 9) In case if a Module has to be put back into the packing container slot after once it was taken out from the container, do not press the center of the CCFL reflector edge. Instead, press at the far ends of the CCFL Reflector edge softly. Otherwise the TFT Module may be damaged.
- 10) At the insertion or removal of the Signal Interface Connector, be sure not to rotate nor tilt the Interface Connector of the TFT Module.
- 11) After installation of the TFT Module into an enclosure, do not twist nor bend the TFT Module even momentary. At designing the enclosure, it should be taken into consideration that no bending/twisting forces are applied to the TFT Module from outside. Otherwise the TFT Module may be damaged.
- 12) Cold cathode fluorescent lamp in LCD contains a small amount of mercury. Please follow local ordinances or regulations for disposal.
- 13) Small amount of materials having no flammability grade is used in the LCD module. The LCD module should be supplied by power complied with requirements of Limited Power Source (IEC60950 or UL1950), or be applied exemption.
- 14) The LCD module is designed so that the CCFL in it is supplied by Limited Current Circuit (IEC60950 or UL1950). Do not connect the CCFL in Hazardous Voltage Circuit.

CONFIDENTIAL



## 2. General Description

This specification applies to the 15 inch Color TFT-LCD Module M150XN07 v9.

The display supports the XGA+ (1024(H) x 768(V)) screen format and 16.2M colors. All input signals are 1 Channel LVDS interface compatible.

This module does not contain an inverter card for backlight.

### 2.1 Display Characteristics

The following items are characteristics summary on the table under 25 °C condition:

Items	Unit	Specifications
Active Area	[mm]	304.128 (H) x 228.096
Pixels H x V		1024(x3) x 768
Pixel Pitch	[mm]	0.297 (per one triad) x 0.297
Pixel Arrangement		R.G.B. Vertical Stripe
Display Mode		TN mode, Normally White
White Luminance	[cd/m <sup>2</sup> ]	250 (Typ) @ 8mA
Contrast Ratio		700
Optical ResponseTime	[msec]	8 (Typ, on/off)
Nominal Input Voltage VDD	[Volt]	+3.3 (Typ)
Power Consumption (VDD line + CCFL line)	[Watt]	12.5 W (Typ) (PDD=2.5 W, PCFL=10W @Lamp=8mA)
Weight	[Grams]	1010 (Typ)
Physical Size (H x V x D)	[mm]	326.5(W) x 253.5(H) x 12(D) (Typ)
Electrical Interface		one Channel LVDS
Surface Treatment		Anti-glare type, Hardness 3H
Support Colors		16.2M colors (RGB 6-bits+FRC)
RoHS Compliance		RoHS Compliance

CONFIDENTIAL



## 2.2 Optical Characteristics

The optical characteristics are measured under stable conditions at 25°C (Room Temperature):

Item	Unit	Conditions	Min.	Typ.	Max.	Note
Viewing Angle	[degree]	Horizontal (Right) CR = 10 (Left)	60 60	70 70	-	1
		Vertical (Up) CR = 10 (Down)	55 50	65 60	-	
Luminance Uniformity	[%]	9 Points	75	80	-	2, 3
Optical Response Time	[msec]	Rising	-	6	9	4, 6
		Falling	-	2	4	
		Rising + Falling	-	8	13	
Color / Chromaticity Coordinates (CIE 1931)		Red x	0.612	0.642	0.672	4
		Red y	0.307	0.337	0.367	
		Green x	0.276	0.306	0.336	
		Green y	0.551	0.581	0.611	
		Blue x	0.114	0.144	0.174	
		Blue y	0.071	0.101	0.131	
		White x	0.283	0.313	0.343	
White y	0.299	0.329	0.359			
White Luminance (At CCFL= 6.5mA)	[cd/m <sup>2</sup> ]		200	250	-	4
Contrast Ratio			450	700	-	4
Cross Talk (At 75Hz)	[%]		-	1.2	1.5	5
Flicker	[dB]		-		-20	7

Optical Equipment: BM-5A, BM-7, PR880, or equivalent

CONFIDENTIAL

Note 1: Definition of viewing angle

Viewing angle is the measurement of contrast ratio  $\geq 10$ , at the screen center, over a 180° horizontal and 180° vertical range (off-normal viewing angles). The 180° viewing angle range is broken down as follows; 90° ( $\theta$ ) horizontal left and right and 90° ( $\Phi$ ) vertical, high (up) and low (down). The measurement direction is typically perpendicular to the display surface with the screen rotated about its center to develop the desired measurement viewing angle.

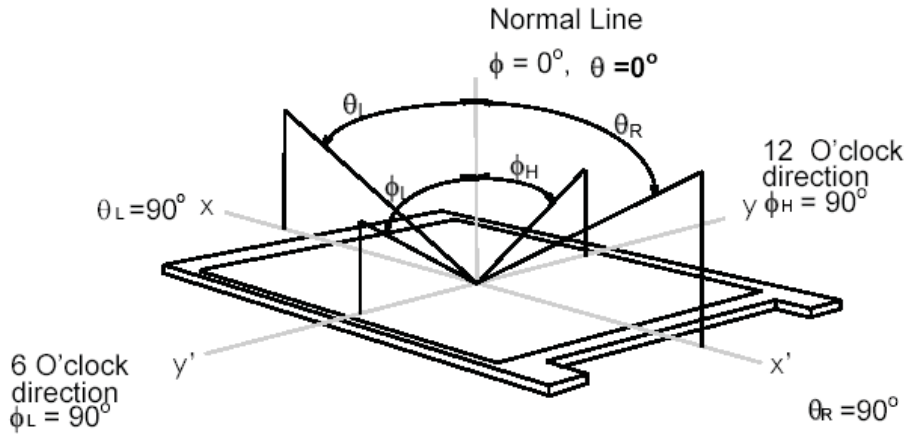

Note 2: 9 points position

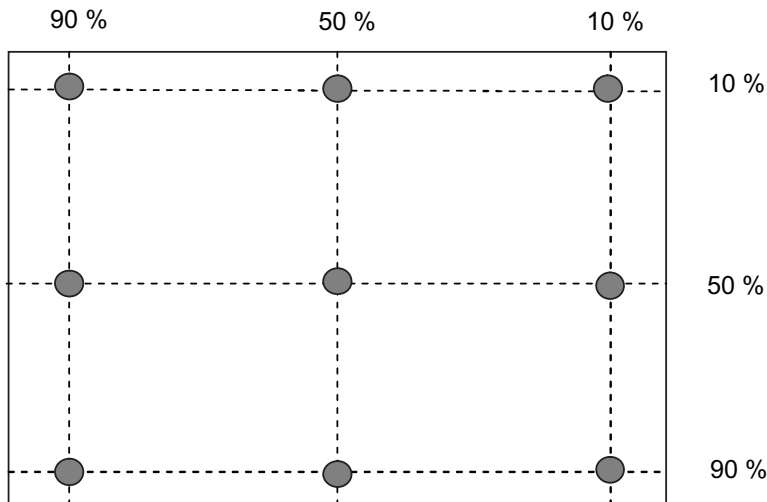

Note 3: The luminance uniformity of 9 points is defined by dividing the maximum luminance values by the minimum test point luminance

$$\delta_{w9} = \frac{\text{Minimum Luminance of 9 points}}{\text{Maximum Luminance of 9 points}}$$

CONFIDENTIAL

Note 4: Measurement method

The LCD module should be stabilized at given temperature for 30 minutes to avoid abrupt temperature change during measuring. In order to stabilize the luminance, the measurement should be executed after lighting Backlight for 30 minutes in a stable, windless and dark room.

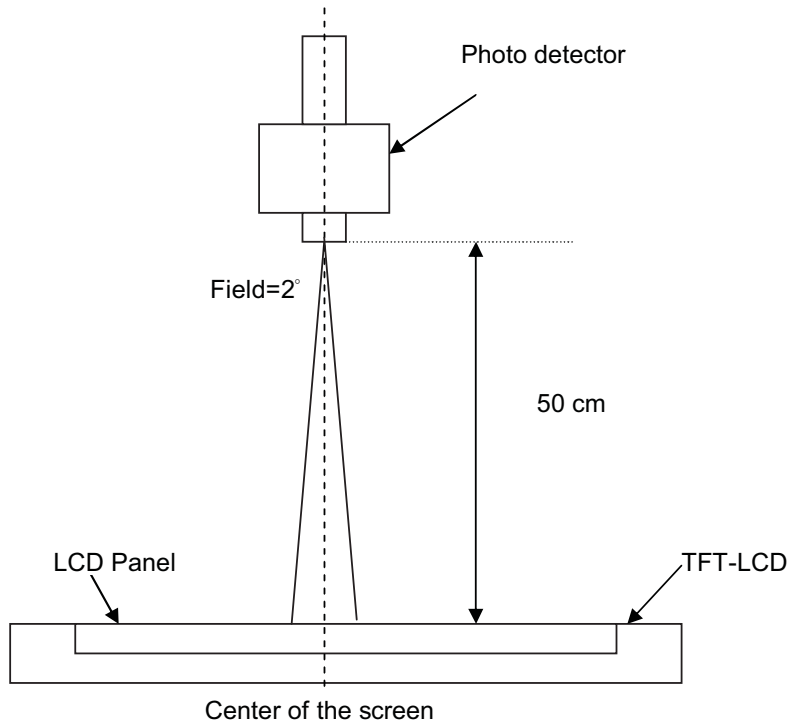

CONFIDENTIAL

Note 5: Definition of Cross Talk (CT)

$$CT = |Y_B - Y_A| / Y_A \times 100 (\%)$$

Where

Y<sub>A</sub> = Luminance of measured location without gray level 0 pattern (cd/m<sup>2</sup>)

Y<sub>B</sub> = Luminance of measured location with gray level 0 pattern (cd/m<sup>2</sup>)

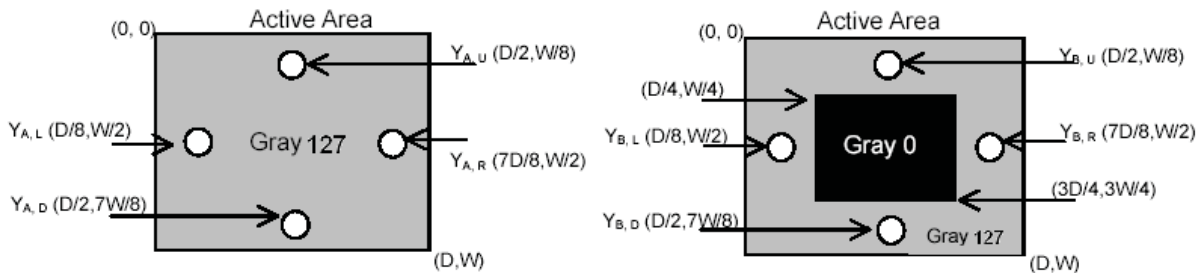



Note 6: Definition of response time:

The output signals of photo detector are measured when the input signals are changed from “Full Black” to “Full White” (rising time), and from “Full White” to “Full Black” (falling time), respectively. The response time is interval between the 10% and 90% of amplitudes. Please refer to the figure as below.

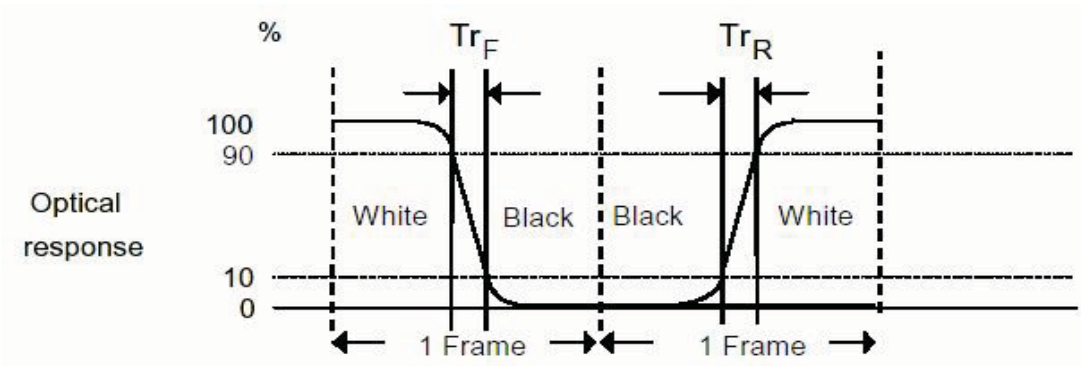

Note 7: Subchecker Pattern

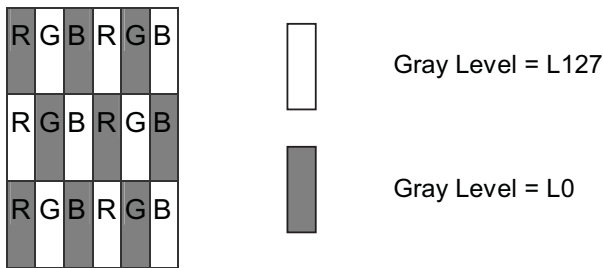

Method: Record dBV & DC value with (WESTAR)TRD-100

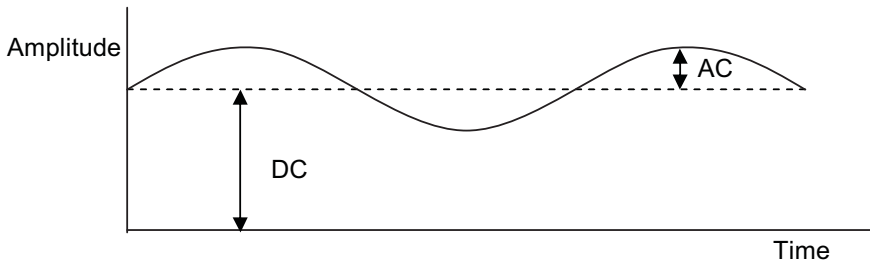

$$\text{Flicker (dB)} = 20 \log \frac{\text{AC Level(at 30 Hz)}}{\text{DC Level}}$$

CONFIDENTIAL

### 3. Functional Block Diagram

The following diagram shows the functional block of the 15.0 inches wide Color TFT-LCD Module:

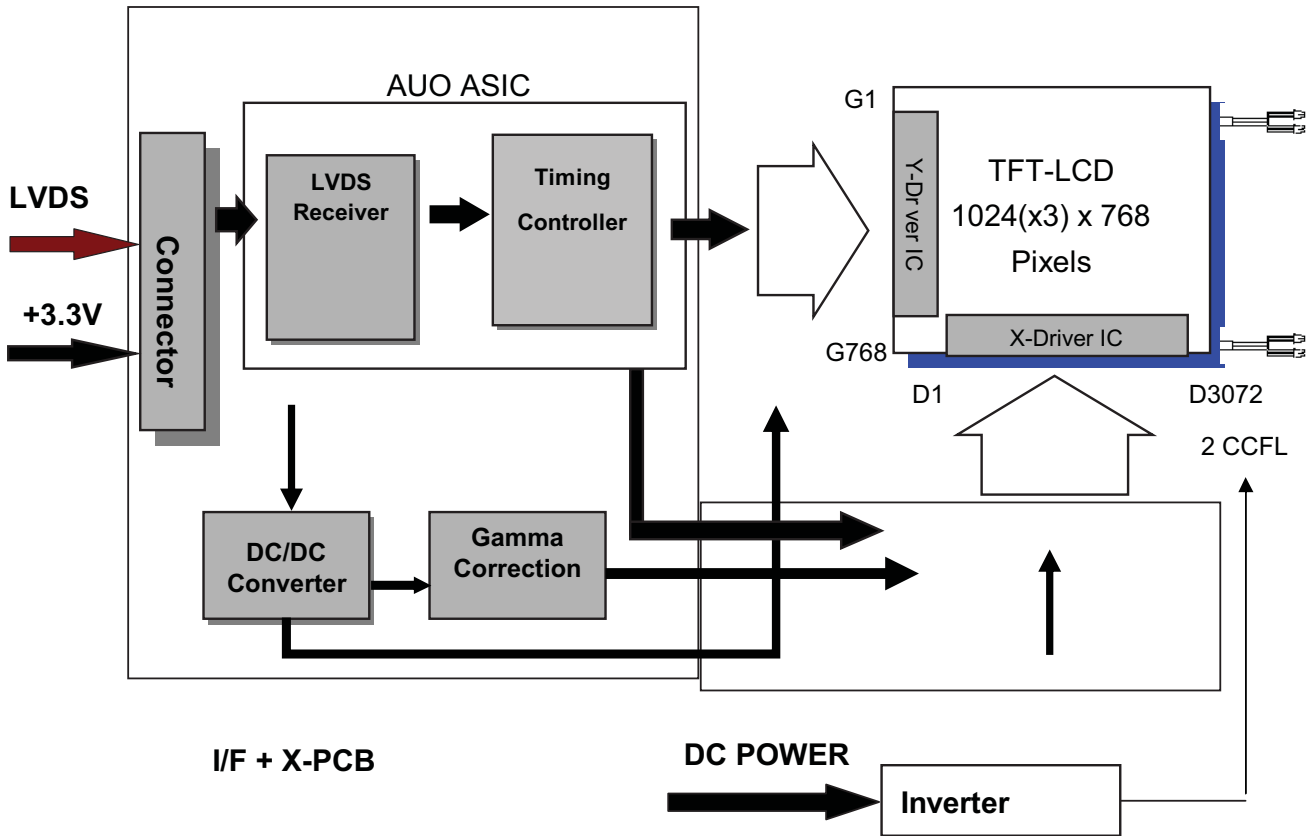

CONFIDENTIAL

Type Part Number                      **MSB240420E/ 3804-E20N-06R**                      **35001HS-02L**

Mating Housing Part Number    **HRS DF14-20S-1.25C**                      **35001WR-02L**



#### 4. Absolute Maximum Ratings

Absolute maximum ratings of the module is as following:

##### 4.1 Absolute Ratings of TFT LCD Module

Item	Symbol	Min.	Max.	Unit	Conditions
Logic/LCD Drive Voltage	VDD	0.3	+3.6	[Volt]	<i>Note 1,2</i>

##### 4.2 Absolute Ratings of Backlight Unit

Item	Symbol	Min.	Max.	Unit	Conditions
CCFL Current	ICFL	-	8.5	[mA] rms	<i>Note 1,2</i>

CONFIDENTIAL



### 4.3 Absolute Ratings of Environment



Item	Symbol	Min.	Max.	Unit	Conditions
Operating Temperature	TOP	0	+50	[°C]	Note 3
Operating Humidity	HOP	8	90	[%RH]	
Storage Temperature	TST	-20	+60	[°C]	
Storage Humidity	HST	8	90	[%RH]	

Note 1: With in  $T_a = 25^\circ\text{C}$

Note 2: Permanent damage to the device may occur if exceed maximum values

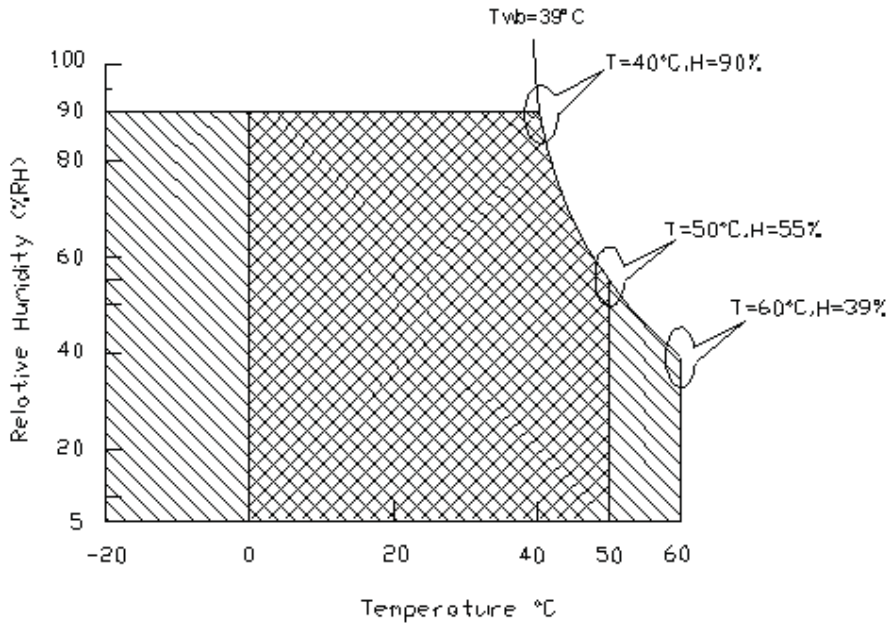
Note 3: For quality performance, please refer to AUO IIS (Incoming Inspection Standard).



Operating Range  Storage Range  + 

CONFIDENTIAL



## 5. Electrical characteristics

### 5.1 TFT LCD Module

#### 5.1.1 Power Specification

Input power specifications are as follows:

Symble	Parameter	Min.	Typ.	Max.	Unit	Condition
VDD	Logic/LCD Drive Voltage	3.0	3.3	3.6	[Volt]	± 10%
IDD	VDD current	-	750	850	[mA]	Vin=3.3V , Black Pattern, at 60Hz
Irush	LCD Inrush Current	-	-	3	[A]	<b>Note</b>
PDD	VDD Power		2.5	3	[Watt]	Vin=3.3V , Black Pattern, at 60Hz

**Note:** Measurement conditions:

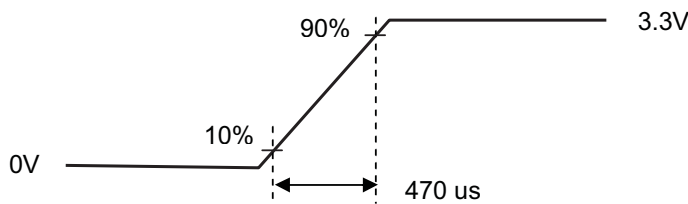
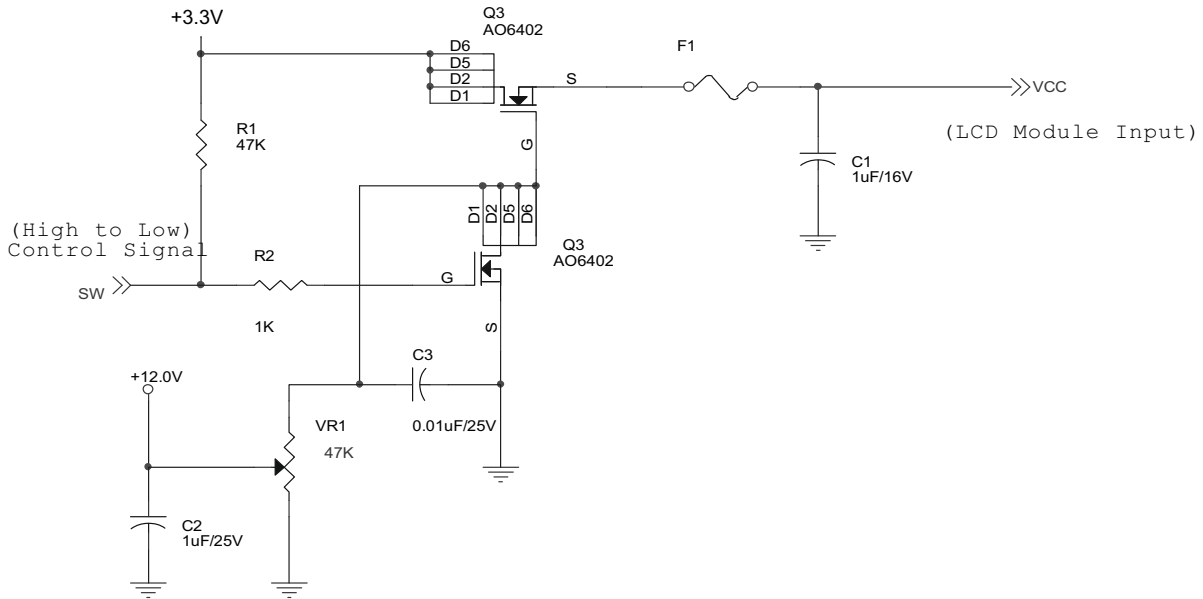

CONFIDENTIAL



### 5.1.2 Signal Electrical Characteristics

Input signals shall be low or Hi-Z state when Vin is off

It is recommended to refer the specifications of SN75LVDS82DGG (Texas Instruments) in detail.

Each signal characteristics are as follows;

Symbol	Parameter	Min	Typ	Max	Units	Condition	
VTH	Differential Input High Threshold	-	-	100	[mV]	VICM = 1.2V	<b>Note</b>
VTL	Differential Input Low Threshold	-100	-	-	[mV]	VICM = 1.2V	<b>Note</b>
VID	Input Differential Voltage	100	400	600	[mV]		<b>Note</b>
VICM	Differential Input Common Mode Voltage	1.0	1.2	1.5	[V]	VTH/VTL = ± 100mV	<b>Note</b>

**Note:** LVDS Signal Waveform

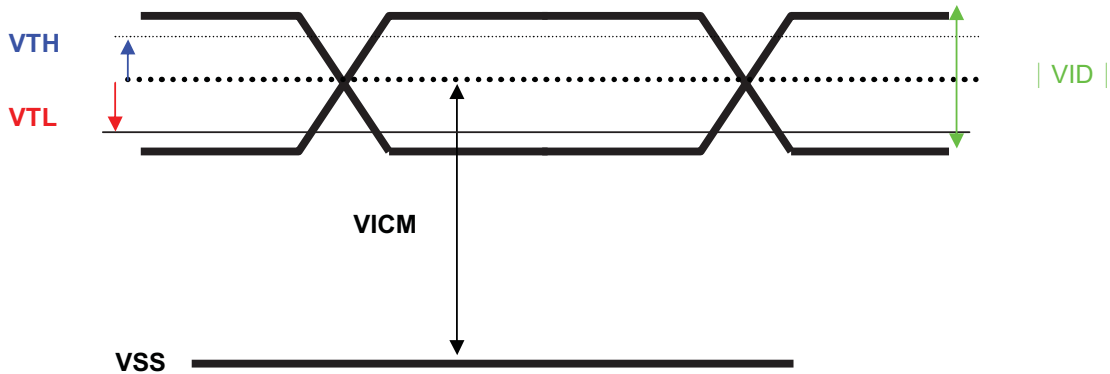

CONFIDENTIAL



## 5.2 Backlight Unit

Parameter guideline for CCFL Inverter is under stable conditions at 25°C (Room Temperature):

Parameter	Min.	Typ.	Max.	Unit	Condition
CCFL Standard Current(ISCFL)	7.5	8	8.5	[mA] rms	Note 2
CCFL Operation Current(IRCFL)	2.5	8	8.5	[mA] rms	Note 2
CCFL Frequency(FCFL)	40	55	80	[KHz]	Note 3,4
CCFL Ignition Voltage(ViCFL, Ta= 0°C)	1450	-	-	[Volt] rms	Note 5
CCFL Ignition Voltage(ViCF, Ta= 25°C)	1100	-	-	[Volt] rms	
CCFL Operation Voltage (VCFL)	-	620 (@ 8mA)	-	[Volt] rms	Note 6
CCFL Power Consumption(PCFL)	-	10	11	[Watt]	Note 6
CCFL Life Time(LTCFL)		30000	40000	[Hour]	Note 7

Note 1: Typ. are AUO recommended design points.

- \*1 All of characteristics listed are measured under the condition using the AUO test inverter.
- \*2 In case of using an inverter other than listed, it is recommended to check the inverter carefully. Sometimes, interfering noise stripes appear on the screen, and substandard luminance or flicker at low power may happen.
- \*3 In designing an inverter, it is suggested to check safety circuit very carefully. Impedance of CCFL, for instance, becomes more than 1 [M ohm] when CCFL is damaged.
- \*4 Generally, CCFL has some amount of delay time after applying kick-off voltage. It is recommended to keep on applying ignition voltage for 1 [Sec] until discharge.
- \*5 Reducing CCFL current increases CCFL discharge voltage and generally increases CCFL discharge frequency. So all the parameters of an inverter should be carefully designed so as not to produce too much leakage current from high-voltage output of the inverter.

Note 2: It should be employed the inverter which has "Duty Dimming", if IRCFL is less than 3mA.

Note 3: CCFL discharge frequency should be carefully determined to avoid interference between inverter and TFT LCD.

Note 4: The frequency range will not affect to lamp life and reliability characteristics.

Note 5: CCFL inverter should be able to give out a power that has a generating capacity of over 1,450 voltage. Lamp units need 1,450 voltage minimum for ignition.

Note 6: The variance of CCFL power consumption is ±10%. Calculator value for reference (ISCFL × VCFL × 2= PCFL)

Note 7: Definition of life: brightness becomes 50%. The typical life time of CCFL is under the condition at 8 mA lamp current.

CONFIDENTIAL



## 6. Signal Characteristic

### 6.1 Pixel Format Image

Following figure shows the relationship of the input signals and LCD pixel format.

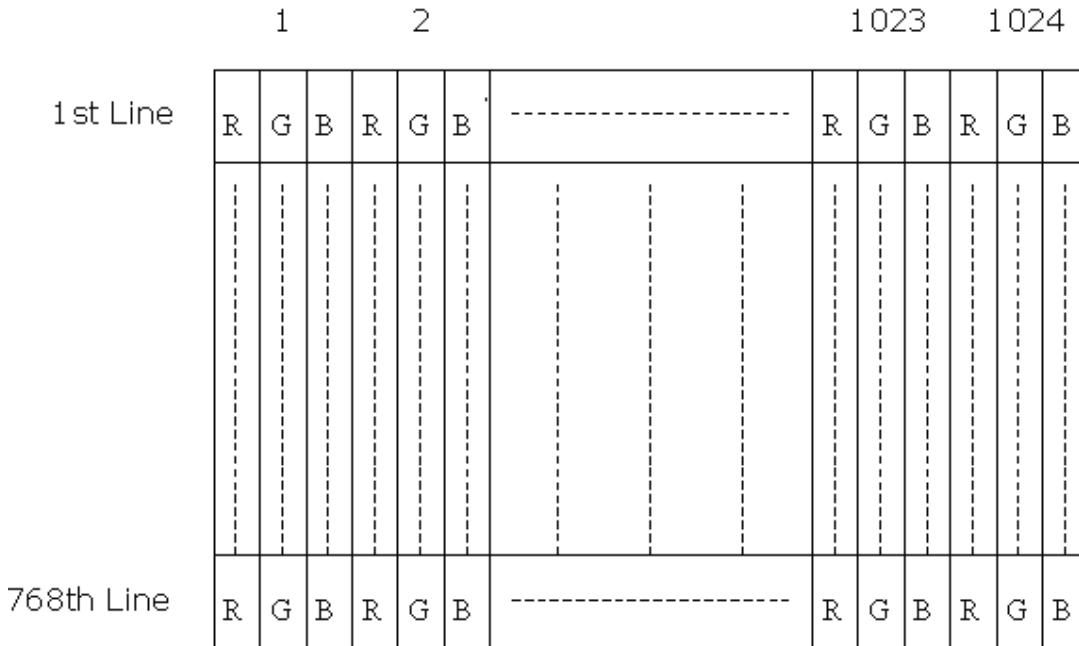

CONFIDENTIAL





## 6.2 The Input Data Format

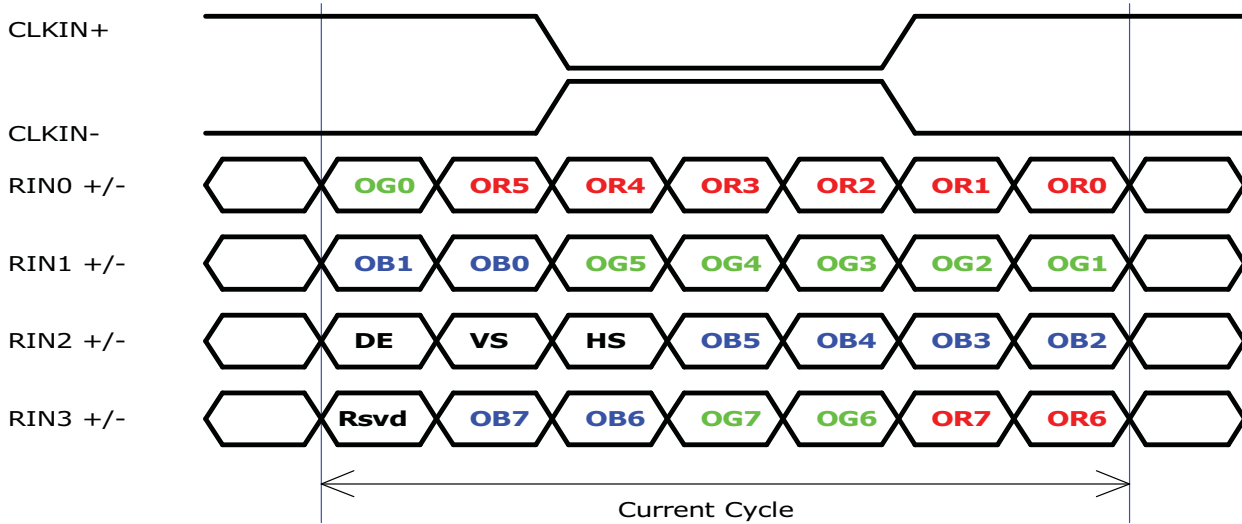

**Note1:** Please follow PSWG.

**Note2:** 8-bit in

**Note3:** R/G/B data 7:MSB, R/G/B data 0:LSB

CONFIDENTIAL



### 6.3 Signal Description

The module using a pair of LVDS receiver SN75LVDS82(Texas Instruments) or compatible. LVDS is a differential signal technology for LCD interface and high speed data transfer device. Transmitter shall be SN75LVDS83(negative edge sampling) or compatible. The first LVDS port(RxOxxx) transmits odd pixels while the second LVDS port(RxExxx) transmits even pixels.

CWY20G-A0D1T (PTWO) or MSB240420 (STM)		
Pin No.	Symbol	Description
1	VDD	Power Supply, 3.3V (typical)
2	VDD	Power Supply, 3.3V (typical)
3	VSS	Ground
4	VSS	Ground
5	Rin0-	- LVDS differential data input (R0-R5, G0)
6	Rin0+	+ LVDS differential data input (R0-R5, G0)
7	VSS	Ground
8	Rin1-	- LVDS differential data input (G1-G5, B0-B1)
9	Rin1+	+ LVDS differential data input (G1-G5, B0-B1)
10	VSS	Ground
11	Rin2-	- LVDS differential data input (B2-B5, HS, VS, DE)
12	Rin2+	+ LVDS differential data input (B2-B5, HS, VS, DE)
13	VSS	<b>Ground</b>
14	ClkIN-	- LVDS differential clock input
15	ClkIN+	+ LVDS differential clock input
16	VSS	Ground
17	Rin3-	- LVDS differential data input (R6-R7, G6-G7, B6-B7)
18	Rin3+	- LVDS differential data input (R6-R7, G6-G7, B6-B7)
19	VSS	Ground
20	VSS	Ground

CONFIDENTIAL



Note1: Start from left side

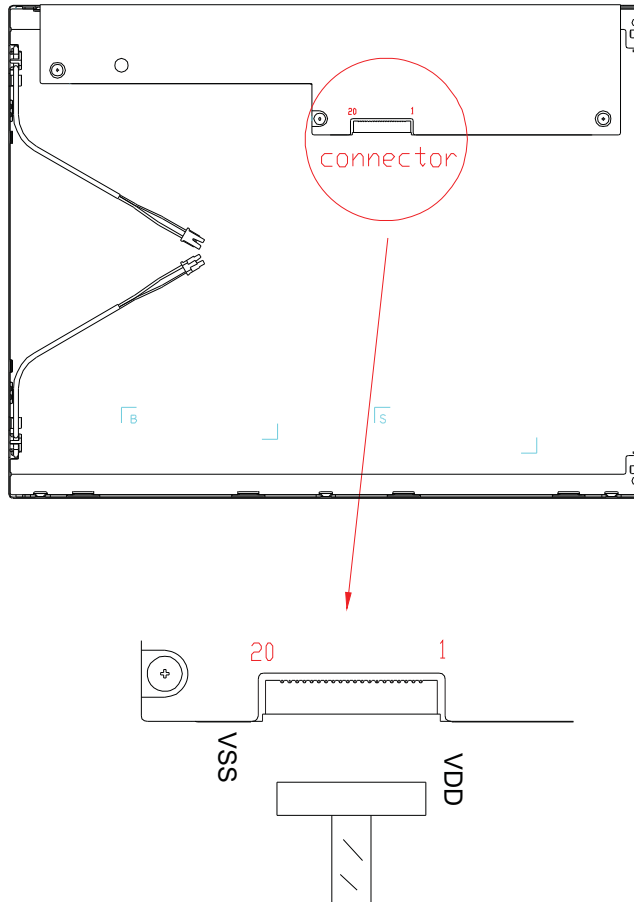

CONFIDENTIAL

Note2: Please follow PSWG.



## 6.4 Interface Timing

### 6.4.1 Timing Characteristics

Signal	Item	Symbol	Min	Typ	Max	Unit
Clock Timing Hsync Timing	Clock frequency	clk	50	65	81	MHz
	Horizontal active	Thd	1024	1024	1024	Tclk
	Horizontal blanking	Thbl	30	320	1024	Tclk
Vsync Timing	Horizontal period	Th	1054	1344	2048	Tck
	Vertical active	Tvd	768	768	768	Th
	Vertical blanking	Tvbl	8	38	256	Th
Clock Timing	Vertical period	Tv	776	806	1024	Th
	Clock frequency	clk	50	65	81	MHz
Hsync Timing	Horizontal active	Thd	1024	1024	1024	Tclk

Note: DE mode only

Note: Typical value refer to VESA STANDARD

CONFIDENTIAL



### 6.4.2 Timing Diagram

CONFIDENTIAL

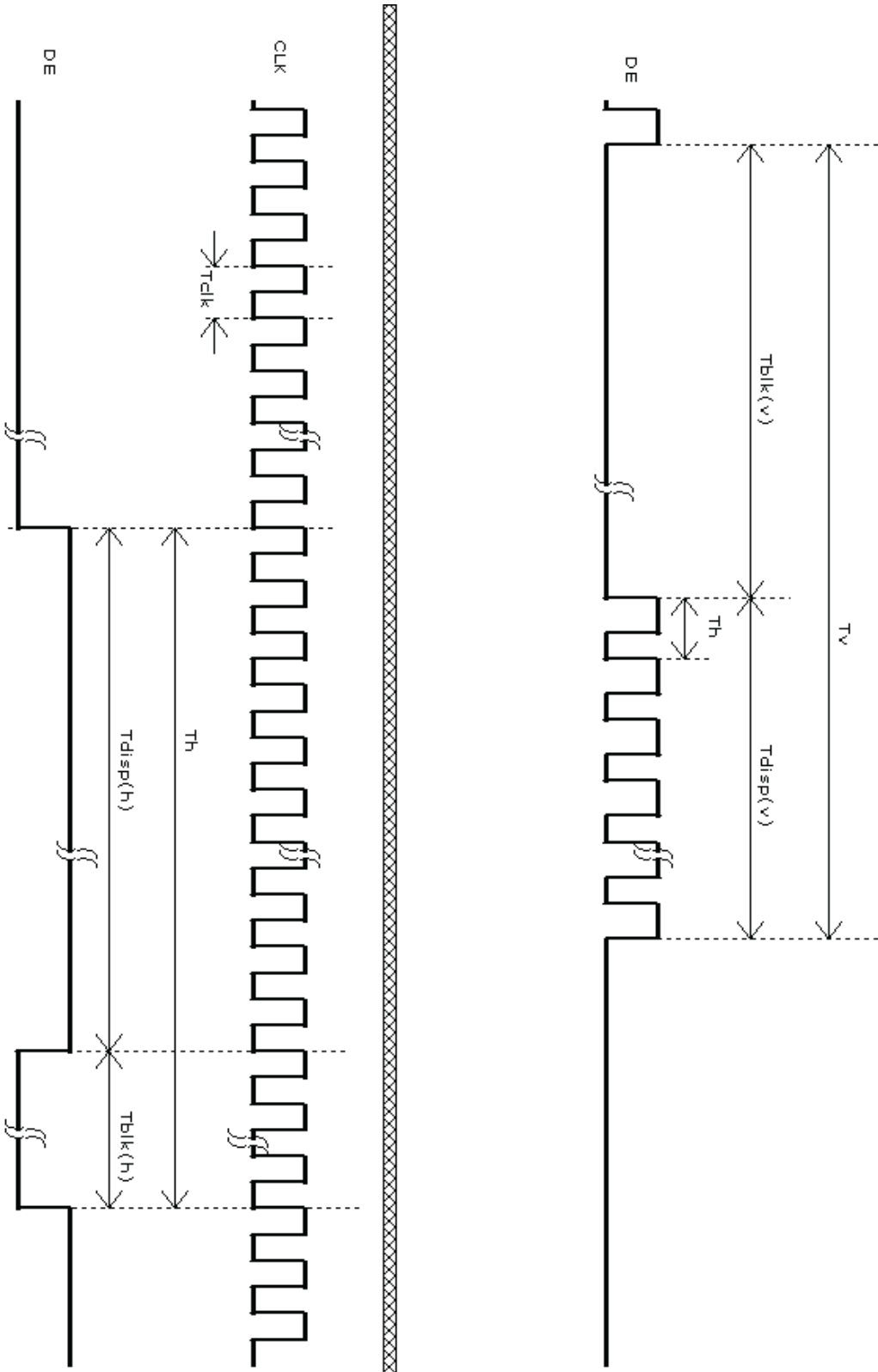

CONFIDENTIAL



### 6.5 Power ON/OFF Sequence

Vin power and lamp on/off sequence is as follows. Interface signals are also shown in the chart. Signals from any system shall be Hi-Z state or low level when Vin is off.

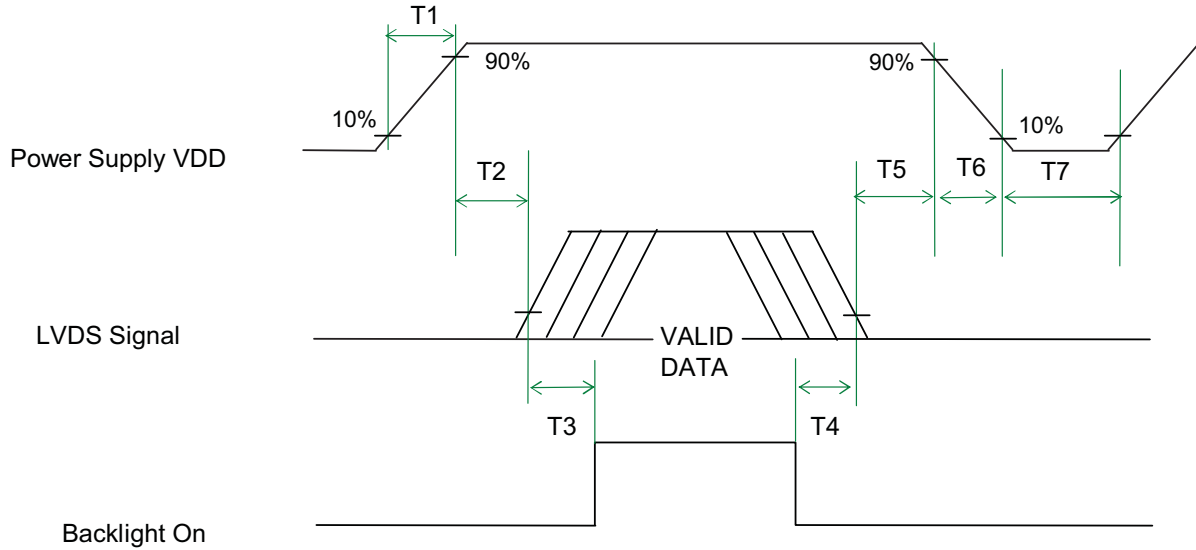

**Power Sequence Timing**

Parameter	Value			Unit
	Min.	Typ.	Max.	
T1	0.5	-	10	[ms]
T2	30	40	50	[ms]
T3	200	-	-	[ms]
T4	100	-	-	[ms]
T5	0	16	50	[ms]
T6	-	-	10	[ms]
T7	1000	-	-	[ms]

CONFIDENTIAL



## 7. Connector & Pin Assignment

Physical interface is described as for the connector on module. These connectors are capable of accommodating the following signals and will be following components.

### 7.1 TFT LCD Module

#### 7.1.1 Connector

Connector Name / Designation	Interface Connector / Interface card
Manufacturer	STM/E&T
Type Part Number	MSB240420E/ 3804-E20N-06R
Mating Housing Part Number	HRS DF14-20S-1.25C

#### 7.1.2 Pin Assignment

Pin#	Signal Name	Pin#	Signal Name
1	VDD	2	VDD
3	VSS	4	VSS
5	Rin0-	6	Rin0+
7	VSS	8	Rin1-
9	Rin1+	10	VSS
11	Rin2-	12	Rin2+
13	VSS	14	ClkIN-
15	ClkIN+	16	VSS
17	Rin3-	18	Rin3+
19	VSS	20	VSS

CONFIDENTIAL





## 7.2 Backlight Unit

Physical interface is described as for the connector on module. These connectors are capable of accommodating the following signals and will be following components.

Connector Name / Designation	Lamp Connector / Backlight lamp
Manufacturer	CviLux
Type Part Number	CP0502SL09
Mating Type Part Number	CP0502P1ML0-LF

### 7.2.1 Signal for Lamp connector

	Connector No.	Pin No.	Input	Color	Function
Upper	CN1	1	Hot1	Pink	High Voltage
		2	Cold1	White	Low Voltage

	Connector No.	Pin No.	Input	Color	Function
Lower	CN2	1	Hot1	Pink	High Voltage
		2	Cold1	White	Low Voltage

CONFIDENTIAL



## 8. Reliability Test

Environment test conditions are listed as following table.

Items	Required Condition	Note
Temperature Humidity Bias (THB)	Ta= 50°C, 80%RH, 300hours	
High Temperature Operation (HTO)	Ta= 50°C, 300hours	
Low Temperature Operation (LTO)	Ta= 0°C, 300hours	
High Temperature Storage (HTS)	Ta= 60°C, 300hours	
Low Temperature Storage (LTS)	Ta= -20°C, 300hours	
Vibration Test (Non-operation)	Acceleration: 1.5 G Wave: Random Frequency: 10 - 200 - 10 Hz Sweep: 30 Minutes each Axis (X, Y, Z)	
Shock Test (Non-operation)	Acceleration: 50 G Wave: Half-sine Active Time: 20 ms Direction: ±X, ±Y, ±Z (one time for each Axis)	
Drop Test	Height: 60 cm, package test	
Thermal Shock Test (TST)	-20°C/30min, 60°C/30min, 100 cycles	1
On/Off Test	On/10sec, Off/10sec, 30,000 cycles	
ESD (Electro Static Discharge)	Contact Discharge: ± 8KV, 150pF(330Ω ) 1sec, 8 points, 25 times/ point.	2
	Air Discharge: ± 15KV, 150pF(330Ω ) 1sec 8 points, 25 times/ point.	
Altitude Test	Operation:10,000 ft Non-Operation:30,000 ft	

Note 1: The TFT-LCD module will not sustain damage after being subjected to 100 cycles of rapid temperature change. A cycle of rapid temperature change consists of varying the temperature from -20°C to 60°C, and back again. Power is not applied during the test. After temperature cycling, the unit is placed in normal room ambient for at least 4 hours before power on.

Note 2: According to EN61000-4-2, ESD class B: Some performance degradation allowed. No data lost. Self-recoverable. No hardware failures.

CONFIDENTIAL



### 9. Shipping Label

The shipping label format is shown as below.



CONFIDENTIAL

10. Mechanical Characteristics

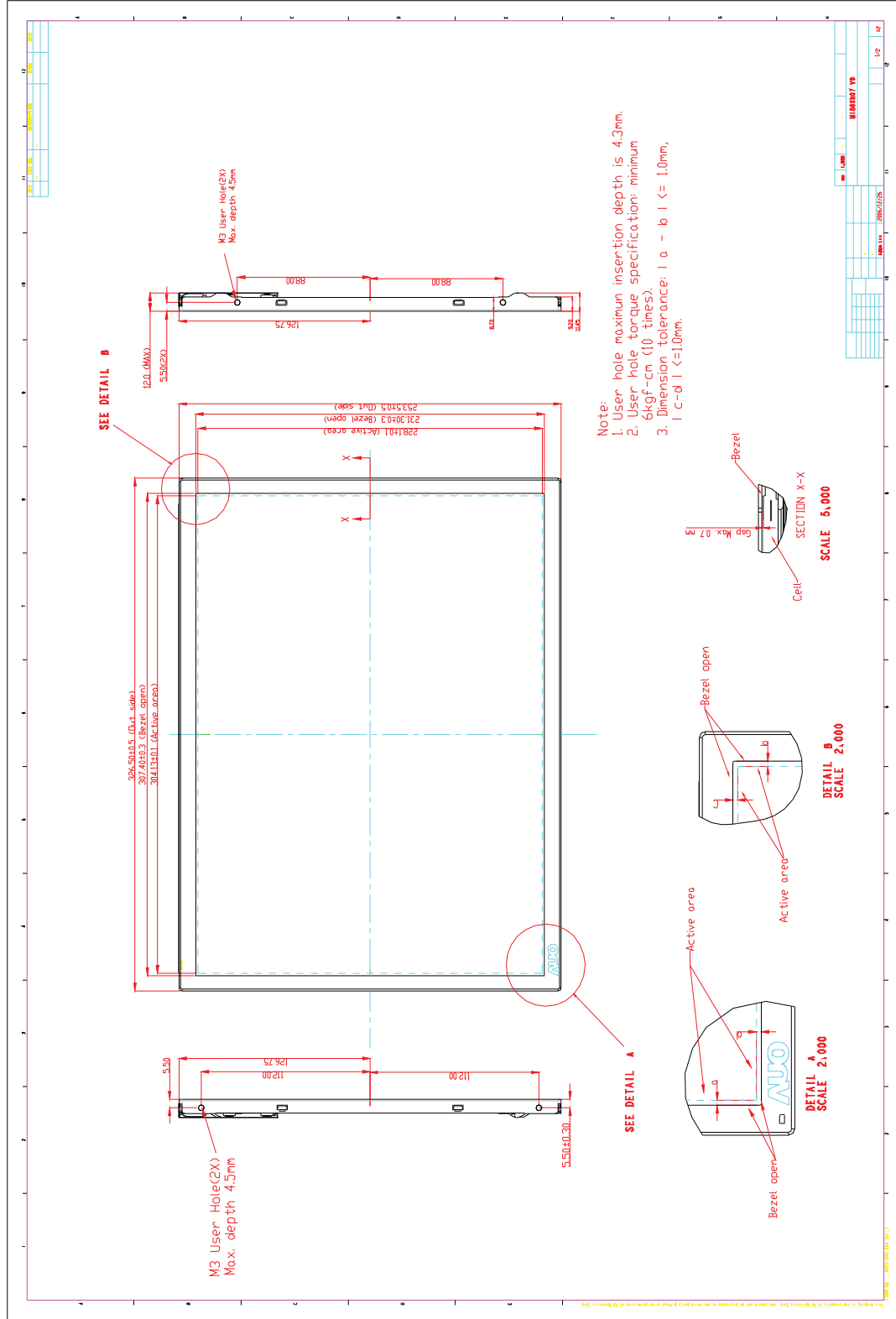

CONFIDENTIAL



# Product Specification

AU OPTONICS CORPORATION

M150XN07 V9

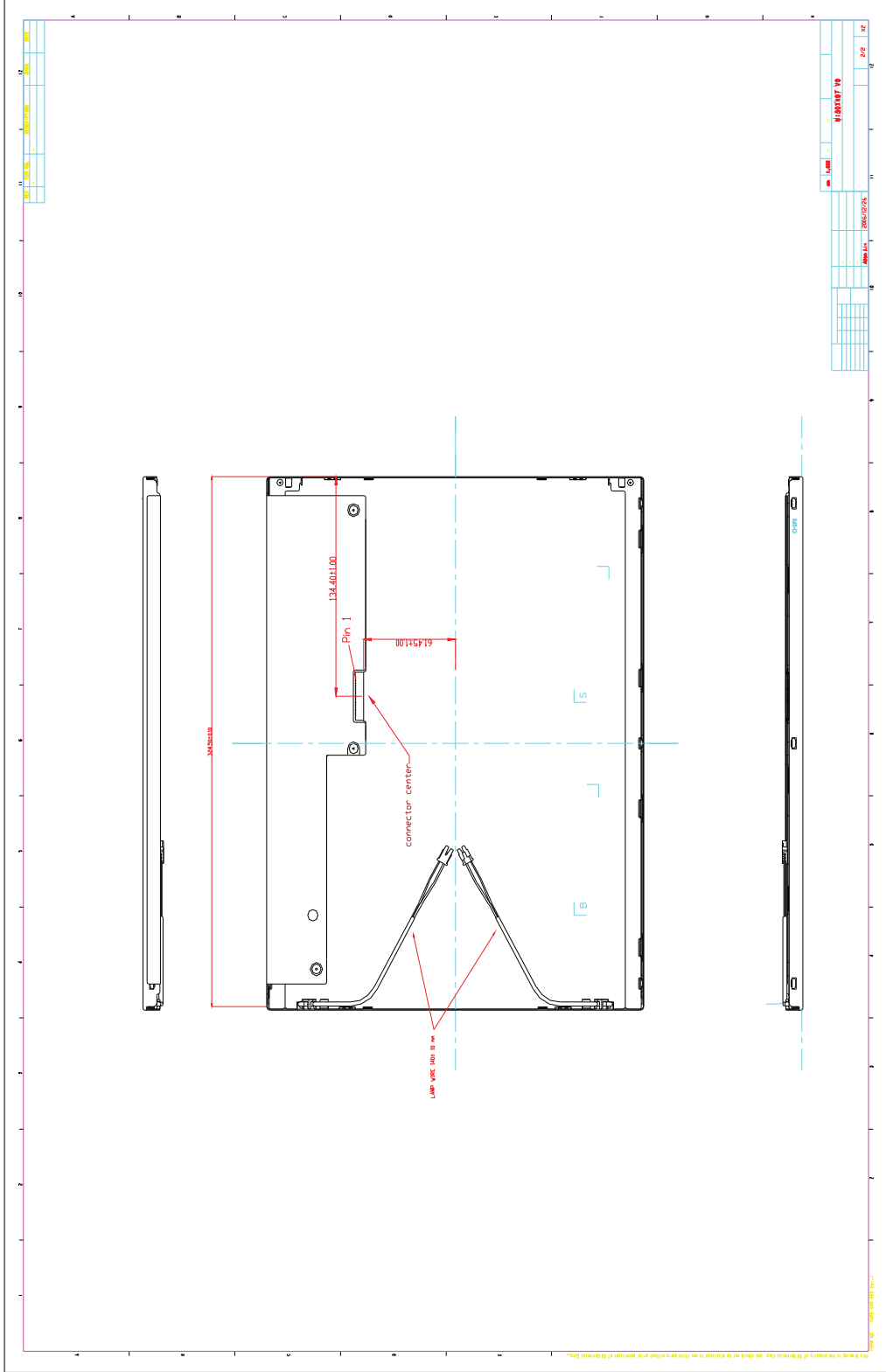

29/27

document version 0.1



# US Micro Products

*Electronic Products for the OEM*

Los Angeles • Austin • New York • Orlando • Shenzhen

(800) 741-7755

[www.usmicroproducts.com](http://www.usmicroproducts.com)

## Displays

US Micro Products is an industrial distributor specializing in engineered display solutions. We dedicate ourselves to providing the best in displays for the medical, industrial, gaming, automotive, aerospace, military, and consumer markets.

### OLEDs



### TFT Displays



### Open Frame Monitors



### Passive LCDs



### Multitouch



As a customer, you benefit from our expert knowledge, support and service which allow quick selection and design-in of the best display for your application. On hand stock and demo boards facilitate quick access and evaluation to get you going fast. Our technical sales staff and experienced design engineers provide answers to your questions as well as engineered solutions to solve your display needs.

## Peripheral Devices

Our full line of peripheral devices includes keyboards, trackballs, and printers. These rugged industrial products are designed to meet your demanding requirements and are available as both standard and custom solutions.

### Keyboards



### Trackballs



### Aerospace Trackballs



### Joysticks



### Printers

