



US Micro Products
Electronic Products for the OEM

TFT-LCD PRODUCT SPECIFICATION

Manufactured by



PART NUMBER:	USMP-G190EG01 V0
DESCRIPTION:	19" TFT LCD with SXGA (1280(H) x 1024(V)) screen and 16.7M colors (RGB 6-bits + HiFRC data).

ISSUE DATE	APPROVED BY (Customer Use Only)	CHECKED BY	PREPARED BY
PROPRIETARY NOTE:	THIS SPECIFICATION IS THE PROPERTY OF US MICRO PRODUCTS AND SHALL NOT BE REPRODUCED OR COPIED WITHOUT THE WRITTEN PERMISSION OF US MICRO PRODUCTS AND MUST BE RETURNED TO US MICRO PRODUCTS UPON ITS REQUEST.		



Contents

1. Handling Precautions	4
2. General Description	5
2.1 Display Characteristics	6
3. Functional Block Diagram.....	11
4. Absolute Maximum Ratings.....	12
4.1 Absolute Ratings of TFT LCD Module	12
4.2 Absolute Ratings of Backlight Unit	12
4.3 Absolute Ratings of Environment	12
5. Electrical characteristics	14
5.1 TFT LCD Module	14
5.2 Backlight Unit.....	16
6. Signal Characteristic	17
6.1 Pixel Format Image	17
6.2 The Input Data Format	18
6.4 Interface Timing.....	20
6.5 Power ON/OFF Sequence.....	23
7. Connector & Pin Assignment	24
7.1 TFT LCD Module	24
7.2 Backlight Unit.....	25
8. Reliability Test.....	26
9. Shipping Label.....	錯誤! 尚未定義書籤。
10. Mechanical Characteristic	28

CONFIDENTIAL

AUO Confidential For AUO Internal Use Only / 2009/11/18



Record of Revision

Version & Date	Page	Old Description	New Description	Remark
0.1 2009/11/13	All	Frist Edition for Customer		

CONFIDENTIAL

AUO Confidential For AUO Internal Use Only / 2009/11/18



1. Handling Precautions

- 1) Since front polarizer is easily damaged, pay attention not to scratch it.
- 2) Be sure to turn off power supply when inserting or disconnecting from input connector.
- 3) Wipe off water drop immediately. Long contact with water may cause discoloration or spots.
- 4) When the panel surface is soiled, wipe it with absorbent cotton or other soft cloth.
- 5) Since the panel is made of glass, it may break or crack if dropped or bumped on hard surface.
- 6) Since CMOS LSI is used in this module, take care of static electricity and insure human earth when handling.
- 7) Do not open or modify the Module Assembly.
- 8) Do not press the reflector sheet at the back of the module to any directions.
- 9) In case if a Module has to be put back into the packing container slot after once it was taken out from the container, do not press the center of the Cold Cathode Fluorescent Lamp (CCFL) reflector edge. Instead, press at the far ends of the CCFL reflector edge softly. Otherwise the TFT Module may be damaged.
- 10) At the insertion or removal of the Signal Interface Connector, be sure not to rotate nor tilt the Interface Connector of the TFT Module.
- 11) After installation of the TFT Module into an enclosure, do not twist nor bend the TFT Module even momentary. At designing the enclosure, it should be taken into consideration that no bending/twisting forces are applied to the TFT Module from outside. Otherwise the TFT Module may be damaged.
- 12) Cold Cathode Fluorescent Lamp (CCFL) in LCD contains a small amount of mercury. Please follow local ordinances or regulations for disposal.
- 13) Small amount of materials having no flammability grade is used in the LCD module. The LCD module should be supplied by power complied with requirements of Limited Power Source (IEC60950 or UL1950), or be applied exemption.
- 14) The LCD module is designed so that the CCFL in is supplied by Limited Current Circuit (IEC60950 or UL1950). Do not connect the CCFL in Hazard Voltage Circuit.

CONFIDENTIAL

AUO Confidential For AUO Internal Use Only 2009/11/18



2. General Description

G190EG01 V0 is a Color Active Matrix Liquid Crystal Display composed of a TFT-LCD panel, a driver circuit, and a backlight system. The screen format is intended to support the SXGA (1280(H) x 1024(V)) screen and 16.7M colors (RGB 6-bits + HiFRC data). All input signals are 2-channel LVDS interface compatible. Inverter card of backlight is not included.

CONFIDENTIAL

AUO Confidential For AUO Internal Use Only / 2009/11/18



2.1 Display Characteristics

The following items are characteristics summary on the table under 25 °C condition:

Items	Unit	Specifications
Screen Diagonal	[mm]	482.6 (19.0")
Active Area	[mm]	376.32 (H) x 301.06 (V)
Pixels H x V		1280(x3) x 1024
Pixel Pitch	[mm]	0.294 (per one triad) x 0.294
Pixel Arrangement		R.G.B. Vertical Stripe
Display Mode		Normally White
White Luminance	[cd/m ²]	400 (center, Typ) @ 7.5mA
Contrast Ratio		1000 : 1 (Typ)
Optical ResponseTime	[msec]	5 ms(Typ, on/off)
Nominal Input Voltage VDD	[Volt]	+5.0 V
Power Consumption	[Watt]	26.71 W (Typ) (PDD= 5.5 W, @Lamp=7.5mA)
Weight	[Grams]	2500 (Typ)
Physical Size (H x V x D)	[mm]	396 (H) x 324 (V) x 18.5 (D) (Typ)
Electrical Interface		Dual channel LVDS
Surface Treatment		Hard-coating (3H), Non-Glare treatment
Support Color		16.7M colors (RGB 6-bit data + HiFRC data)
Temperature Range		
Operating	[°C]	0 to +50
Storage (Non-Operating)	[°C]	-20 to +60
RoHS Compliance		RoHS Compliance

CONFIDENTIAL

AUO Confidential For AUO Internal Use Only 2003/12/16



2.2 Optical Characteristics

The optical characteristics are measured under stable conditions at 25°C (Room Temperature):

Item	Unit	Conditions	Min.	Typ.	Max.	Note
Viewing Angle	[degree]	Horizontal (Right) CR = 10 (Left)	75 75	85 85	-	1
		Vertical (Up) CR = 10 (Down)	70 70	80 80	-	
		Horizontal (Up) CR = 5 (Down)	75 75	85 85	-	
		Vertical (Up) CR = 5 (Down)	75 75	85 85	-	
Luminance Uniformity	[%]	9 Points	75	80	-	2, 3
Optical Response Time	[msec]	Rising	-	3.6	5.7	4, 6
		Falling	-	1.4	2.3	
		Rising + Falling	-	5	8	
Color / Chromaticity Coordinates (CIE)		Red x	0.617	0.647	0.677	4
		Red y	0.310	0.340	0.370	
		Green x	0.258	0.288	0.318	
		Green y	0.575	0.605	0.635	
		Blue x	0.115	0.145	0.175	
		Blue y	0.041	0.071	0.101	
		White x	0.283	0.313	0.343	
White y	0.299	0.329	0.359			
White Luminance (At CCFL= 7.5mA)	[cd/m ²]		320	400	-	4
Contrast Ratio			600	1000	-	4
Cross Talk (At 60Hz)	[%]		-	-	1.5	5
Flicker	[dB]		-	-	-20	7

CONFIDENTIAL

AUO Confidential For AUO Internal Use Only / 2009/7/14/8

Note 1: Definition of viewing angle, measured by ELDIM (EZContrast 88)

Viewing angle is the measurement of contrast ratio ≥ 10 , or ≥ 5 , at the screen center, over a 180° horizontal and 180° vertical range (off-normal viewing angles). The 180° viewing angle range is broken down as follows; 90° (θ) horizontal left and right and 90° (Φ) vertical, high (up) and low (down). The measurement direction is typically perpendicular to the display surface with the screen rotated about its center to develop the desired measurement viewing angle.

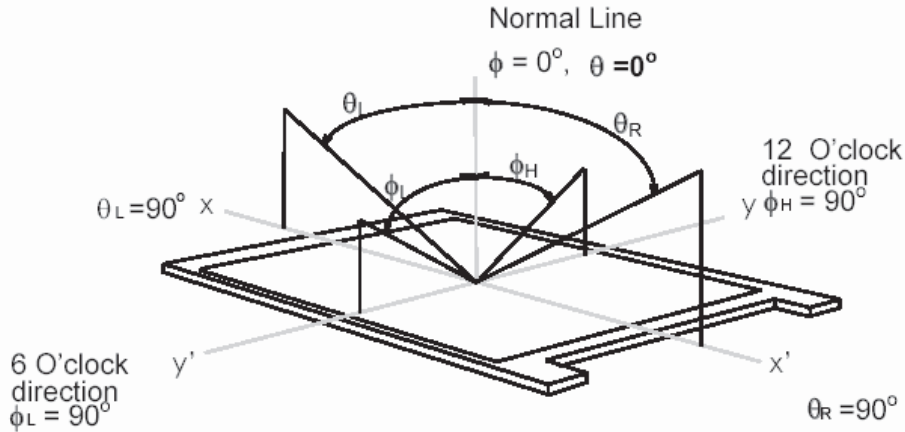

Note 2: 9 points position

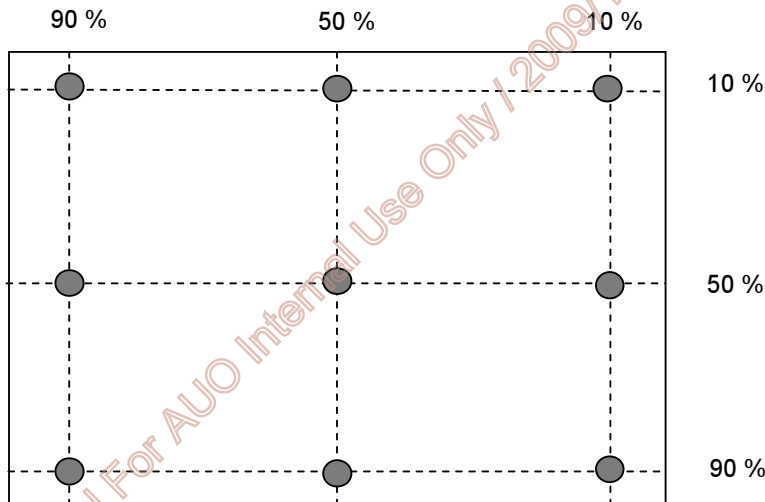

Note 3: The luminance uniformity of 9 points is defined by dividing the maximum luminance values by the minimum test point luminance. And measured by TOPCON SR-3

$$\delta_{w9} = \frac{\text{Minimum Luminance of 9 points}}{\text{Maximum Luminance of 9 points}}$$

CONFIDENTIAL

AUO Confidential For AUO Internal Use Only / 2009/11/18

Note 4: Measurement method

The LCD module should be stabilized at given temperature for 30 minutes to avoid abrupt temperature change during measuring. In order to stabilize the luminance, the measurement should be executed after lighting Backlight for 30 minutes in a stable, windless and dark room.

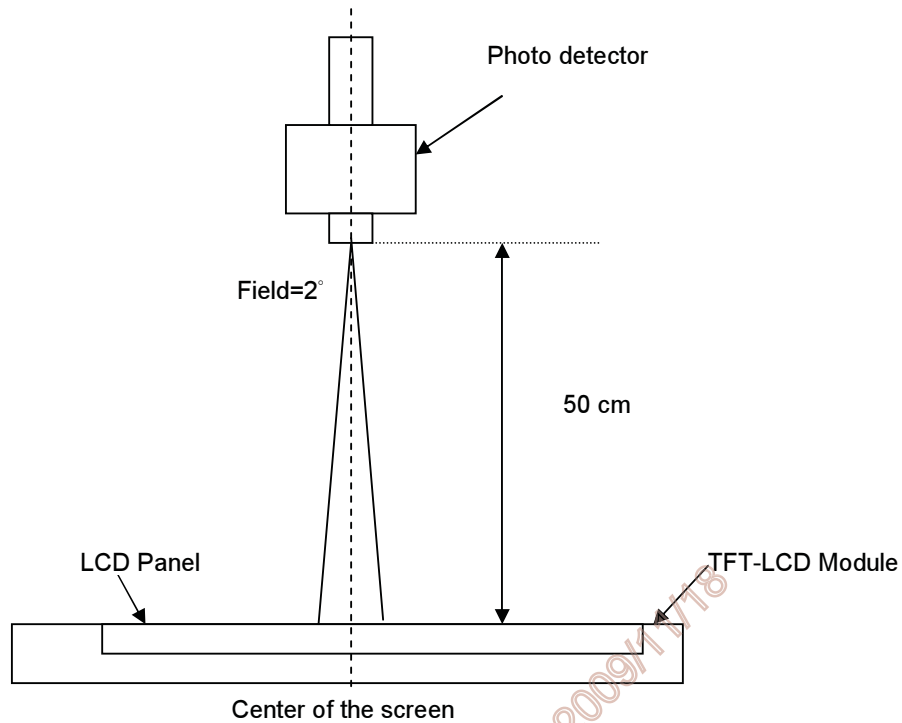

Note 5: Definition of Cross Talk (CT) and measured by TOPCON SR-3

$$CT = |Y_B - Y_A| / Y_A \times 100 (\%)$$

Where

Y_A = Luminance of measured location without gray level 0 pattern (cd/m²)

Y_B = Luminance of measured location with gray level 0 pattern (cd/m²)

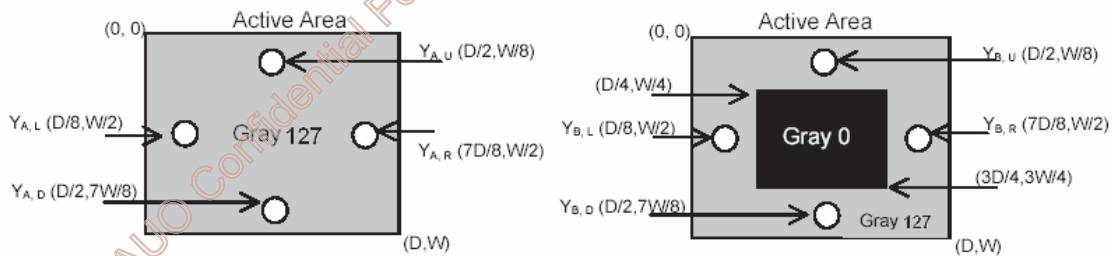

Note 6: Definition of response time, measured by WESTAR TRD-100A

The output signals of photo detector are measured when the input signals are changed from "Full Black" to "Full White" (rising time), and from "Full White" to "Full Black" (falling time), respectively. The response time is interval between the 10% and 90% of amplitudes. Please refer to the figure as below.

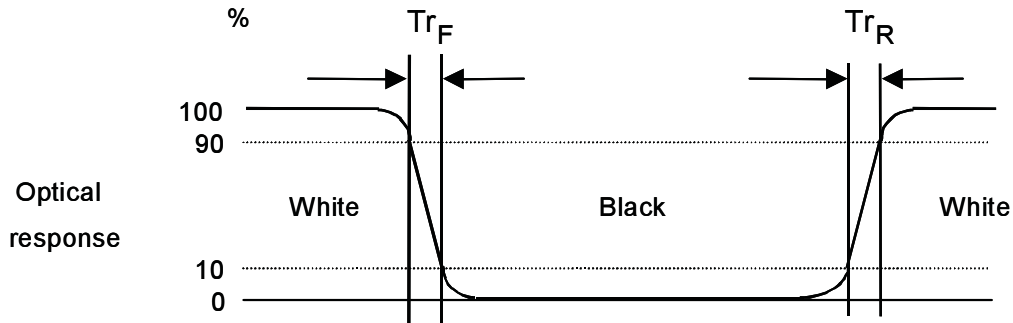

Note 7: Subchecker Pattern

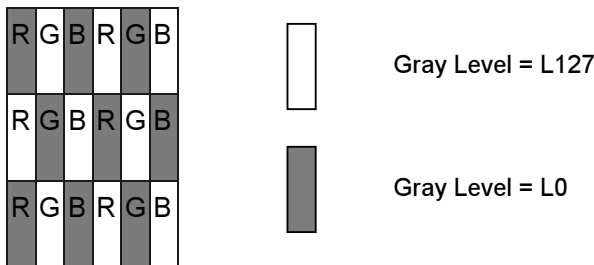

Method: Record dBV & DC value with (WESTAR)TRD-100

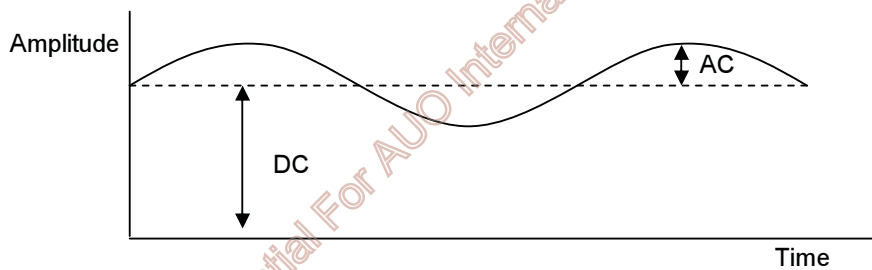

$$\text{Flicker (dB)} = 20 \log \frac{\text{AC Level (at 30 Hz)}}{\text{DC Level}}$$

CONFIDENTIAL

AUO Confidential For AUO Internal Use Only / 2009/11/18

3. Functional Block Diagram

The following diagram shows the functional block of the 19.0 inches Color TFT-LCD Module:

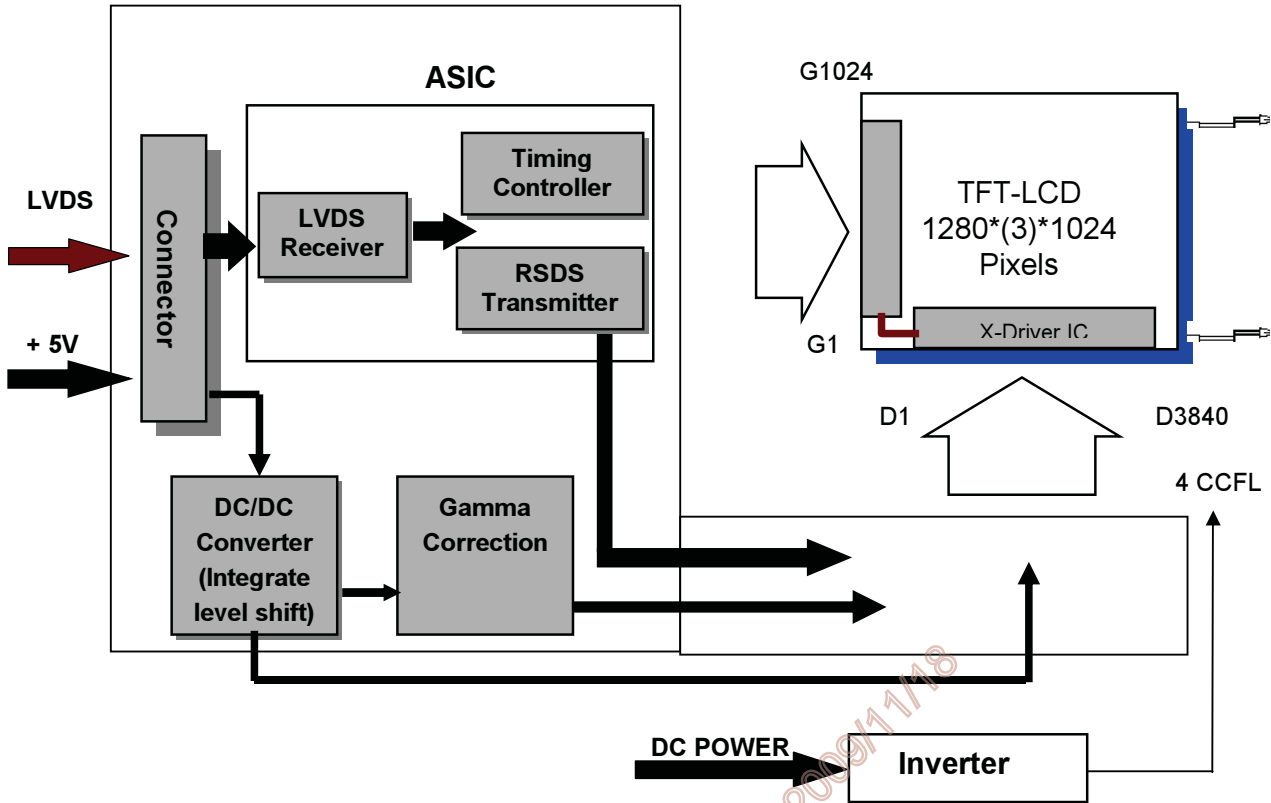

I/F PCB Interface:

FI-XB30SSL-HF15 / MSBKT2407P30HB

Mating Type:

FI-X30HL (Locked Type)

FI-X30H (Unlocked Type)

CONFIDENTIAL

AUO Confidential For AUO Internal Use Only / 2009/11/18



4. Absolute Maximum Ratings

Absolute maximum ratings of the module are as following:

4.1 Absolute Ratings of TFT LCD Module

Item	Symbol	Min.	Max.	Unit	Conditions
Logic/LCD Drive Voltage	VDD	-0.3	+6	[Volt]	Note 1, 2

4.2 Absolute Ratings of Backlight Unit

Item	Symbol	Min.	Max.	Unit	Conditions
CCFL Current	ICFL	-	8	[mA] rms	Note 1, 2

4.3 Absolute Ratings of Environment

Item	Symbol	Min.	Max.	Unit	Conditions
Operating Temperature	TOP	0	+50	[°C]	Note 3
Operation Humidity	HOP	5	90	[%RH]	
Storage Temperature	TST	-20	+60	[°C]	
Storage Humidity	HST	5	90	[%RH]	

CONFIDENTIAL

AUO Confidential For AUO Internal Use Only / 200917118





Note 1: With in $T_a = 25^\circ\text{C}$

Note 2: Permanent damage to the device may occur if exceed maximum values

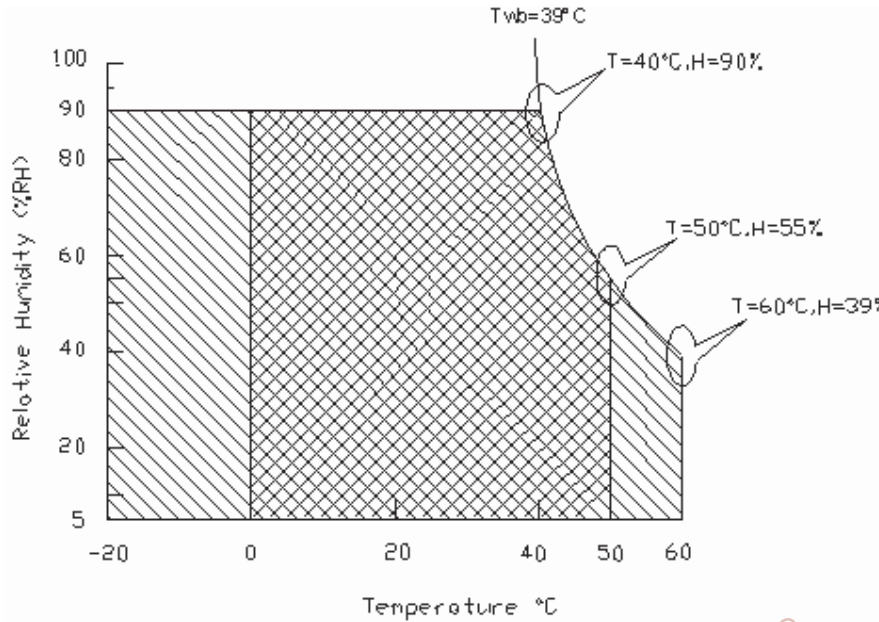
Note 3: For quality performance, please refer to AUO IIS (Incoming Inspection Standard).



Operating Range  Storage Range  + 

CONFIDENTIAL

AUO Confidential For AUO Internal Use Only / 2009/11/18

5. Electrical characteristics

5.1 TFT LCD Module

5.1.1 Power Specification

Input power specifications are as follows:

Symbol	Parameter	Min	Typ	Max	Unit	Condition
VDD	Logic/LCD Drive Voltage	4.50	5.00	5.50	[Volt]	±10%
IDD	Input Current	-	1.10	1.31	[A]	VDD= 5.0V, All black Pattern, At 60Hz
IDD	Input Current	-	1.37	1.63	[A]	VDD= 5.0V, H-Stripe Pattern, At 75Hz Note1
PDD	VDD Power	-	5.50	6.55	[Watt]	VDD= 5.0V, All black Pattern, At 60Hz
PDD	VDD Power	-	6.85	8.15	[Watt]	VDD= 5.0V, H-Stripe Pattern, At 75Hz
IRush	Inrush Current	-	-	2.5	[A]	Note2
VDDrp	Allowable Logic/LCD Drive Ripple Voltage	-	-	100	[mV] p-p	VDD= 5.0V, All black Pattern, At 75Hz

Note 1: The H-Stripe pattern is defined as below :

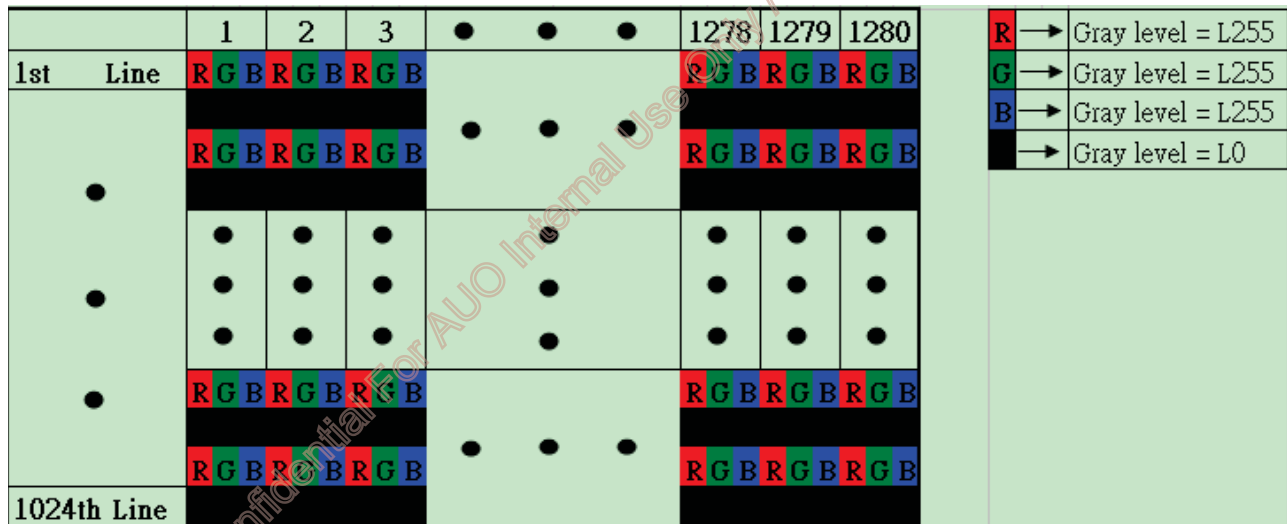

CONFIDENTIAL

Note 2: Measurement conditions:

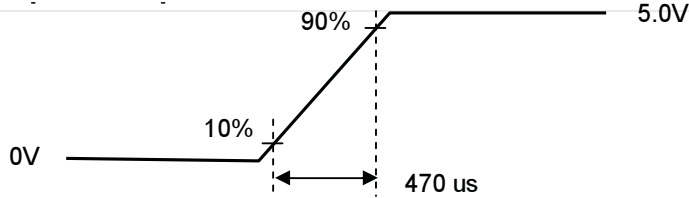
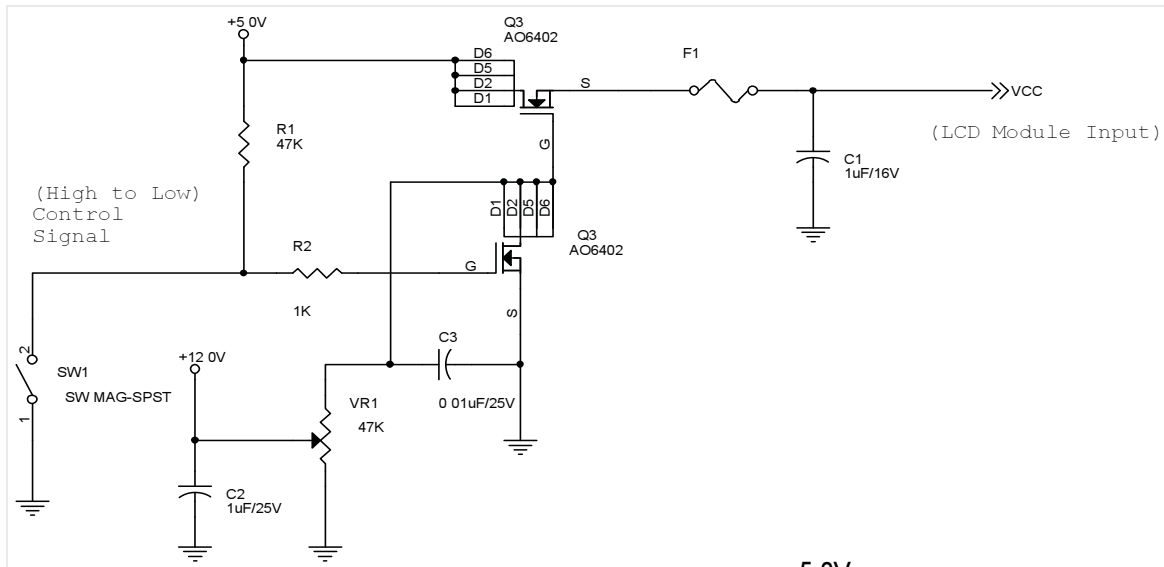

Vin rising time

CONFIDENTIAL

AUO Confidential For AUO Internal Use Only / 2009/11/18



5.2 Backlight Unit

Parameter guideline for CCFL Inverter is under stable conditions at 25°C (Room Temperature):

Parameter	Min.□	Typ.	Max.□	Unit	Condition
CCFL Standard Current(ISCFL)	7.0	7.5	8.0	[mA] rms	Note 2
CCFL Operation Current(IRCFL)	3.0□	7.5	8.0	[mA] rms	Note 2
CCFL Frequency(FCFL)	40	60	80	[KHz]	Note 3,4
CCFL Ignition Voltage(ViCFL, Ta= 0°C)		1200	1440	[Volt] rms	Note 5
CCFL Ignition Voltage(ViCF, Ta= 25°C)		1000	1200	[Volt] rms	
CCFL Operation Voltage (VCFL)	-	707 (@ 7.5mA)	-	[Volt] rms	Note 6
CCFL Power Consumption(PCFL)	-	21.21	-	[Watt]	Note 6
CCFL Life Time(LTCFL)	50,000	-	-	[Hour]	Note 7

Note 1: Typ. are AUO recommended design points.

- *1 All of characteristics listed are measured under the condition using the AUO test inverter.
- *2 In case of using an inverter other than listed, it is recommended to check the inverter carefully. Sometimes, interfering noise stripes appear on the screen, or substandard luminance or flicker at low power may happen.
- *3 In designing an inverter, it is suggested to check safety circuit very carefully. Impedance of CCFL, for instance, becomes more than 1 [M ohm] when CCFL is damaged.
- *4 Generally, CCFL has some amount of delay time after applying kick-off voltage. It is recommended to keep on applying kick-off voltage for 1 [Sec] until discharge.
- *5 Reducing CCFL current increases CCFL discharge voltage and generally increases CCFL discharge frequency. So all the parameters of an inverter should be carefully designed so as not to produce too much leakage current from high-voltage output of the inverter.

Note 2: CCFL standard current is measured at 25±2°C.

Note 3: CCFL discharge frequency should be carefully determined to avoid interference between inverter and TFT LCD.

Note 4: The frequency range will not affect to lamp life and reliability characteristics.

Note 5: CCFL inverter should be able to give out a power that has a generating capacity of over 1,200 voltage. Lamp units need 1,200 voltage minimum for ignition.

Note 6: The variance of CCFL power consumption is ±10%. Calculator value for reference (ISCFL × VCFL × 4 = PCFL)

Note 7: Definition of life: brightness becomes 50%. The typical life time of CCFL is on the condition at 7.5 mA lamp output current.



6. Signal Characteristic

6.1 Pixel Format Image

Following figure shows the relationship of the input signals and LCD pixel format.

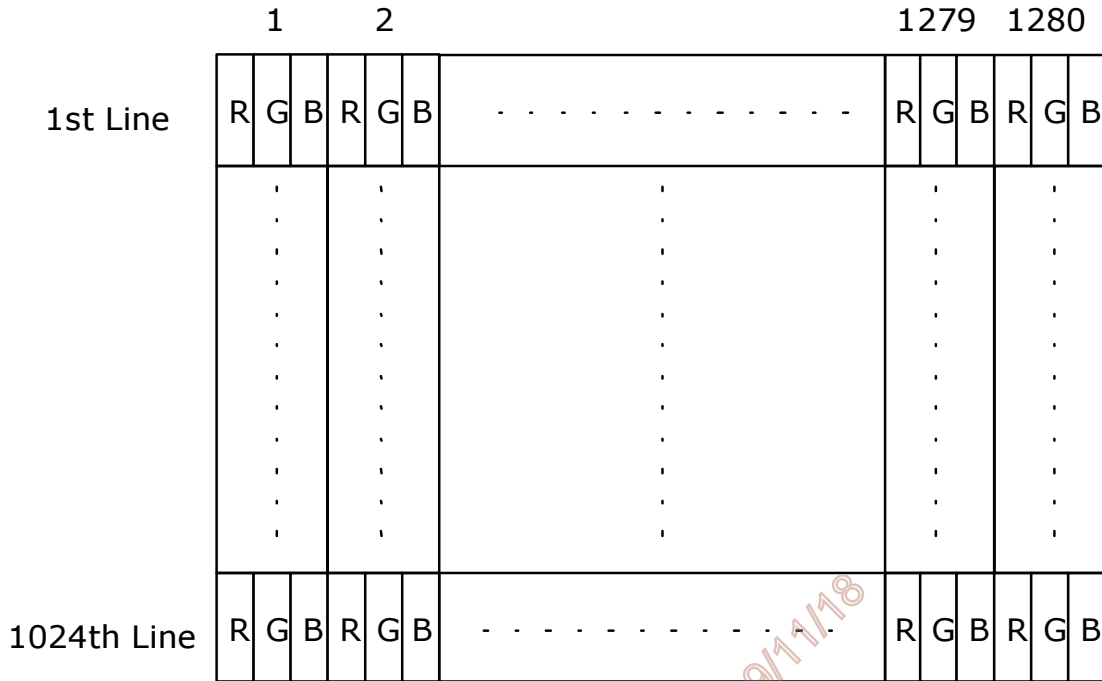

CONFIDENTIAL

AUO Confidential For AUO Internal Use Only / 2009/11/18

6.2 The Input Data Format

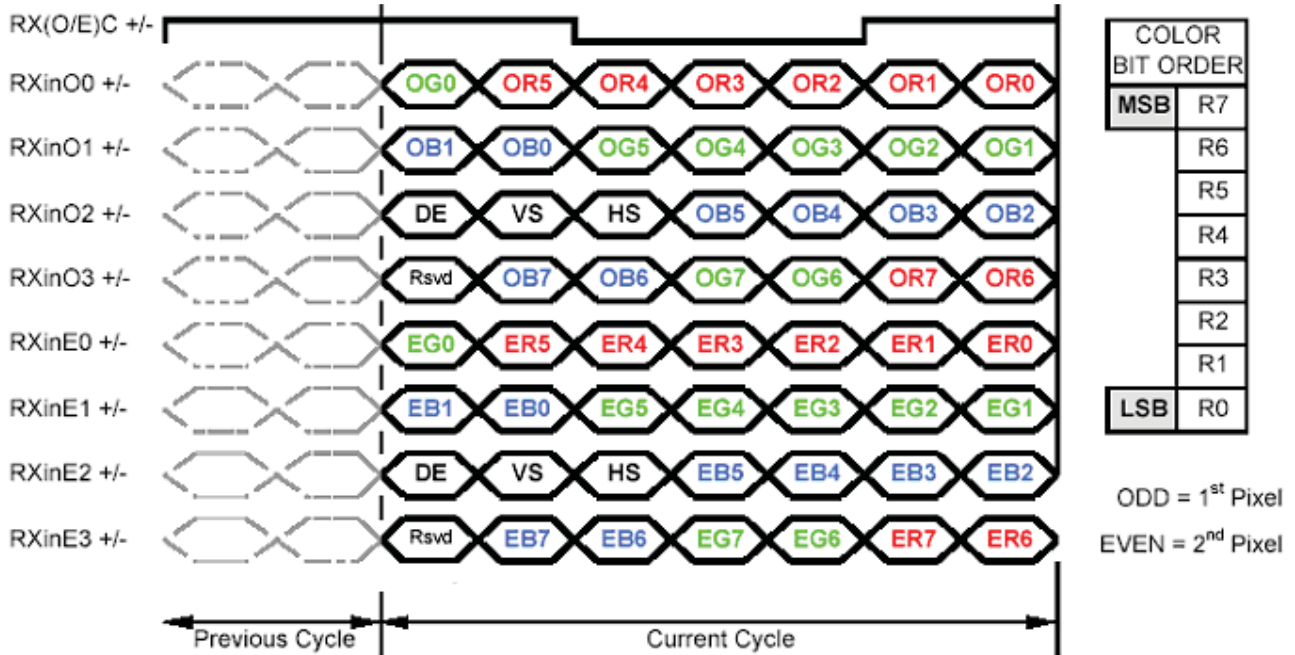

Note1: Normally DE mode only. VS and HS on EVEN channel are not used.

Note2: Please follow VESA.

Note3: 8-bit in

CONFIDENTIAL

AUO Confidential For AUO Internal Use Only / 2009/11/18



6.3 Signal Description

The module using a pair of LVDS receiver SN75LVDS82(Texas Instruments) or compatible. LVDS is a differential signal technology for LCD interface and high speed data transfer device. Transmitter shall be SN75LVDS83(negative edge sampling) or compatible. The first LVDS port(RxOxxx) transmits odd pixels while the second LVDS port(RxExxx) transmits even pixels.

PIN #	SIGNAL NAME	DESCRIPTION
1	RxOIN0-	Negative LVDS differential data input (Odd data)
2	RxOIN0+	Positive LVDS differential data input (Odd data)
3	RxOIN1-	Negative LVDS differential data input (Odd data)
4	RxOIN1+	Positive LVDS differential data input (Odd data)
5	RxOIN2-	Negative LVDS differential data input (Odd data, H-Sync,V-Sync,DSPTMG)
6	RxOIN2+	Positive LVDS differential data input (Odd data, H-Sync,V-Sync,DSPTMG)
7	VSS	Power Ground
8	RxOCLKIN-	Negative LVDS differential clock input (Odd clock)
9	RxOCLKIN+	Positive LVDS differential clock input (Odd clock)
10	RxOIN3-	Negative LVDS differential data input (Odd data)
11	RxOIN3+	Positive LVDS differential data input (Odd data)
12	RxEIN0-	Negative LVDS differential data input (Even data)
13	RxEIN0+	Positive LVDS differential data input (Even data)
14	VSS	Power Ground
15	RxEIN1-	Negative LVDS differential data input (Even data)
16	RxEIN1+	Positive LVDS differential data input (Even data)
17	VSS	Power Ground
18	RxEIN2-	Negative LVDS differential data input (Even data)
19	RxEIN2+	Positive LVDS differential data input (Even data)
20	RxECLKIN-	Negative LVDS differential clock input (Even clock)
21	RxECLKIN+	Positive LVDS differential clock input (Even clock)
22	RxEIN3-	Negative LVDS differential data input (Even data)
23	RxEIN3+	Positive LVDS differential data input (Even data)
24	VSS	Power Ground
25	VSS	Power Ground
26	NC	Do not connect (for AUO test)
27	VSS	Power Ground
28	VCC	+5.0V Power Supply
29	VCC	+5.0V Power Supply
30	VCC	+5.0V Power Supply

CONFIDENTIAL

Note1: Start from left side

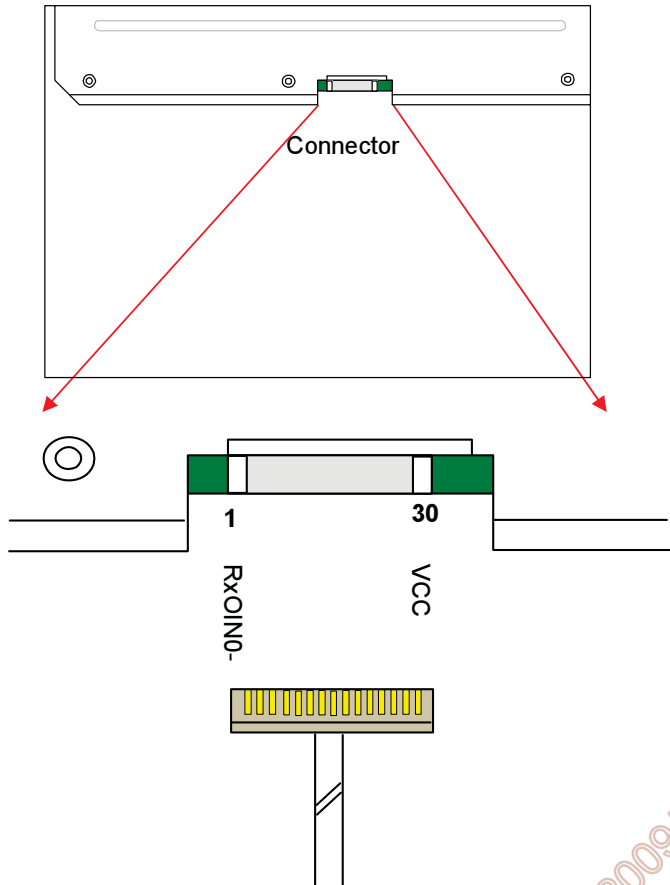

Note2: Input signals of odd and even clock shall be the same time.

Note3: Please follow VESA.

CONFIDENTIAL

6.4 Interface Timing

6.4.1 Timing Characteristics

Signal	Item	Symbol	Min	Typ	Max	Unit
Vertical Section	Period	T_v	1032	1066	1150	Th
	Active	$T_{disp(v)}$	1024	1024	1024	Th
	Blanking	$T_{bp(v)}+T_{fp(v)}+PWVs$	8	42	126	Th



Horizontal Section	Period	Th	780	844	2047	Tclk
	Active	Tdisp(h)	640	640	640	Tclk
	Blanking	Tbp(h)+Tfp(h)+PWhs	140	204	-	Tclk
Clock	Period	Tclk	22.2	18.52	14.81	ns
	Frequency	Freq.	45	54	67.5	MHz
Frame Rate	Frequency	1/Tv	50	60	75	Hz

Note : DE mode only

CONFIDENTIAL

AUO Confidential For AUO Internal Use Only / 2009/11/18

6.4.2 Timing Diagram

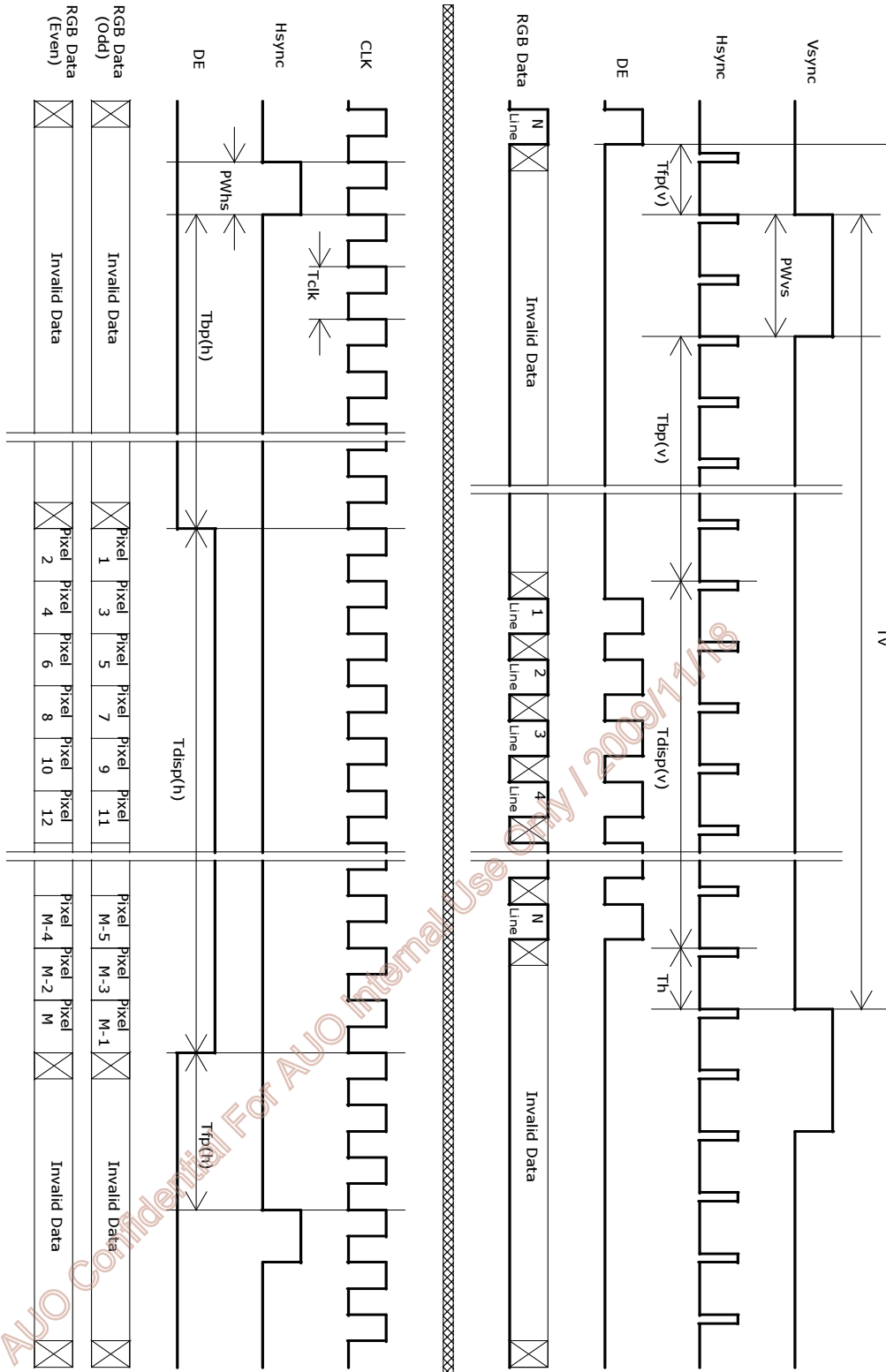

CONFIDENTIAL

6.5 Power ON/OFF Sequence

VDD power and lamp on/off sequence is as follows. Interface signals are also shown in the chart. Signals from any system shall be Hi-Z state or low level when VDD is off.

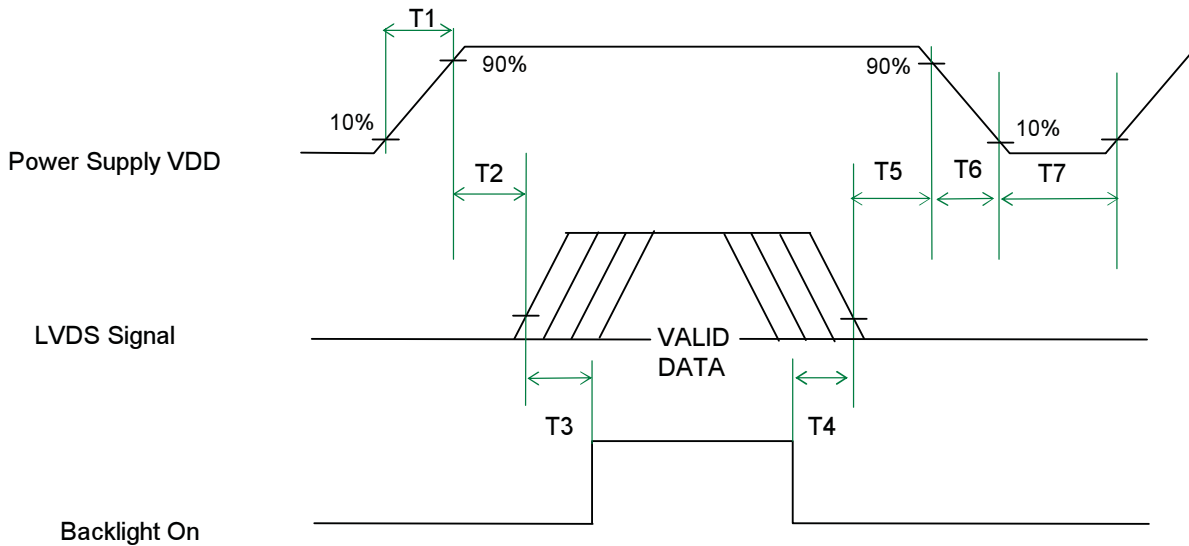

Power Sequence Timing

Parameter	Value			Unit
	Min.	Typ.	Max.	
T1	0.5	-	10	[ms]
T2	0	40	50	[ms]
T3	300	-	-	[ms]
T4	300	-	-	[ms]
T5	0.5	16	50	[ms]
T6		-	-	[ms]
T7	1000	-	-	[ms]

CONFIDENTIAL

AUO Confidential For AUO Internal Use Only / 2009/11/18



7. Connector & Pin Assignment

Physical interface is described as for the connector on module. These connectors are capable of accommodating the following signals and will be following components.

7.1 TFT LCD Module

7.1.1 Connector

Connector Name / Designation	Interface Connector / Interface card
Manufacturer	JAE / STM
Type Part Number	FI-XB30SSL-HF15 / MSBKT2407P30HB
Mating Housing Part Number	FI-X30HL

7.1.2 Pin Assignment

Pin#	Signal Name	Pin#	Signal Name
1	RxOIN0-	2	RxOIN0+
3	RxOIN1-	4	RxOIN1+
5	RxOIN2-	6	RxOIN2+
7	VSS	8	RxOCLKIN-
9	RxOCLKIN+	10	RxOIN3-
11	RxOIN3+	12	RxEIN0-
13	RxEIN0+	14	VSS
15	RxEIN1-	16	RxEIN1+
17	VSS	18	RxEIN2-
19	RxEIN2+	20	RxECLKIN-
21	RxECLKIN+	22	RxEIN3-
23	RxEIN3+	24	VSS
25	VSS	26	NC
27	VSS	28	VCC
29	VCC	30	VCC

CONFIDENTIAL

AUO Confidential For AUO Internal Use Only (20140717)



7.2 Backlight Unit

Physical interface is described as for the connector on module. These connectors are capable of accommodating the following signals and will be following components.

Connector Name / Designation	Lamp Connector / Backlight lamp
Manufacturer	CVILUX / YEONHO
Type Part Number	CP0502SL090/ 35001 HS-02L
Mating Type Part Number	CP0502P1ML0/ 35001 WR-02L

7.2.1 Signal for Lamp connector

	Connector No.	Pin No.	Input	Color	Function
Upper	CN1	1	Hot1	Pink	High Voltage
		2	Cold1	White	Low Voltage
	CN2	1	Hot2	blue	High Voltage
		2	Cold2	black	Low Voltage

	Connector No.	Pin No.	Input	Color	Function
Lower	CN3	1	Hot1	Pink	High Voltage
		2	Cold1	White	Low Voltage
	CN4	1	Hot2	blue	High Voltage
		2	Cold2	black	Low Voltage

CONFIDENTIAL

AUO Confidential For AUO Internal Use Only / 2009/11/18



8. Reliability Test

Environment test conditions are listed as following table.

Items	Required Condition	Note
Temperature Humidity Bias (THB)	Ta= 50□, 80%RH, 300hours	
High Temperature Operation (HTO)	Ta= 50□, 50%RH, 300hours	
Low Temperature Operation (LTO)	Ta= 0□, 300hours	
High Temperature Storage (HTS)	Ta= 60□, 300hours	
Low Temperature Storage (LTS)	Ta= -20□, 300hours	
Vibration Test (Non-operation)	Acceleration: 1.5 G Wave: Random Frequency: 10 - 200 - 10 Hz Sweep: 30 Minutes each Axis (X, Y, Z)	
Shock Test (Non-operation)	Acceleration: 50 G Wave: Half-sine Active Time: 20 ms Direction: ±X, ±Y, ±Z (one time for each Axis)	
Drop Test	Height: 60 cm, package test	
Thermal Shock Test (TST)	-20□/30min, 60□/30min, 100 cycles	1
On/Off Test	On/10sec, Off/10sec, 30,000 cycles	
ESD (ElectroStatic Discharge)	Contact Discharge: ± 8KV, 150pF(330Ω) 1sec, 9 points, 25 times/ point.	2
	Air Discharge: ± 15KV, 150pF(330Ω) 1sec 9 points, 25 times/ point.	
Altitude Test	Operation:10,000 ft Non-Operation:30,000 ft	

Note 1: The TFT-LCD module will not sustain damage after being subjected to 100 cycles of rapid temperature change. A cycle of rapid temperature change consists of varying the temperature from -20°C to 60°C, and back again. Power is not applied during the test. After temperature cycling, the unit is placed in normal room ambient for at least 4 hours before power on.

Note 2: According to EN61000-4-2 ESD class B: Some performance degradation allowed. No data lost. Self-recoverable. No hardware failures.

CONFIDENTIAL



9. Shipping Label

The label is on the panel as shown below:



Note 1: For Pb Free products, AUO will add  for identification.

Note 2: For RoHS compatible products, AUO will add  for identification.

Note 3: For China RoHS compatible products, AUO will add  for identification.

Note 4: The Green Mark will be presented only when the green documents have been ready by AUO Internal Green Team.

CONFIDENTIAL

AUO Confidential For AUO Internal Use Only / 2009/11/18



Product Specification

G190EG01 V0

AU OPTRONICS CORPORATION

10. Mechanical Characteristic

- NOTE:
1. PRELIMINARY DRAWING FOR REFERENCE ONLY.
 2. THE DIMENSION EXCLUDES DEFORMATION.
 3. MODULE THICKNESS SHOULD BE 18.5mm TYP.
 4. UNSPECIFIED TOLERANCE MUST FOLLOW TOLERANCE TABLE.
 5. LAMP CABLE CONNECTOR TO BE REVIXX CP0502SL090 OR COMPATIBLE.
 6. DIMENSION TO BE TAKEN FROM CENTER OF LAMP CABLE CONNECTOR.
 7. USER HOLE SCREW THROUGH 4.0mm MAX.
 8. USER HOLE SCREW PENETRATION 4.0mm MAX.
 9. DIMENSION TOLERANCE 10-61 (≤ 1.0) 10-74 (≤ 1.0)
 10. CABLE LENGTH
 11. 3.0 SCREW LEN

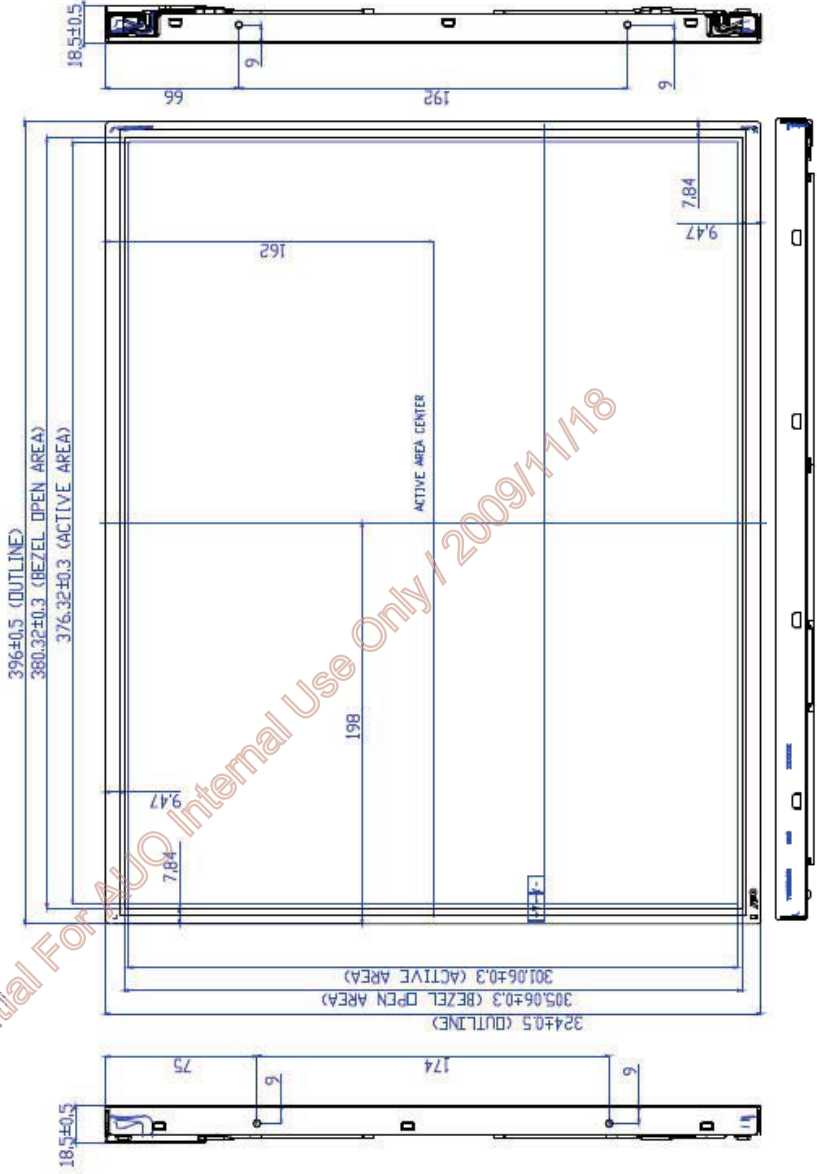



Product Specification

G190EG01 V0

AU OPTRONICS CORPORATION

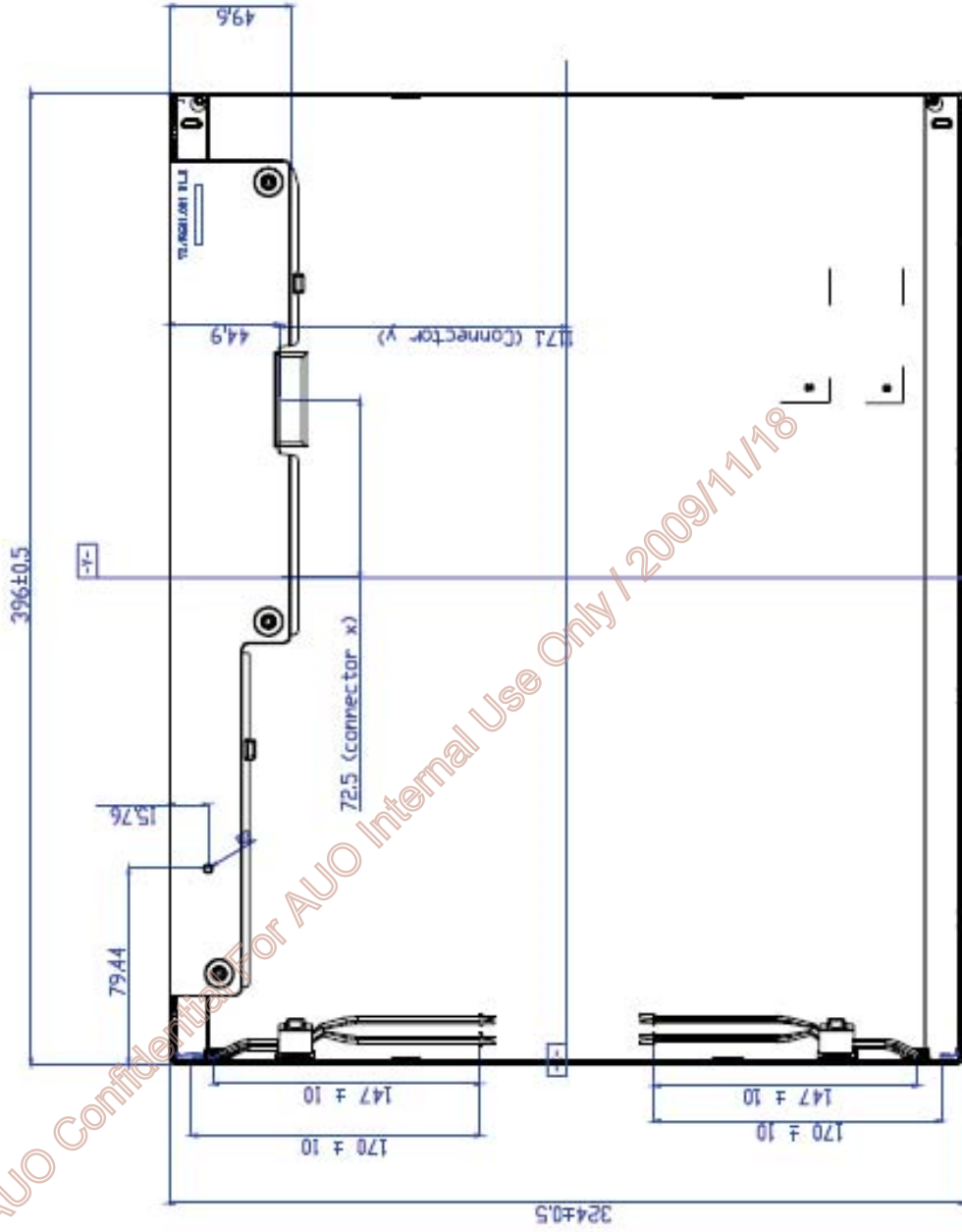

AUO Confidential for AUO Internal Use Only | 2009/11/18



US Micro Products

Electronic Products for the OEM

Los Angeles • Austin • New York • Orlando • Shenzhen

(800) 741-7755

www.usmicroproducts.com

Displays

US Micro Products is an industrial distributor specializing in engineered display solutions. We dedicate ourselves to providing the best in displays for the medical, industrial, gaming, automotive, aerospace, military, and consumer markets.

OLEDs



TFT Displays



Open Frame Monitors



Passive LCDs



Multitouch



As a customer, you benefit from our expert knowledge, support and service which allow quick selection and design-in of the best display for your application. On hand stock and demo boards facilitate quick access and evaluation to get you going fast. Our technical sales staff and experienced design engineers provide answers to your questions as well as engineered solutions to solve your display needs.

Peripheral Devices

Our full line of peripheral devices includes keyboards, trackballs, and printers. These rugged industrial products are designed to meet your demanding requirements and are available as both standard and custom solutions.

Keyboards



Trackballs



Aerospace Trackballs



Joysticks



Printers

