



US Micro Products

ENGINEERED DISPLAY SOLUTIONS

PRODUCT SPECIFICATION

MANUFACTURED BY

INNOLUX

INNOLUX CORPORATION

PART NUMBER

USMP-G025370Y1-T01

7.0" IAV WVGA TFT LCD with 800x480 resolution & CCFL Backlight, a-50-pin-and-1ch TTL interface, 262.144 (6 bits) Full Color

ISSUE DATE	APPROVED BY	CHECKED BY	PREPARED BY
PROPRIETARY NOTE	THIS SPECIFICATION IS THE PROPERTY OF US MICRO PRODUCTS AND SHALL NOT BE REPRODUCED OR COPIED WITHOUT THE WRITTEN PERMISSION OF US MICRO PRODUCTS AND MUST BE RETURNED TO US MICRO PRODUCTS UPON ITS REQUEST.		

- CONTENTS -

REVISION HISTORY	-----	3
1. GENERAL DESCRIPTION	-----	4
1.1 OVERVIEW		
1.2 FEATURES		
1.3 APPLICATION		
1.4 GENERAL SPECIFICATIONS		
1.5 MECHANICAL SPECIFICATIONS		
2. ABSOLUTE MAXIMUM RATINGS	-----	6
2.1 ABSOLUTE RATINGS OF ENVIRONMENT		
2.2 ELECTRICAL ABSOLUTE RATINGS		
2.2.1 TFT LCD MODULE		
2.2.2 BACKLIGHT UNIT		
3. ELECTRICAL CHARACTERISTICS	-----	8
3.1 RECOMMENDED OPERATION CONDITON		
3.2 CURRENT CONSUMPTION		
3.3 BACKLIGHT UNIT		
4. BLOCK DIAGRAM	-----	11
4.1 TFT LCD MODULE		
4.2 BACKLIGHT UNIT		
5. INPUT TERMINAL PIN ASSIGNMENT	-----	12
5.1 FPC I/O PIN ASSIGNMENT		
5.2 SCANNING DIRECTION		
5.3 BACKLIGHT UNIT		
5.4 COLOR DATA INPUT ASSIGNMENT		
6. INTERFACE TIMING	-----	15
6.1 AC ELECTRICAL CHARACTERISTICS		
6.2 POWER ON/OFF SEQUENCE		
7. OPTICAL CHARACTERISTICS	-----	18
7.1 TEST CONDITIONS		
7.2 OPTICAL SPECIFICATIONS		
8. PACKAGING	-----	21
9. DEFINITION OF LABELS	-----	23
9.1 CMO MODULE LABEL		
10. PRECATIONS	-----	24
10.1 ASSEMBLY AND HANDLING PRECAUTIONS		
10.2 SAFTEY PRECAUTIONS		
11. APPLICATION NOTES	-----	25
11.1 GAMMA CIRCUIT		

CONFIDENTIAL

REVISION HISTORY

Version	Date	Section	Description
Ver 0.0	Aug 08 2006	All	G070Y1-T01 Specifications was first issued.
Ver 1.0	May 17 2007	All	G070Y1-T01 Preliminary Specifications was first issued.
Ver 2.0	Sep 18 2007	All	G070Y1-T01 Approval Specifications was first issued.

CONFIDENTIAL

1. GENERAL DESCRIPTION

1.1 OVERVIEW

G070Y1-T01 is a 7inch TFT Liquid Crystal Display module with a CCFL Backlight unit and a-50-pin-and-1ch-TTL interface. This module supports 800 (R.G.B)x 480 WVGA mode which main application is the Automotive Monitor and Industrial field.

1.2 FEATURES

- Wide viewing angle.
- Fast response time
- WVGA (800 x 480 pixels) resolution
- Wide operating temperature
- Reversible - scan function

1.3 APPLICATION

- Automotive Monitor
- Factory Application

1.4 GENERAL SPECIFICATIONS

Item	Specification	Unit	Note
Diagonal Size	177.7 (7 Inch)	mm	
Active Area	152.4x91.44	mm	(1)
Bezel Opening Area	155x94.04	mm	
Driver Element	a-si TFT active matrix	-	
Pixel Number	800xR.G.B.x480	pixel	-
Pixel Pitch	0.1905x0.1905	mm	-
Pixel Arrangement	RGB vertical stripe	-	(2)
Display Colors	262.144 (6 bits)	color	-
Display Mode	Normal White	-	-
Surface Treatment	Hard Coating (3H), AG (Haze 25 %)	-	-
Weight	170(Typ)	g	

Note (1) Please refer to the attached drawings for more information of front and back outline dimensions.

Note (2)

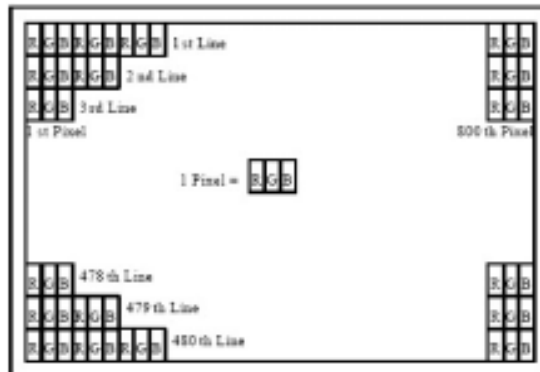

CONFIDENTIAL

1.5 MECHANICAL SPECIFICATIONS

Item		Min.	Typ.	Max.	Unit	Note
Module Size	Horizontal(H)	164.7	165	165.3	mm	(1)
	Vertical(V)	103.7	104	104.3	mm	
	Depth(D)	-	5.5	5.8	mm	

Note (1) Please refer to the attached drawings for more information of front and back outline dimensions.

CONFIDENTIAL

2. ABSOLUTE MAXIMUM RATINGS

2.1 ABSOLUTE RATINGS OF ENVIRONMENT

No.	Test Item	Test Condition	Note
1	High Temperature Storage	90°C, 240 hours	(1) (2)
2	Low Temperature Storage	-40°C, 240 hours	
3	Heat Shock Operating	{{(-40°C, 0.5 hour) (85°C, 0.5 hour)}, 100 cycles	
4	High Temperature Operating	85°C, 240 hours	
5	Low Temperature Operating	-30°C, 240 hours	
6	High Temperature & High Humidity Operating	60°C, 90%RH, 240hours	
8	Shock (Non-Operating)	100G, 6ms, +/-XYZ 3 times	(3)(5)
9	Vibration (Non-Operating)	3G, 10 to 200 Hz, sine wave	(4)(5)

Note (1) There should be no condensation on the surface of panel during test.

Note (2) The temperature of panel display surface area should be 90°C Max.

Note (3) 6ms, half sine wave, 3 times for +/-X, +/-Y, and +/-Z.

Note (4) 3 directions: X, Y and Z axes, 60min per each direction; 6 cycles; sweep time = 5 minutes; peak acceleration = 3G; frequency = 10 to 200 Hz; sine wave.

Note (5) At testing Vibration and Shock, the fixture in holding the module has to be hard and rigid enough so that the module would not be twisted or bent by the fixture

Note (6) In the standard conditions, there is no function failure issue occurred. All the cosmetic specification is judged before the reliability test

Note (7) During module operating test, the lamp current is 5.5 mA

CONFIDENTIAL

2.2 ELECTRICAL ABSOLUTE RATINGS

2.2.1 TFT LCD MODULE

Parameter	Symbol	Value			Unit	Note
		Min.	Typ.	Max.		
Power Supply Voltage	Vcc	-0.3	-	5	V	-
	AVDD	-0.5	-	13.5	V	-
	VGH	-0.3	-	42	V	-
	VGL	VGH-42	-	0.3	V	-
Input Signal Voltage	Vi	-0.3	-	Vcc+0.3	V	-
	V1~V5	0.4AVDD	-	AVDD+0.3	V	-
	V6~V10	-0.3	-	0.6AVDD	V	-
	VCOM	-	4.58	-	V	-

2.2.2 BACKLIGHT UNIT

Item	Symbol	Value		Unit	Note
		Min.	Max.		
Lamp Voltage	V_L	-	2.5K	V_{RMS}	(1), (2), $I_L = (5.5)mA$
Lamp Current	I_L	3.0	8.0	mA_{RMS}	(1), (2)
Lamp Frequency	F_L	40	80	KHz	

Note (1) Permanent damage to the device may occur if maximum values are exceeded. Function operation should be restricted to the conditions described under Normal Operating Conditions.

Note (2) Specified values are for lamp (Refer to 3.2 for further I_L information).

CONFIDENTIAL

3. ELECTRICAL CHARACTERISTIC

3.1 Recommended Operation condition (GND = AVSS = 0V)

Ta = 25 ± 2 °C

Parameter	Symbol	Value			Unit	Note
		Min.	Typ.	Max.		
Power Supply Voltage	Vcc	3.0	3.3	3.6	V	
	AVDD	11.43	11.6	11.78	V	
	VGH	17.5	18	18.5	V	
	VGL	-7.5	-7	-6.5	V	
Input Signal Voltage	V1~V5	0.4AVDD	-	AVDD-0.1	V	(1)
	V6~V10	0.1	-	0.6AVDD	V	(1)
	VCOM	-	4.584	-	V	
Digital Input Voltage	High Level	VIH	0.7Vcc	-	Vcc	V
	Low Level	VIL	0	-	0.3Vcc	V

Note : (1) Please refer to application notes

3.2 Current Consumption (GND = AVSS =0V)

Parameter	Symbol	Value			Unit	Note
		Min.	Typ.	Max.		
Supply Current for Source/Gate Driver (Digital)	I _{CC}	-	2.78	3.0	mA	(1)
Supply Current for Source Driver (Analog)	I _{DD}	-	24.8	27.0	mA	(1)
Supply Current for Gate Driver (High Level)	I _{GG}	-	0.16	0.2	mA	(1)
Supply Current for Gate Driver (Low Level)	I _{EE}	-	0.16	0.2	mA	(1)

Note: (1) The specified power supply current is under the conditions at Vcc = 3.3 V, Ta = 25 ± 2 °C, f_v = 60 Hz, whereas a power dissipation check pattern below is displayed.

Black Pattern

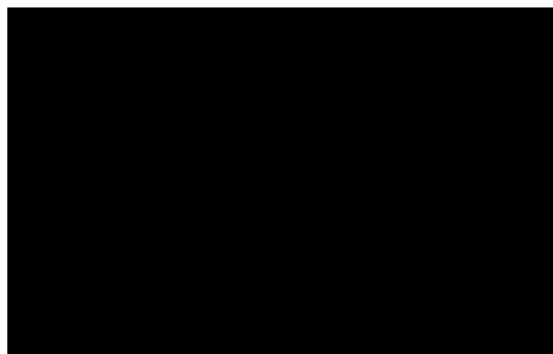

Active Area

3.3 BACKLIGHT UNIT

Ta = 25 ± 2 °C

Parameter	Symbol	Value			Unit	Note
		Min.	Typ.	Max.		
Lamp Input Voltage	V _L	740	630	550	V _{RMS}	(1), I _L = (5.5) mA
Lamp Current	I _L	3.0	5.5	8.0	mA _{RMS}	(1)
Lamp Turn On Voltage	V _S	-	-	970 (25 °C)	V _{RMS}	(2)
		-	-	1260 (0 °C)	V _{RMS}	(2)
		-	-	1460 (-35°C)	V _{RMS}	(2)
Operating Frequency	F _L	40	-	80	KHZ	(3)
Lamp Life Time	L _{BL}	35000	-	-	Hrs	(5)
Power Consumption	P _L	-	3.46	-	W	(4), I _L = (5.5) mA

Note (1) I_L means the lamp current of one lamp.

Note (2) The voltage that must be larger than V_S should be applied to the lamp for more than 1 second after startup. Otherwise the lamp may not be turned on.

Note (3) The lamp frequency may produce interference with horizontal synchronous frequency from the display, and this may cause line flow on the display. In order to avoid interference, the lamp frequency should be detached from the horizontal synchronous frequency and its harmonics as far as possible.

Note (4) P_L = I_L × V_L

Note (5) The lifetime of lamp can be defined as the time in which it continues to operate under the condition Ta = 25 ± 2 °C and I_L = (5.5) mA_{RMS} until one of the following events occurs:

- (a) When the brightness becomes or lower than 50% of its original value.
- (b) When the effective ignition length becomes or lower than 80% of its original value. (Effective ignition length is defined as an area that has less than 70% brightness compared to the brightness in the center point.)

Note (6) The waveform of the voltage output of inverter must be area-symmetric and the design of the inverter must have specifications for the modularized lamp. The performance of the Backlight, such as lifetime or brightness, is greatly influenced by the characteristics of the DC-AC inverter for the lamp. All the parameters of an inverter should be carefully designed to avoid producing too much current leakage from high voltage output of the inverter. When designing or ordering the inverter please make sure that a poor lighting caused by the mismatch of the Backlight and the inverter (miss-lighting, flicker, etc.) never occurs. If the above situation is confirmed, the module should be operated in the same manners when it is installed in your instrument.

The output of the inverter must have symmetrical (negative and positive) voltage waveform and symmetrical current waveform.(Unsymmetrical ratio is less than 10%) Please do not use the inverter which has unsymmetrical voltage and unsymmetrical current and spike wave. Lamp frequency may produce interface with horizontal synchronous frequency and as a result this may cause beat on the display. Therefore lamp frequency shall be as away possible from the horizontal synchronous frequency and from its harmonics in order to prevent interference.

Requirements for a system inverter design, which is intended to have a better display performance, a better power efficiency and a more reliable lamp. It shall help increase the lamp lifetime and reduce its

leakage current.

- a. The asymmetry rate of the inverter waveform should be 10% below;
- b. The distortion rate of the waveform should be within $\sqrt{2} \pm 10\%$;
- c. The ideal sine wave form shall be symmetric in positive and negative polarities.

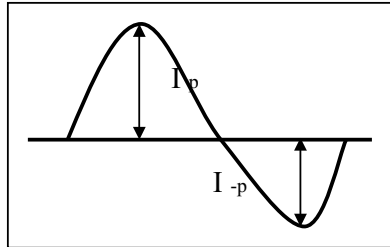

* Asymmetry rate:

$$\frac{|I_p - I_{-p}|}{I_{rms}} * 100\%$$

* Distortion rate

$$I_p \text{ (or } I_{-p}) / I_{rms}$$

CONFIDENTIAL

4. BLOCK DIAGRAM
4.1 TFT LCD MODULE

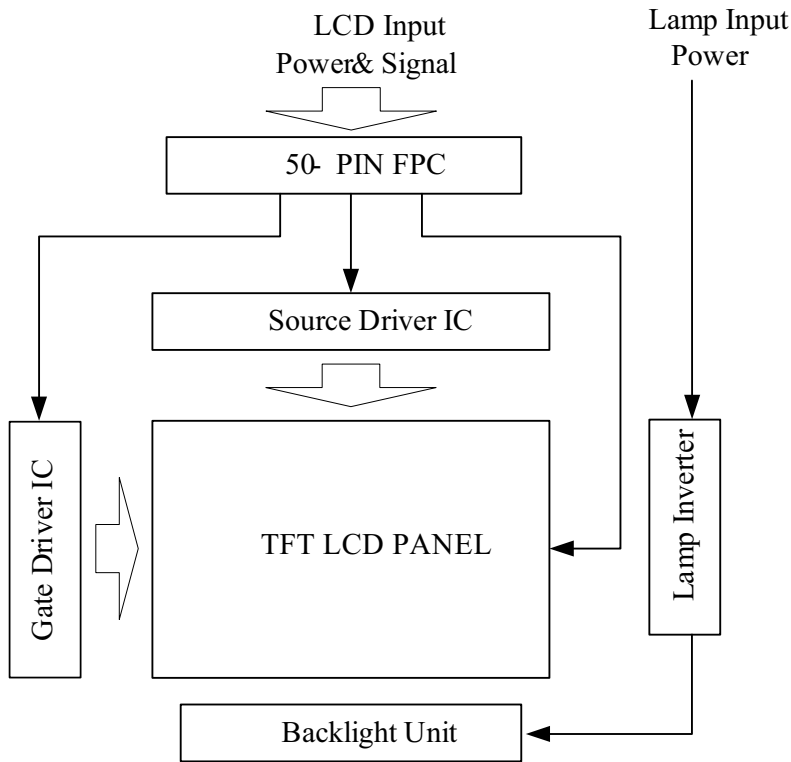

4.2 BACKLIGHT UNIT

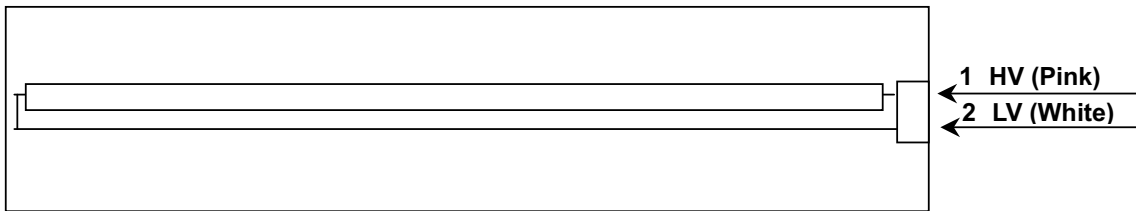

CONFIDENTIAL

5. INPUT TERMINAL PIN ASSIGNMENT

5.1 FPC I/O Pin Assignment

Pin	Name	I/O	Description
1	GND	I	Ground
2	Vcc	I	Digital Voltage
3	VGL	I	TFT Low Voltage
4	VGH	I	TFT High Voltage
5	STVD	I/O	Start Pulse Signal Input / Output (Vertical)
6	STVU	I/O	Start Pulse Signal Input / Output (Vertical)
7	CKV	I	Gate Driver Shift Clock Input
8	U/D	I	Up / Down Scan Selection
9	OE	I	Gate Driver Output Enable Control
10	VCOM	I	VCOM Voltage
11	DIO1	I/O	Start Pulse Signal Input / Output (Horizontal)
12	AVDD	I	Source Driver Analog Voltage
13	GND	I	Ground
14	GND	I	Ground
15	Vcc	I	Digital Voltage
16	EDGSL	I	Source Driver Clock Edge Select Input
17	CLK	I	Source Driver Shift Clock Input
18	SHL	I	Source Driver Shift Direction Control Input
19	R0	I	Red Data
20	R1	I	Red Data
21	R2	I	Red Data
22	R3	I	Red Data
23	R4	I	Red Data
24	R5	I	Red Data
25	G0	I	Green Data
26	G1	I	Green Data
27	G2	I	Green Data
28	G3	I	Green Data
29	G4	I	Green Data
30	G5	I	Green Data
31	V1	I	Gamma Voltage 1
32	V2	I	Gamma Voltage 2
33	V3	I	Gamma Voltage 3
34	V4	I	Gamma Voltage 4
35	V5	I	Gamma Voltage 5
36	V6	I	Gamma Voltage 6
37	V7	I	Gamma Voltage 7
38	V8	I	Gamma Voltage 8
39	V9	I	Gamma Voltage 9
40	V10	I	Gamma Voltage 10

CONFIDENTIAL

41	B0	I	Blue Data
42	B1	I	Blue Data
43	B2	I	Blue Data
44	B3	I	Blue Data
45	B4	I	Blue Data
46	B5	I	Blue Data
47	LD	I	Latching and Data Switching input
48	REV	I	Data Inversion Input
49	POL	I	Polarity Inverting Input
50	DIO2	I/O	Start Pulse Signal Input / Output (Horizontal)

Note (1) User's connector Part No: (FH12-50S-0.5 (Hiroses)) or equivalent

5.2 SCANNING DIRECTION

The following figures are seen from a front view and the arrow shows the direction of scan.

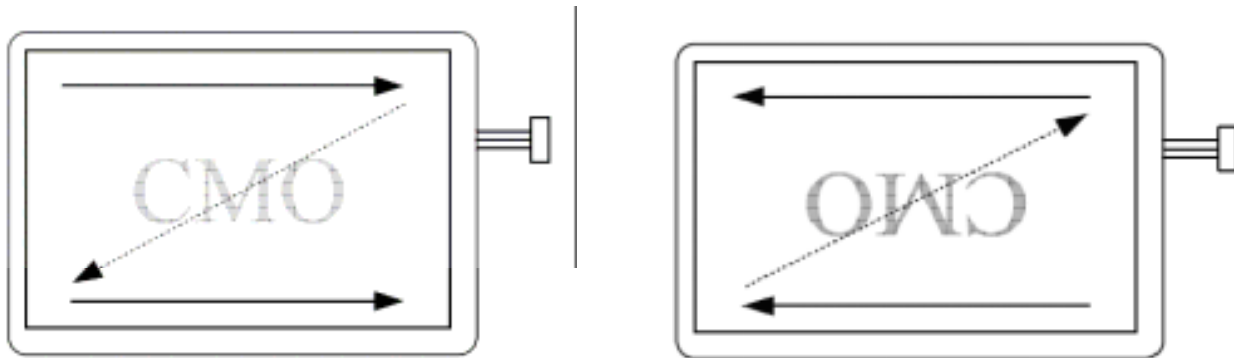

Figure1.Normal scan

Figure 2. Reverse scan

Note : (1) Normal Scan

SHL	U/D	DIO1	DIO2	STVU	STVD	Shift
1	0	Input	Output	Input	Output	Up to down Left to right

(2) Reverse Scan

SHL	U/D	DIO1	DIO2	STVU	STVD	Shift
0	1	Output	Input	Output	Input	Down to Up Right to left

5.3 BACKLIGHT UNIT

Pin	Symbol	Description	Remark
1	HV1	High Voltage	Pink
2	N/A	N/A	N/A
3	LV	Low Voltage	White-

Note (1) Connector Part No.: BHR-03VS-1 (J.S.T Mfg,Co,Ltd)

5.4 COLOR DATA INPUT ASSIGNMENT

The brightness of each primary color (red, green and blue) is based on the 6-bit gray scale data input for the color. The higher the binary input, the brighter the color. The table below provides the assignment of color versus data input.

Color		Data Signal																	
		Red						Green						Blue					
		R5	R4	R3	R2	R1	R0	G5	G4	G3	G2	G1	G0	B5	B4	B3	B2	B1	B0
Basic Colors	Black	0	0	0	0	0	0	0	0	0	0	0	0	0	0	0	0	0	0
	Red	1	1	1	1	1	1	0	0	0	0	0	0	0	0	0	0	0	0
	Green	0	0	0	0	0	0	1	1	1	1	1	1	0	0	0	0	0	0
	Blue	0	0	0	0	0	0	0	0	0	0	0	0	1	1	1	1	1	1
	Cyan	0	0	0	0	0	0	1	1	1	1	1	1	1	1	1	1	1	1
	Magenta	1	1	1	1	1	1	0	0	0	0	0	0	0	1	1	1	1	1
	Yellow	1	1	1	1	1	1	1	1	1	1	1	1	0	0	0	0	0	0
	White	1	1	1	1	1	1	1	1	1	1	1	1	1	1	1	1	1	1
Gray Scale Of Red	Red(0) / Dark	0	0	0	0	0	0	0	0	0	0	0	0	0	0	0	0	0	0
	Red(1)	0	0	0	0	0	1	0	0	0	0	0	0	0	0	0	0	0	0
	Red(2)	0	0	0	0	1	0	0	0	0	0	0	0	0	0	0	0	0	0
	:	:	:	:	:	:	:	:	:	:	:	:	:	:	:	:	:	:	:
	:	:	:	:	:	:	:	:	:	:	:	:	:	:	:	:	:	:	:
	Red(61)	1	1	1	1	0	1	0	0	0	0	0	0	0	0	0	0	0	0
	Red(62)	1	1	1	1	1	0	0	0	0	0	0	0	0	0	0	0	0	0
	Red(63)	1	1	1	1	1	1	0	0	0	0	0	0	0	0	0	0	0	0
Gray Scale Of Green	Green(0) / Dark	0	0	0	0	0	0	0	0	0	0	0	0	0	0	0	0	0	0
	Green(1)	0	0	0	0	0	0	0	0	0	0	0	1	0	0	0	0	0	0
	Green(2)	0	0	0	0	0	0	0	0	0	0	1	0	0	0	0	0	0	0
	:	:	:	:	:	:	:	:	:	:	:	:	:	:	:	:	:	:	:
	:	:	:	:	:	:	:	:	:	:	:	:	:	:	:	:	:	:	:
	Green(61)	0	0	0	0	0	0	1	1	1	1	0	1	0	0	0	0	0	0
	Green(62)	0	0	0	0	0	0	1	1	1	1	1	0	0	0	0	0	0	0
	Green(63)	0	0	0	0	0	0	1	1	1	1	1	1	0	0	0	0	0	0
Gray Scale Of Blue	Blue(0) / Dark	0	0	0	0	0	0	0	0	0	0	0	0	0	0	0	0	0	0
	Blue(1)	0	0	0	0	0	0	0	0	0	0	0	0	0	0	0	0	0	1
	Blue(2)	0	0	0	0	0	0	0	0	0	0	0	0	0	0	0	0	1	0
	:	:	:	:	:	:	:	:	:	:	:	:	:	:	:	:	:	:	:
	:	:	:	:	:	:	:	:	:	:	:	:	:	:	:	:	:	:	:
	Blue(61)	0	0	0	0	0	0	0	0	0	0	0	0	1	1	1	1	0	1
	Blue(62)	0	0	0	0	0	0	0	0	0	0	0	0	1	1	1	1	1	0
	Blue(63)	0	0	0	0	0	0	0	0	0	0	0	0	1	1	1	1	1	1

Note (1) 0: Low Level Voltage, 1: High Level Voltage

CONFIDENTIAL

6. INTERFACE TIMING

6.1 AC Electrical Characteristics ($V_{CC} = 3.3V$, $AVDD = 8.4V$, $AVSS = GND = 0V$, $T_a = 25^\circ C$)

Parameter	Symbol	Value			Unit	Condition
		Min.	Typ.	Max.		
CLK frequency	Fclk	-	40	47	MHz	-
CLK Pulse width	Tcw	6	-	-	ns	-
Data setup time	Tsu	4	-	-	ns	D00~D55, REV and DIO1/2 to CLK
Data hold time	Thd	2	-	-	ns	D00~D55, REV and DIO1/2 to CLK
Propagation delay of DIO2/1	Tphi	6	10	15	ns	CL = 25pF (Output)
Time that the last data to LD	Tld	1	-	-	Tcph	-
Pulse width of LD	Twld	2	-	-	Tcph	-
Time that LD to DIO1/2	Tlds	5	-	-	Tcph	-
POL setup time	Tpsu	6	-	-	ns	POL to LD
POL hold time	Tphd	6	-	-	ns	POL to LD
Output stable time	Tst	-	-	12	us	10% or 90% target voltage, CL = 60pF, R = 2KΩ
CKV period	t _{CPV}	5	-	-	us	-
CKV pulse width	t _{CPVH} , t _{CPVL}	2.5	-	-	us	50% duty cycle
OE pulse width	t _{WOE}	1	-	-	us	-
STV setup time	t _{SU}	700	-	-	ns	-
STV hold time	t _{HD}	700	-	-	ns	-

CONFIDENTIAL

■ Timing Diagram 1

- EDGSL = "0" or open

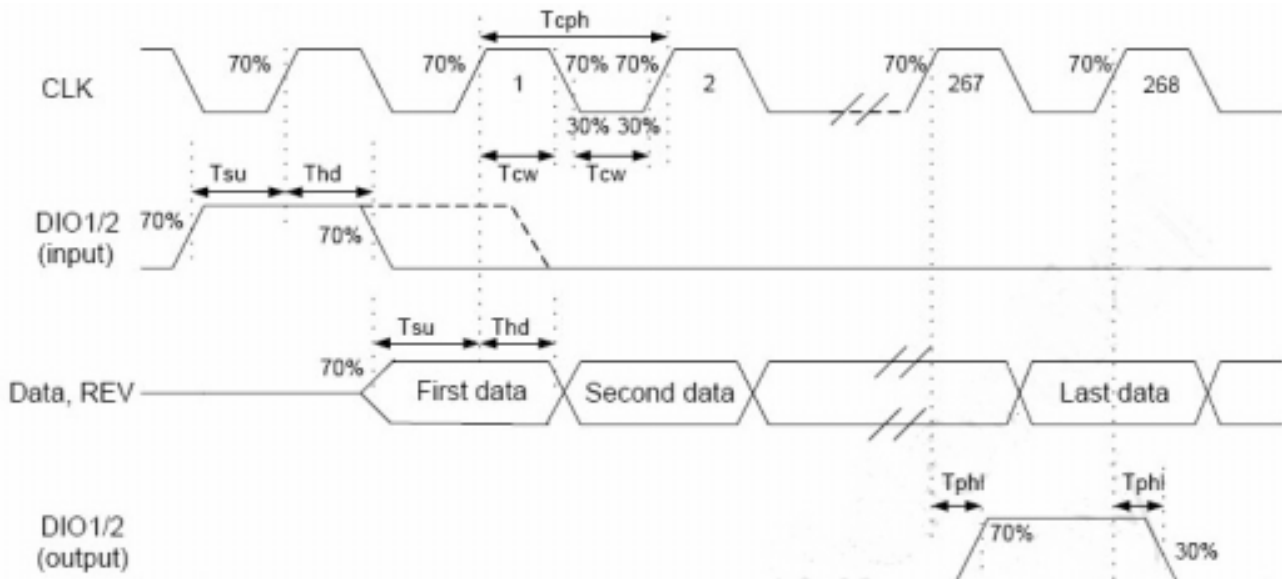

●EDGSL = "1"

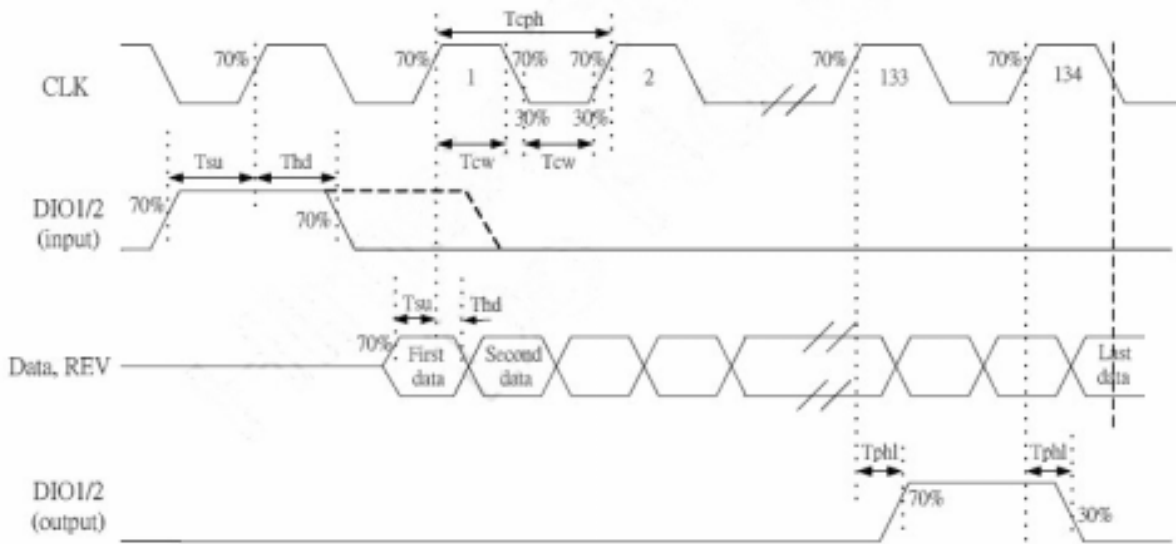

■Timing Diagram 2

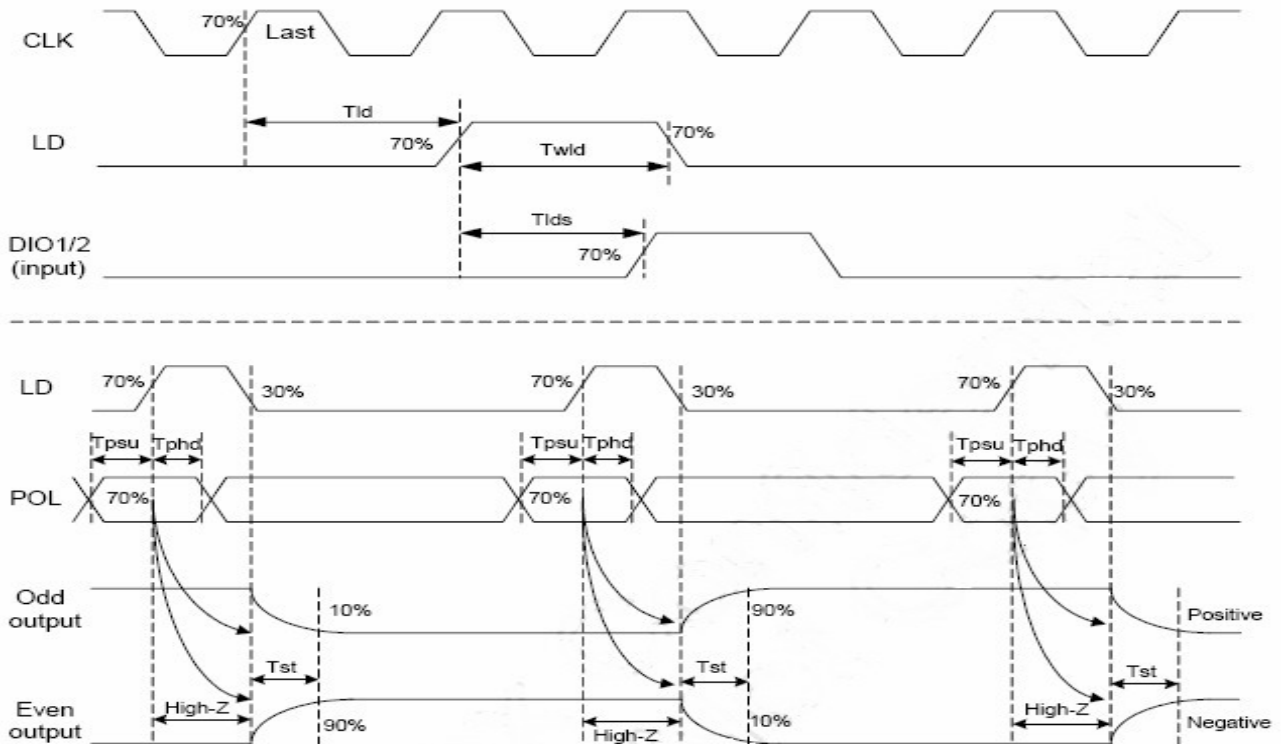

CONFIDENTIAL

■Timing Diagram 3

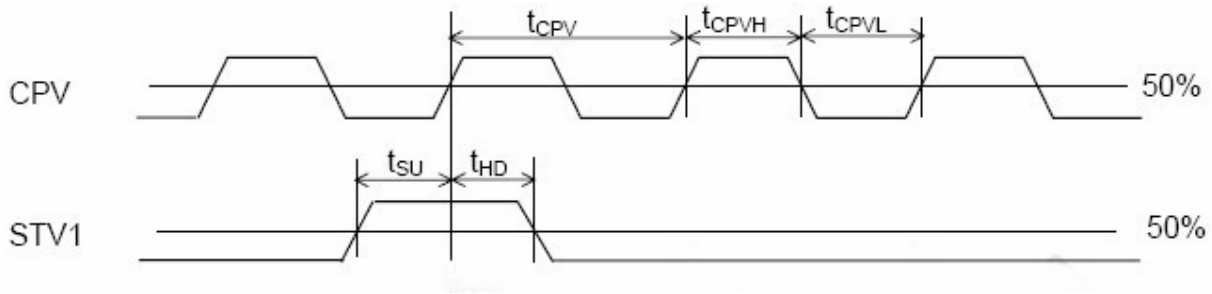

6.2 POWER ON/OFF SEQUENCE

To prevent the device from damage due to latch up, the power ON/OFF sequence shown below must be followed.

Power on sequence: $V_{CC} \rightarrow V_{GL} \rightarrow V_{GH}$

Power off sequence: $V_{GH} \rightarrow V_{GL} \rightarrow V_{CC}$

CONFIDENTIAL

7. OPTICAL CHARACTERISTICS

7.1 TEST CONDITIONS

Item	Symbol	Value	Unit
Ambient Temperature	Ta	25±2	°C
Ambient Humidity	Ha	50±10	%RH
Supply Voltage	V _{CC}	3.3	V
Input Signal	According to typical value in "3. ELECTRICAL CHARACTERISTICS"		
Lamp Current	I _L	5.5	mA _{RMS}
Inverter Operating Frequency	F _L	61	KHz
Inverter	(Sumida IV40090T/B2)		

Note (1) I_L means the lamp current of one lamp.

7.2 OPTICAL SPECIFICATIONS

The relative measurement methods of optical characteristics are shown in 7.2. The following items should be measured under the test conditions described in 7.1 and stable environment shown in Note (6).

Item	Symbol	Condition	Min.	Typ.	Max.	Unit	Note						
Color Chromaticity	Red	$\theta_x=0^\circ, \theta_y=0^\circ$ Viewing Normal Angle	Typ - 0.03	0.597	Typ + 0.03		(1), (6)						
				Ry				0.338					
	Green			Gx				0.315					
				Gy				0.535					
	Blue			Bx				0.138					
				By				0.154					
	White			Wx				0.313					
				Wy				0.329					
	Center Luminance of White			L _C					330	450	-	cd/m ²	(4), (6)
	Contrast Ratio			CR					350	500	-	-	(2), (6)
Response Time	T _R		-	5	10	Ms	(3)						
	T _F		-	11	16	Ms							
White Variation	δW		-	1.25	1.4	-	(5), (6)						
Viewing Angle	Horizontal	CR ≥ 10		60	70	-	Deg.	(1), (6)					
				60	70	-							
	Vertical			50	60	-							
				50	60	-							

CONFIDENTIAL

Note (1) Definition of Viewing Angle (θ_x, θ_y):

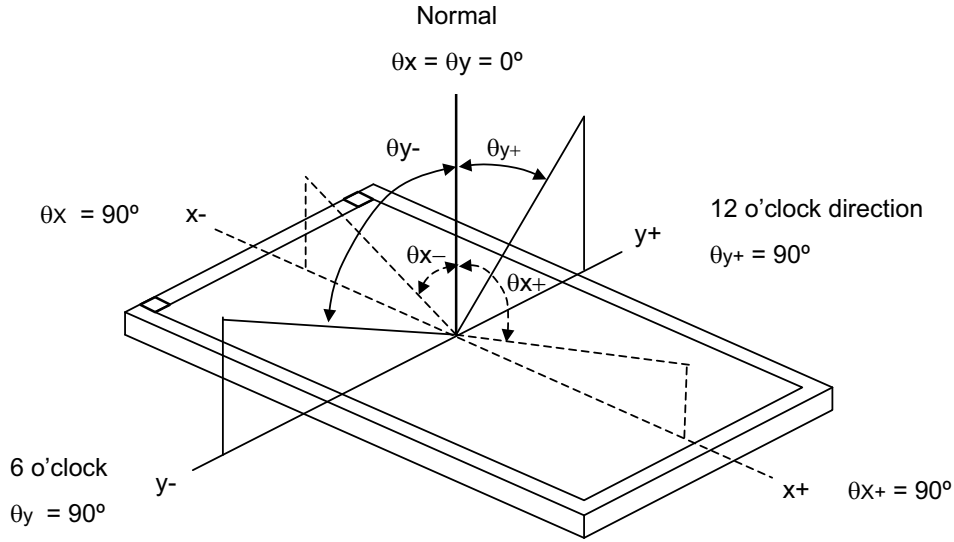

Note (2) Definition of Contrast Ratio (CR):

The contrast ratio can be calculated by the following expression.

$$\text{Contrast Ratio (CR)} = L_{63} / L_0$$

L63: Luminance of gray level 63

L 0: Luminance of gray level 0

$$\text{CR} = \text{CR} (5)$$

CR (X) is corresponding to the Contrast Ratio of the point X at Figure in Note (5).

Note (3) Definition of Response Time (T_R, T_F) and measurement method:

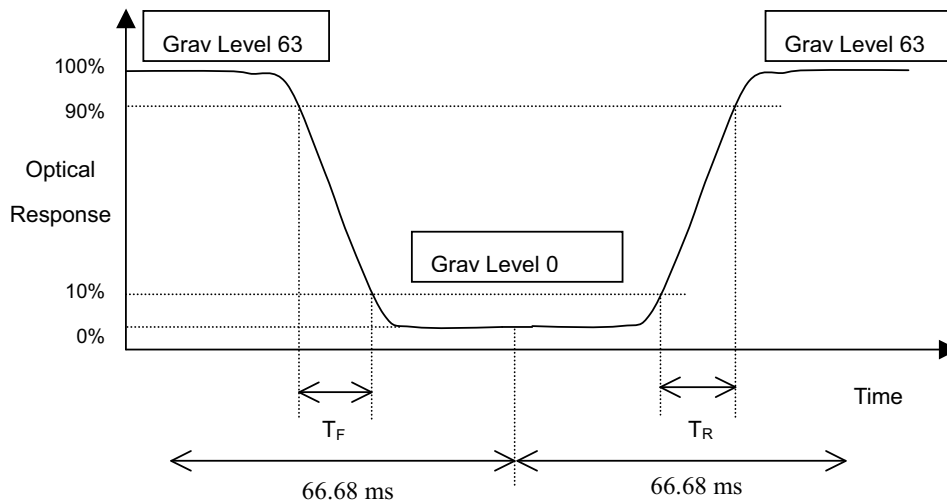

Note (4) Definition of Luminance of White (L_C):

Measure the luminance of gray level 63 at center point

$$L_C = L(5)$$

$L(x)$ is corresponding to the luminance of the point X at Figure in Note (5).

Note (5) Definition of White Variation (δW):

Measure the luminance of gray level 63 at 5 points

$$\delta W = \text{Maximum} [L(1), L(2), L(3), L(4), L(5)] / \text{Minimum} [L(1), L(2), L(3), L(4), L(5)]$$

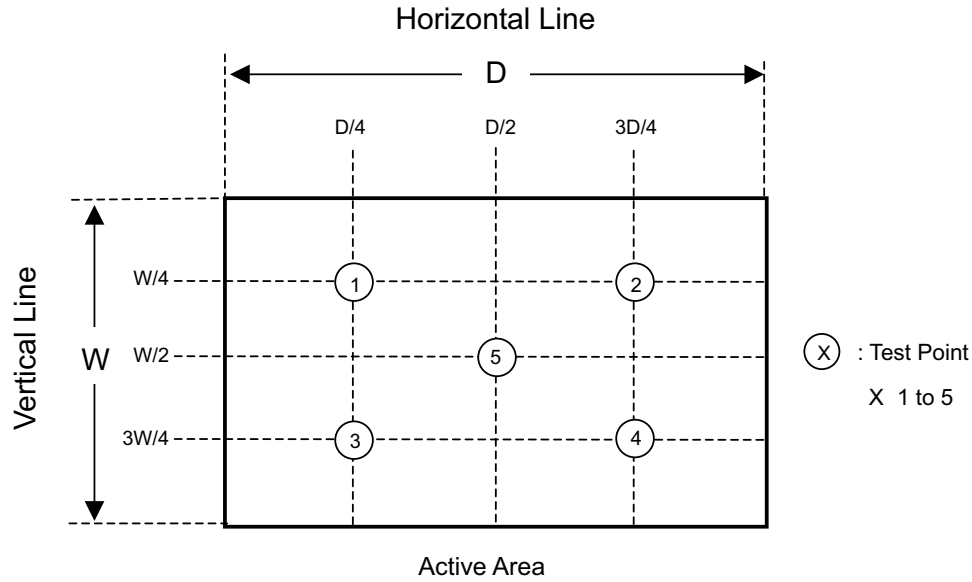

Note (6) Measurement Setup:

The LCD module should be stabilized at given temperature for 20 minutes to avoid abrupt temperature change during measuring. In order to stabilize the luminance, the measurement should be executed after lighting Backlight for 20 minutes in a windless room.

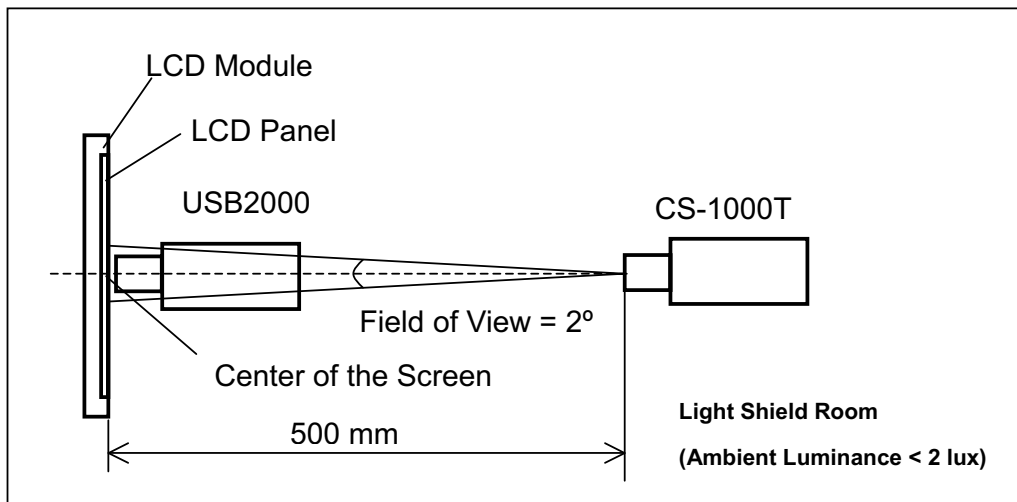

8. PACKAGING

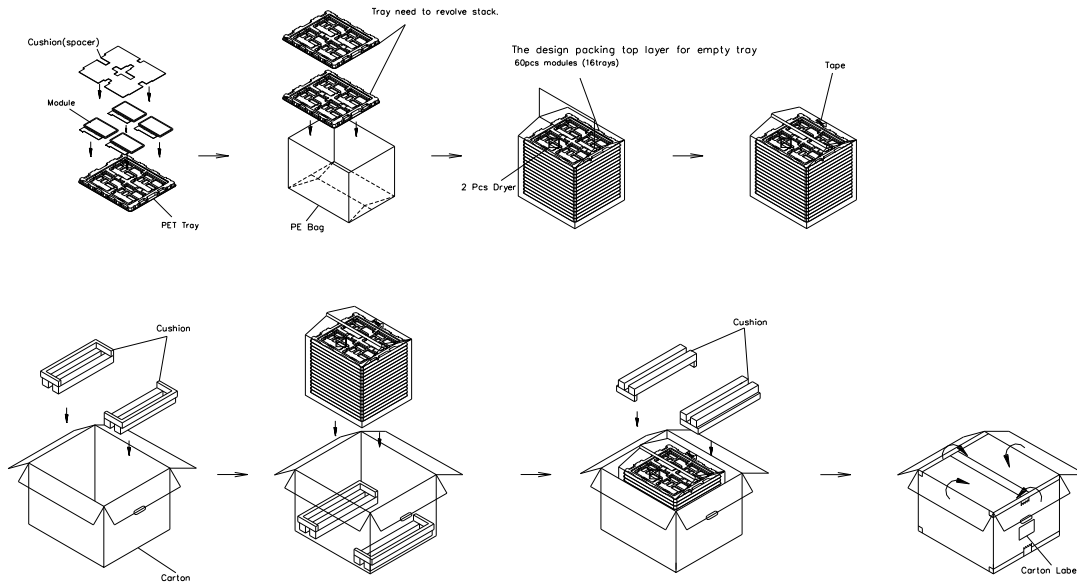

- (1) 60 LCM Modules/1 box
- (2) Carton dimensions : 545(L)x480(W)x395(H)mm
- (3) Weight : approximately 16.2 kg(60 modules per Carton).

CONFIDENTIAL

Sea and Land Transportation

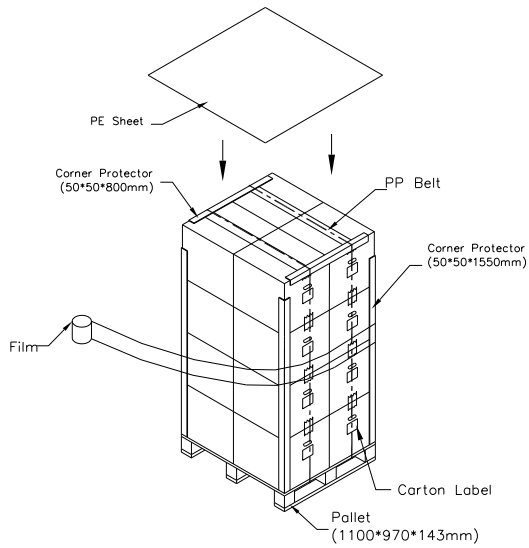

Air Transportation

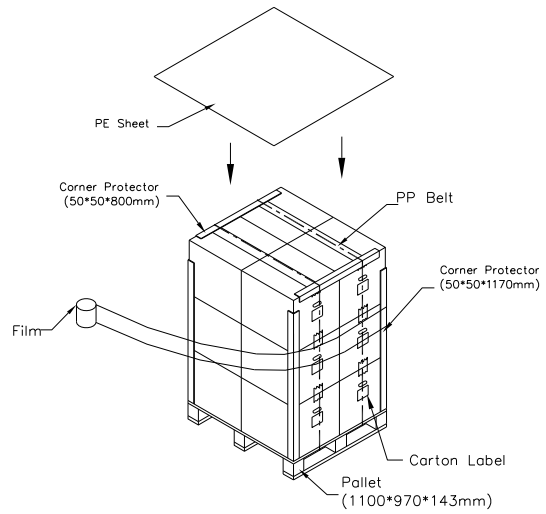

CONFIDENTIAL

9. DEFINITION OF LABELS
9.1 CMO MODULE LABEL

The barcode nameplate is pasted on each module as illustration, and its definitions are as following explanation.

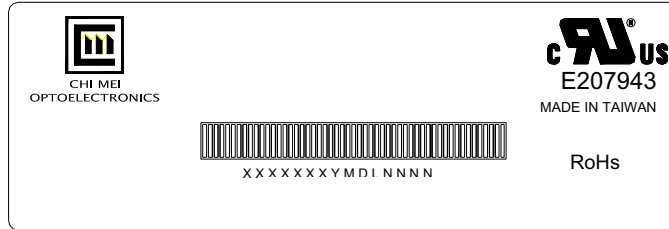

- (a) Model Name: G070Y1 - T01
- (b) Revision: Rev. XX, for example: A1, ..., C1, C2 ...etc.
- (c) Serial ID: XXXXXXYMDXNNNN

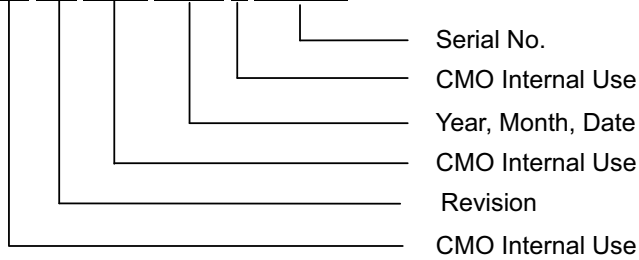

Serial ID includes the information as below:

- (a) Manufactured Date: Year: 1~9, for 2001~2009
Month: 1~9, A~C, for Jan. ~ Dec.
Day: 1~9, A~Y, for 1st to 31st, exclude I , O and U
- (b) Revision Code: cover all the change
Serial No.: Manufacturing sequence of product

CONFIDENTIAL

10. PRECAUTIONS

10.1 ASSEMBLY AND HANDLING PRECAUTIONS

- (1) Do not apply rough force such as bending or twisting to the module during assembly.
- (2) To assemble or install module into user's system can be only in clean working areas. The dust and oil may cause electrical short or worsen the polarizer.
- (3) It's not permitted to have pressure or impulse on the module because the LCD panel and Backlight will be damaged.
- (4) Always follow the correct power sequence when LCD module is connecting and operating. This can prevent damage to the CMOS LSI chips during latch-up.
- (5) Do not pull the I/F connector in or out while the module is operating.
- (6) Do not disassemble the module.
- (7) Use a soft dry cloth without chemicals for cleaning, because the surface of polarizer is very soft and easily scratched.
- (8) It is dangerous that moisture come into or contacted the LCD module, because moisture may damage LCD module when it is operating.
- (9) High temperature or humidity may reduce the performance of module. Please store LCD module within the specified storage conditions.
- (10) When ambient temperature is lower than 10°C may reduce the display quality. For example, the response time will become slowly, and the starting voltage of CCFL will be higher than room temperature.

10.2 SAFETY PRECAUTIONS

- (1) The startup voltage of Backlight is approximately 1000 Volts. It may cause electrical shock while assembling with inverter. Do not disassemble the module or insert anything into the Backlight unit.
- (2) If the liquid crystal material leaks from the panel, it should be kept away from the eyes or mouth. In case of contact with hands, skin or clothes, it has to be washed away thoroughly with soap.
- (3) After the module's end of life, it is not harmful in case of normal operation and storage.

11. APPLICATION NOTES
11.1 GAMMA CIRCUIT

AVDD	11.60
V1	11.12
V2	8.86
V3	8.41
V4	8.11
V5	7.08
V6	5.90
V7	4.00
V8	3.48
V9	2.88
V10	0.26
VCOM	4.584

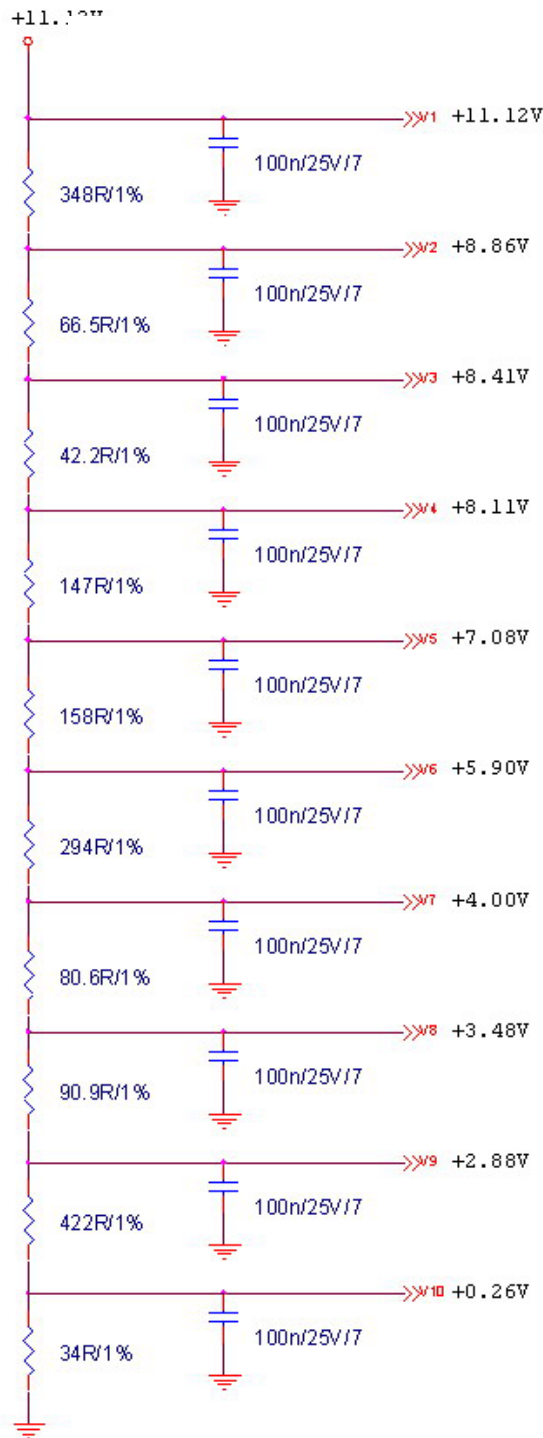

CONFIDENTIAL

165 (OUTLINE)
155 (OPENING AREA)

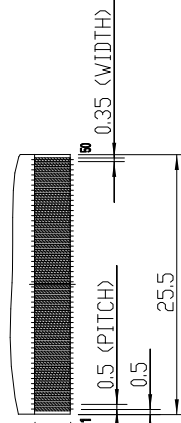
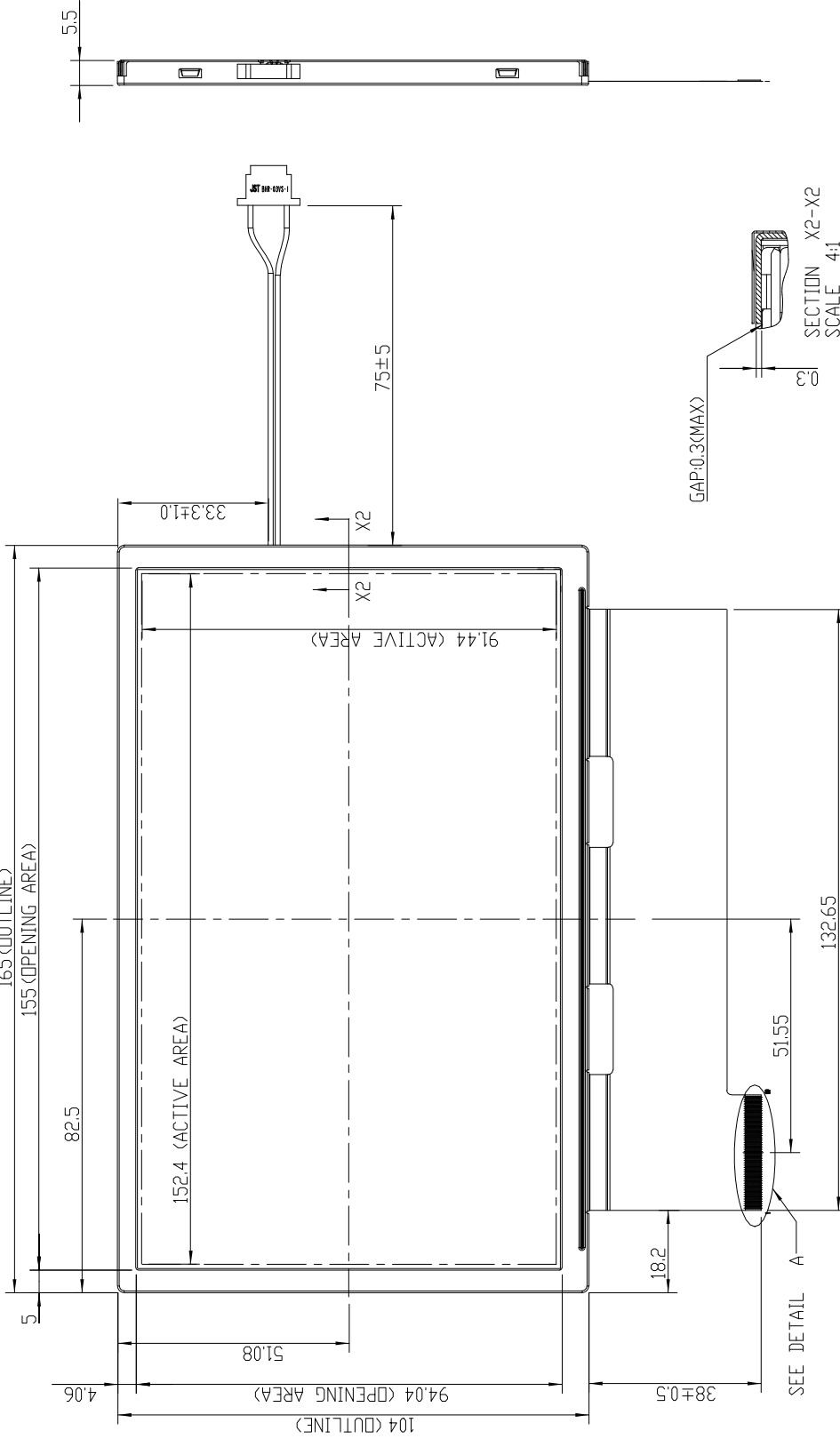

DETAIL A
SCALE 2:1

- NOTES:
1. OUTLINE TOLERANCE: ±0.3mm.
2. LAMP CONNECTOR: BHR-03V-(KJST)
3. FPC MATING CONNECTOR: FH12-50S-0.5SHK(55) (HIROSE)

TITLE	ASSY_MODULE_G070Y1-T01	Drawing No.	G070Y1/01A	2D REV. A
Approved	YULE_LIN	Part No.	TBD	3D REV. 1.3
Checked	TIGER_CHANG	Material	TBD	
Drawer	AIDEN_VAN	Date	08-Aug-2007	Sheet 1 / 2
Designer	AIDEN_VAN	Scale	1:1	Unit:mm



ALL RIGHTS RESERVED. COPYING FORBIDDEN.

Mark	Description	Date	Changed_By	Approved_By	ECN No.	Remark

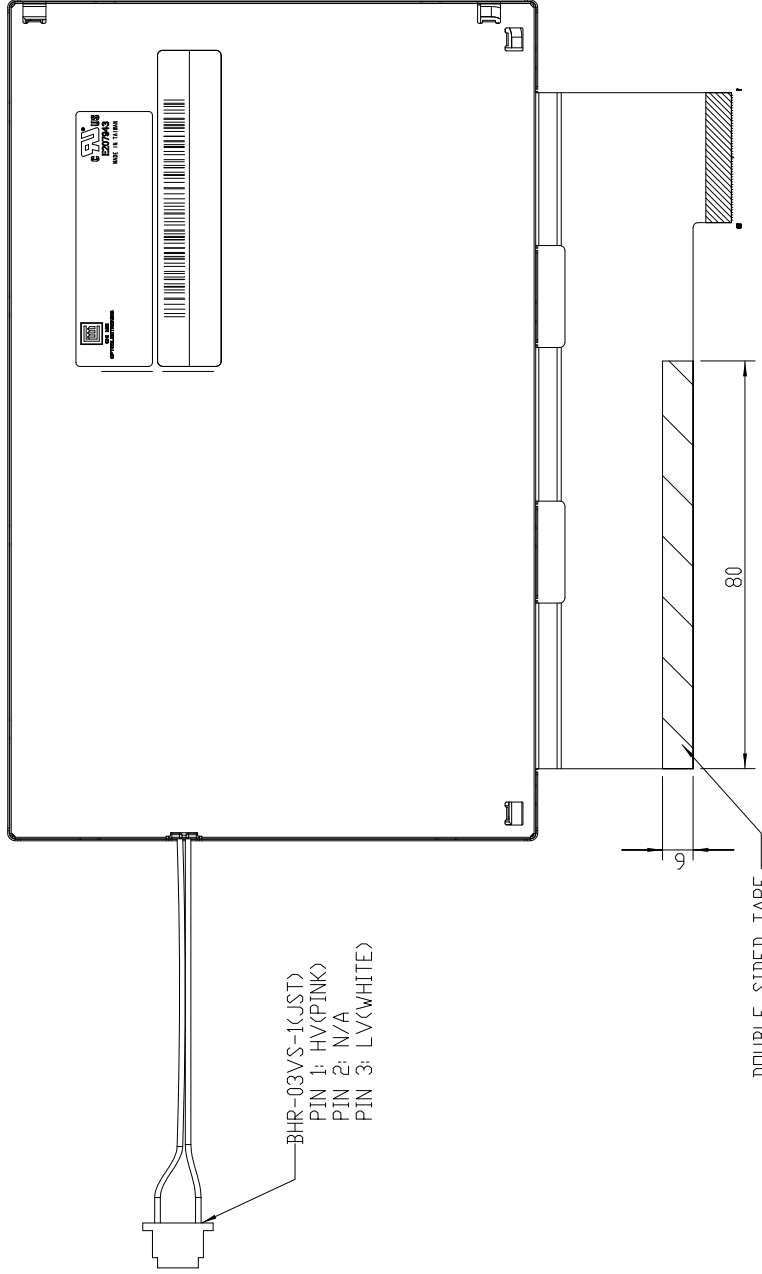

DOUBLE SIDED TAPE

TITLE	ASSY_MODULE_G070Y1-T01	2D REV. A
Approved	YULE_LIN	Drawing No. G07014101A
Checked	TIGER_CHANG	Part No. TBD
Drawer	AIDEN_WAN	Material TBD
Designer	AIDEN_WAN	Date 08-Aug-2007
		Scale 1:1
		Sheet 2 / 2
		Unit:mm



ALL RIGHTS RESERVED. COPYING FORBIDDEN.

Mark	Description	Date	Changed_By	Approved_By	ECN No.	Remark

DISPLAYS

Engineered to fit your application, US Micro Products offers a wide range of standard and custom LCD solutions. We dedicate ourselves to providing the best in displays for the medical, industrial, gaming, automotive, aerospace, military and consumer markets.

OLEDs



TFTs



Open Frame Monitors



Passive LCDs



Multitouch

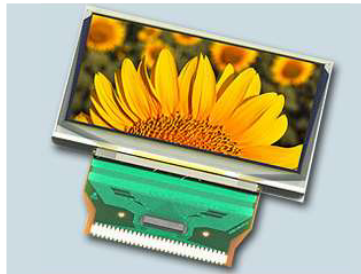

Touch Screen



As our customer, you receive expert knowledge, support and service. Our technical sales staff and experienced design engineers provide answers to your questions and engineered solutions to meet your displays needs.

PERIPHERAL DEVICES

Our full line of peripheral devices includes keyboards, trackballs, and printers. These rugged industrial products are designed to meet your demanding requirements and are available as both standard and custom solutions.

Keyboards



Trackballs



Aerospace Trackballs



Printers

