



US Micro Products
Electronic Products for the OEM

AMOLED PRODUCT SPECIFICATION

Manufactured By



奇晶光電股份有限公司
CHI MEI EL CORPORATION

PART NUMBER:	USMP-A34480TP
DESCRIPTION:	3.4", 480 RGB x 272, 16M Full Color, HX5116 IC, COG Assembly, Touch Panel

ISSUE DATE	APPROVED BY (Customer Use Only)	CHECKED BY	PREPARED BY
PROPRIETARY NOTE:	THIS SPECIFICATION IS THE PROPERTY OF US MICRO PRODUCTS AND SHALL NOT BE REPRODUCED OR COPIED WITHOUT THE WRITTEN PERMISSION OF US MICRO PRODUCTS AND MUST BE RETURNED TO US MICRO PRODUCTS UPON ITS REQUEST.		



Reversion History

Version	Date	Page	Description
Ver.1.0	2008/02/29	All	Tentative specification was first issued
Ver.1.1	2008/03/19	18	Change External Dimension
Ver.1.2	2008/04/08	10,11,12	Modify Initial Register Setting
		14	Add System Diagram
Ver.1.3	2008/04/15	10	Modify Electro-Optical Characteristic
Ver.1.4	2008/05/28	5	Modify DC Characteristic
		10,11,12	Modify Initial Register Setting
		15	Modify Pin Assignment
Ver.1.5	2008/07/08	10,11,12	Modify Electro-Optical Characteristic & Initial Register Setting
Ver.1.6	2008/09/25	10,11,12	Modify Initial Register Setting
		19	Add Reliability Test
		3	Add Weight of Mechanical Data
Ver.1.7	2008/10/02	20	Add Package Drawing
Ver.1.8	2008/11/21	10	Modify Life Time
Ver.1.9	2008/12/01	10	Modify Electro-Optical Characteristic
Ver.2.0	2009/5/20	10,11,12	Modify Initial Register Setting(Gamma:6)
Ver.2.1	2009/6/17	10,11,12	Modify Initial Register Setting(Gamma:7) and Electro-Optical Characteristic

CONFIDENTIAL



1. Purpose:

This documentation defines general product specification for OLED module supplied by CMEL. The information described in this technical specification is tentative. Please Contact CMEL’s representative while your product is modified.

2. General Description:

- Driving Mode: Active Matrix
- Color Mode: Full Color (16M color)
- Driver IC: HX5116, COG Assembly
- Interface:
8bit serial RGB and 24bit parallel RGB interface
- Application: Portable DVD, PMP, GPS, Photo Frame etc.

3. Mechanical Data:

No.	Items	Specification	Unit
1	Diagonal Size	3.4	Inch
2	Resolution	480 x RGB x 272	
3	Pixel Pitch	H: 156 V: 156	um
4	Active Area	74.88 x 42.43	mm
5	Outline Area	82.8 x 54.3	mm
6	Thickness	2.8	mm
7	Weight	30.1	g

CONFIDENTIAL



4. Maximum ratings:

Symbol	Parameter	Value	Unit
VCC	Logic Supply Voltage	-0.3 to +3.6	V
VCI	Analog Supply Voltage	-0.3 to +3.6	V

Table 7.1 Maximum ratings

Maximum ratings are those values beyond which damages to the device may occur. Functional operation should be restricted to the limits in the Electrical Characteristics tables or Pin Description section. Unused outputs must be left open.

CONFIDENTIAL



5. Electrical Characteristic:

DC Characteristic

DC Characteristics

(Unless otherwise specified, Voltage Referenced to VSS = 0V, VCC = 1.5 to 3.6V, T_A = -20 to 70C)

Parameter	Symbol	Test condition	Min.	Typ.	Max.	Unit
System power supply pins of the logic block	VCC		1.5		3.6	V
Booster Reference Supply Voltage Range	VCI		3.0		3.6	V
DDVDH Output Voltage 1	DDVDH	Set CP1X=0	4.9	5.1	5.3	V
DDVDH Output Voltage 2	DDVDH	Set CP1X=1	5.8	6.0	6.2	V
VGAM1OUT Output Voltage 1	VGAM1OUT	Set CP1X=0	4.7	4.8	4.9	V
VGAM1OUT Output Voltage 2	VGAM1OUT	Set CP1X=1	5.7	5.8	5.9	V
Gate driver High Output Voltage	VGH		+3		+8	V
Gate driver Low Output Voltage	VGL		8		3	V
OLED Diode Refer Voltage	ARREF		8		+8	V
Logic High Output Voltage	VOH	I _{out} = 400μA	0.8 * VCC		VCC	V
Logic Low Output Voltage	VOL	I _{out} =400μA	0		0.2 * VCC	V
Logic High Input voltage	VIH		0.8 * VCC		VCC	V
Logic Low Input voltage	VIL		0		0.2 * VCC	V
Logic Input Current	IIL/IIH	No pull up or pull low	1		1	μA
Pull high resistance	RH	Pull up pins	600	900	1200	KΩ
Pull low resistance	RL	Pull low pins	600	900	1200	KΩ
High Output Current	IOH	S1~S107, V _o =4.9V vs. 4V	50			μA
Low Output Current	IOL	S1~S107, V _o =0.1V vs. 1V			50	μA
Output leakage Current	IOZ		1		1	μA
Output voltage offset	VOS	S1~S107, V _o =0.1V~DDVDH 0.1V		±10		mV
Output voltage deviation	VOD	S1~S107, V _o =0.1V~DDVDH 0.1V		±10		mV
Analog standby current	ISTB	VCI=3.0V, Stand by mode			10	uA
Analog operating current	IVCI	VCI=3.0V, S1~S160 no load			20	mA
Logic Pins Input Capacitance	CIN			5	7.5	pF

CONFIDENTIAL



AC Characteristic

AC Electrical Characteristics

PARAMETER	Symbol	Min.	Typ.	Max.	Unit
HSYNC setup time	T_{hst}	10	-	-	ns
HSYNC hold time	T_{hhd}	10	-	-	ns
VSYNC setup time	T_{vst}	10	-	-	ns
VSYNC hold time	T_{vhd}	10	-	-	ns
Data setup time	T_{dsu}	10	-	-	ns
Data hold time	T_{dhd}	10	-	-	ns
DE setup time	T_{esu}	10	-	-	ns
VSYNC falling to HSYNC falling time on odd field @ RGB mode	T_{HV_O}	-4	0	+4	T_{CPH}
VSYNC falling to HSYNC falling time on even field @ RGB mode	T_{HV_E}	0.4	0.5	0.6	T_H
Source output settling time	T_{ST}	-	3	-	μs
Source output loading R	R_{SL}	-	25	-	K ohm
Source output loading C	C_{SL}	-	16	-	pF
Gate signals settling time (90%)	T_{GL}	-	0.5	-	μs
Gate signals loading R	R_{GL}	-	5.6	-	K ohm
Gate signals loading C	C_{GL}	-	30	-	pF
SW signals settling time (90%)	T_{SW}	-	0.6	-	μs
SW signals loading R	R_{SW}	-	1.4	-	K ohm
SW signals loading C	C_{SW}	-	85.5	-	pF

CONFIDENTIAL



5.2.2 480RGB X 272 serial RGB interface

PARAMETER	Symbol	Min.	Typ.	Max.	Unit
DCLK frequency	F_{CPH}	33.3	-	-	MHz
DCLK period	T_{CPH}	-	-	30	ns
DCLK pulse duty	T_{CWH}	40	50	60	%
HSYNC period	T_H	-	1836	-	T_{CPH}
HSYNC pulse width	T_{WH}	5	90	-	T_{CPH}
HSYNC-first horizontal data time	T_{HBP}	274	306	337	T_{CPH}
DE pulse width	T_{EP}	-	1440	-	T_{CPH}
VSYNC pulse width	T_{WV}	1	3	5	T_H
VSYNC-1 st Data input (DE) time	T_{VBP}	4	20	35	T_H
VSYNC period	T_V	302	-	-	T_H

5.2.2 480RGB X 272 parallel RGB interface

PARAMETER	Symbol	Min.	Typ.	Max.	Unit
DCLK frequency	F_{CPH}	11.1	-	-	MHz
DCLK period	T_{CPH}	-	-	90	ns
DCLK pulse duty	T_{CWH}	40	50	60	%
HSYNC period	T_H	-	612	-	T_{CPH}
HSYNC pulse width	T_{WH}	5	30	-	T_{CPH}
HSYNC-first horizontal data time	T_{HBP}	70	102	133	T_{CPH}
DE pulse width	T_{EP}	-	480	-	T_{CPH}
VSYNC pulse width	T_{WV}	1	3	5	T_H
VSYNC-1 st Data input (DE) time	T_{VBP}	4	20	35	T_H
VSYNC period	T_V	302	-	-	T_H

CONFIDENTIAL

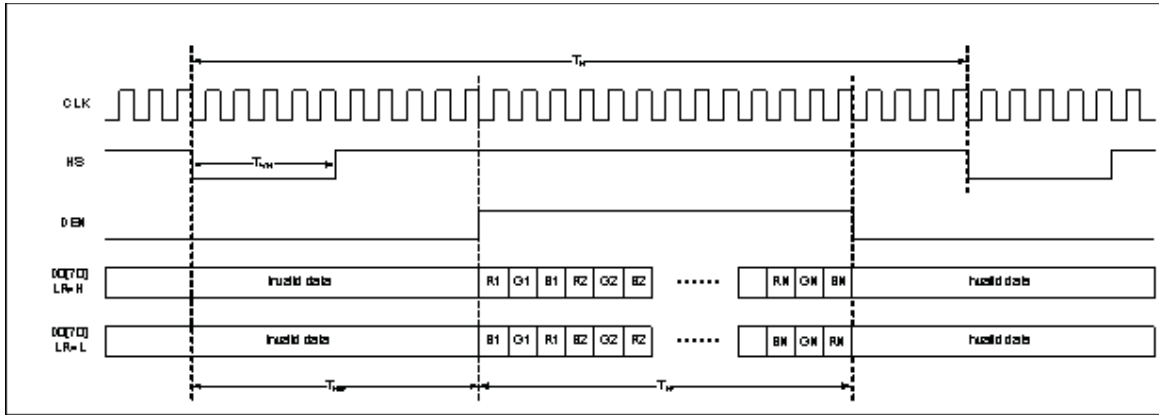

Serial RGB Horizontal Data Format

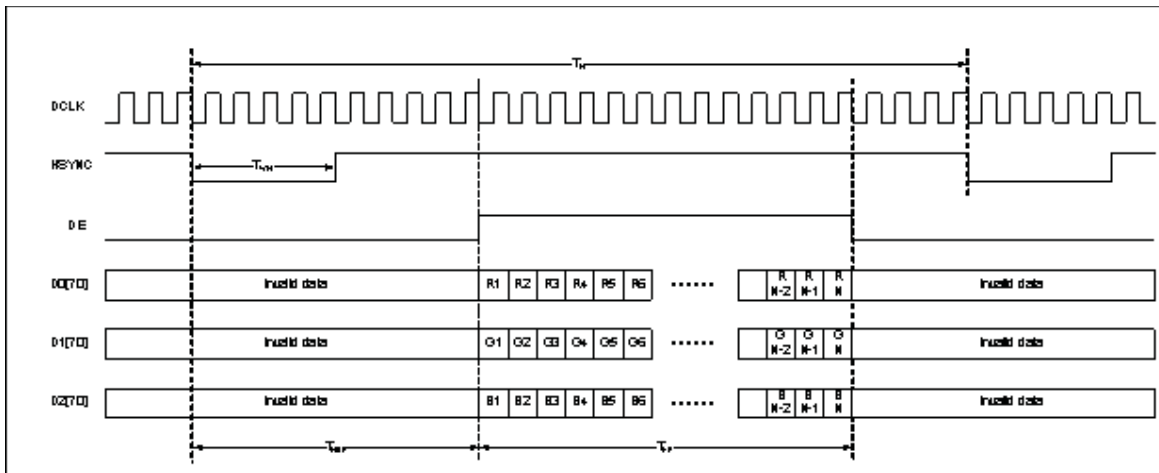

Parallel RGB Horizontal Data Format

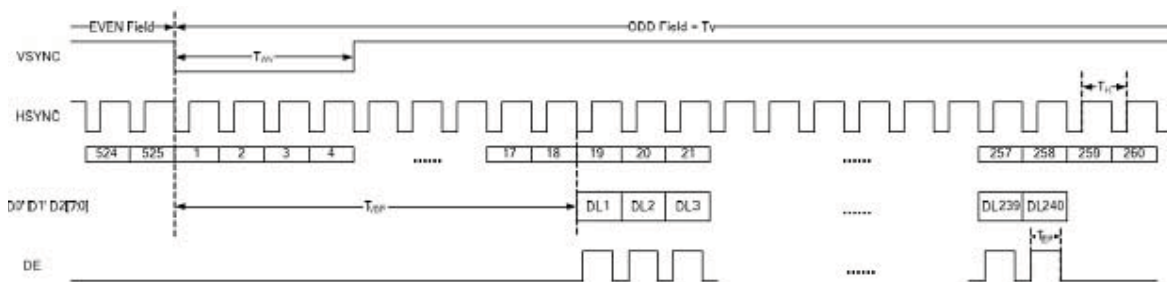

Digital RGB Vertical Data Format

CONFIDENTIAL



6. Electro-Optical Characteristic:

Items	Symbol	Min	Typ.	Max	Unit	Remark
Operating Luminance	L	136	160	184	Cd/m ²	(1)(5)
Power Consumption	Pon		500	680	mW	30% pixels on (1)
Maximum Current	Icc			210	mA	(1)
Response Time	Tres			50	uS	(2)
CIE _x (White)	W _x	0.23	0.28	0.33	-	(5)
CIE _y (White)	W _y	0.25	0.30	0.35	-	(5)
CIE _x (Red)	R _x	0.615	0.655	0.695	-	(5)
CIE _y (Red)	R _y	0.30	0.34	0.38	-	(5)
CIE _x (Green)	G _x	0.195	0.235	0.275	-	(5)
CIE _y (Green)	G _y	0.61	0.65	0.69	-	(5)
CIE _x (Blue)	B _x	0.10	0.14	0.18	-	(5)
CIE _y (Blue)	B _y	0.11	0.15	0.19	-	(5)
Viewing Angle	VA	160	170		Degree	(3)
Contrast	CR	5000:1	10000:1			(4)
Operation Lifetime	LTop	30000			Hrs	(1)(6)

Note:

Measuring surrounding: dark room

Surrounding temperature: 25°C

1. Test condition:

a. AR VDD= 5.0V +/-0.03V, AR VSS= -5.0V +/-0.03V

b. IC Initial Register Setting: (Gamma Setting Group : 7)

24-bit parallel RGB (DE)	Ver. 7
Index out(0x04); Parameter out(0x23); //set display mode 24-bit parallel RGB (DE)	
Index out(0x05); Parameter out(0x82); //set display mode	
Index out(0x07); Parameter out(0x0F); //set driver capability	
Index out(0x34); Parameter out(0x18); //set display timing	
Index out(0x35); Parameter out(0x28); //set display timing	

CONFIDENTIAL



CONFIDENTIAL

Index out(0x36);	Parameter out(0x16);	//set display timing
Index out(0x37);	Parameter out(0x01);	//set display timing
Index out(0x02);	Parameter out(0x02);	//OTP On
Index out(0x0A);	Parameter out(0x79);	//VGHVGL=+/-6V
Index out(0x09);	Parameter out(0x28);	//VGAM1OUT=5.02V
Index out(0x10);	Parameter out(0x77);	//set R slop
Index out(0x11);	Parameter out(0x76);	//set G slop
Index out(0x12);	Parameter out(0x77);	//set B slop
Index out(0x13);	Parameter out(0x00);	//set R 0
Index out(0x14);	Parameter out(0x00);	//set R 10
Index out(0x15);	Parameter out(0x00);	//set R 36
Index out(0x16);	Parameter out(0x00);	//set R 80
Index out(0x17);	Parameter out(0x00);	//set R 124
Index out(0x18);	Parameter out(0x00);	//set R 168
Index out(0x19);	Parameter out(0x01);	//set R 212
Index out(0x1A);	Parameter out(0x03);	//set R 255
Index out(0x1B);	Parameter out(0x00);	//set G 0
Index out(0x1C);	Parameter out(0x03);	//set G 10
Index out(0x1D);	Parameter out(0x00);	//set G 36
Index out(0x1E);	Parameter out(0x02);	//set G 80
Index out(0x1F);	Parameter out(0x01);	//set G 124
Index out(0x20);	Parameter out(0x02);	//set G 168
Index out(0x21);	Parameter out(0x02);	//set G 212
Index out(0x22);	Parameter out(0x06);	//set G 255
Index out(0x23);	Parameter out(0x00);	//set G 0
Index out(0x24);	Parameter out(0x02);	//set B 10
Index out(0x25);	Parameter out(0x01);	//set B 36
Index out(0x26);	Parameter out(0x02);	//set B 80
Index out(0x27);	Parameter out(0x02);	//set B 124
Index out(0x28);	Parameter out(0x03);	//set B 168
Index out(0x29);	Parameter out(0x03);	//set B 212
Index out(0x2A);	Parameter out(0x08);	//set B 255
Index out(0x06);	Parameter out(0x03);	//set display on
AR VDD= +5.0V		
AR VSS= -5.0V		



8-bit serial RGB (DE)		Ver. 7
Index out(0x04);	Parameter out(0x21); //set display mode 8-bit serial RGB (DE)	
Index out(0x05);	Parameter out(0x82); //set display mode	
Index out(0x07);	Parameter out(0x0F); //set driver capability	
Index out(0x34);	Parameter out(0x48); //set display timing	
Index out(0x35);	Parameter out(0x78); //set display timing	
Index out(0x36);	Parameter out(0x42); //set display timing	
Index out(0x37);	Parameter out(0x01); //set display timing	
Index out(0x02);	Parameter out(0x02); //OTP On	
Index out(0x0A);	Parameter out(0x79); //VGHVGL=+/-6V	
Index out(0x09);	Parameter out(0x28); //VGAM1OUT=5.02V	
Index out(0x10);	Parameter out(0x77); //set R slop	
Index out(0x11);	Parameter out(0x76); //set G slop	
Index out(0x12);	Parameter out(0x77); //set B slop	
Index out(0x13);	Parameter out(0x00); //set R 0	
Index out(0x14);	Parameter out(0x00); //set R 10	
Index out(0x15);	Parameter out(0x00); //set R 36	
Index out(0x16);	Parameter out(0x00); //set R 80	
Index out(0x17);	Parameter out(0x00); //set R 124	
Index out(0x18);	Parameter out(0x00); //set R 168	
Index out(0x19);	Parameter out(0x01); //set R 212	
Index out(0x1A);	Parameter out(0x03); //set R 255	
Index out(0x1B);	Parameter out(0x00); //set G 0	
Index out(0x1C);	Parameter out(0x03); //set G 10	
Index out(0x1D);	Parameter out(0x00); //set G 36	
Index out(0x1E);	Parameter out(0x02); //set G 80	
Index out(0x1F);	Parameter out(0x01); //set G 124	
Index out(0x20);	Parameter out(0x02); //set G 168	
Index out(0x21);	Parameter out(0x02); //set G 212	
Index out(0x22);	Parameter out(0x06); //set G 255	
Index out(0x23);	Parameter out(0x00); //set G 0	
Index out(0x24);	Parameter out(0x02); //set B 10	
Index out(0x25);	Parameter out(0x01); //set B 36	
Index out(0x26);	Parameter out(0x02); //set B 80	
Index out(0x27);	Parameter out(0x02); //set B 124	
Index out(0x28);	Parameter out(0x03); //set B 168	
Index out(0x29);	Parameter out(0x03); //set B 212	

CONFIDENTIAL

Index out(0x2A); Parameter out(0x08); //set B 255
Index out(0x06); Parameter out(0x03); //set display on
AR VDD= +5.0V
AR VSS= -5.0V

2. Response Time test condition

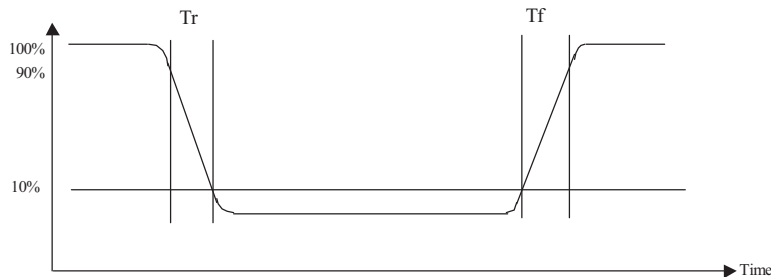

3. Viewing angle test condition:

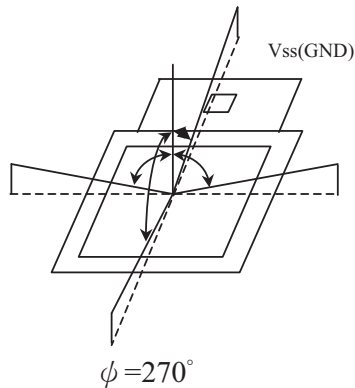

4. Contrast

$$CR = \frac{\text{Luminance with all pixels white}}{\text{Luminance with all pixels black}}$$

5. Optical tester: CA210

6. Brightness of 30% power consumption. Operating Life Time is defined when the luminance has decayed to less than 50% of the initial measured luminance before life test.

CONFIDENTIAL

7. System Diagram:

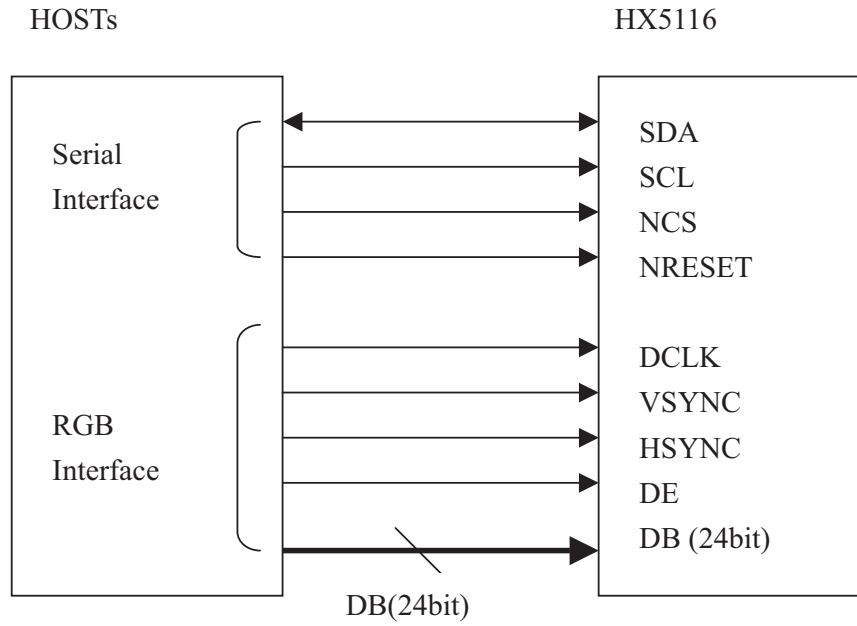

CONFIDENTIAL



8. Pin Assignment:

PIN	Symbol	I/O	Description	Remarks			
1	TP1	I	Touch panel P1				
2	TP2	I	Touch panel P2				
3	TP3	I	Touch panel P3.				
4	TP4	I	Touch panel P4				
5	AR VSS	I	Negative voltage for OLED				
6	AR VSS	I	Negative voltage for OLED				
7	TEST1 VS	open	CMEI test pin, it must be open.				
8	AR VDD	I	Positive voltage for OLED				
9	AR VDD	I	Positive voltage for OLED				
10	TEST2 VD	open	CMEI test pin, it must be open.				
11	ARREF	I/O	Panel refers voltage of the regulator ARREF or external input voltage. (-8V~+8V)				
12	VGL	I/O	Low Voltage output of regulator VGL or external input voltage. (-3V~-8V)				
13	VGH	I/O	High Voltage output of regulator VGH or external input voltage. (+3V~+8V)				
14	LVO	I/O	Negative output voltage of the booster2. (-8.5V)				
15	C22N	I/O	Connect to the step-up circuit, capacitors according to the step-up factor. Leave this pin open if the internal step-up circuit is not used.				
16	C22P						
17	HVO	I/O	Positive output voltage of the booster2. (8.5V)				
18	C21P	I/O	Connect to the step-up circuit, capacitors according to the step-up factor. Leave this pin open if the internal step-up circuit is not used.				
19	C21N						
20	C11N	I/O	Connect to the step-up circuit, 4capacitors according to the step-up factor. Leave this pin open if the internal step-up circuit is not used.				
21	C11P						
22	C12N						
23	C12P						
24	PVSS	P	Charge pump ground pin, it must connect to external ground.				
25	DDVDH	I/O	Output voltage of the booster1. (5.1V/6.0V)				
26	VSSA	P	Analog ground pin. It must connect to external ground.				
27	VSSA	P	Analog ground pin. It must connect to external ground.				
28	VCI	P	A power supply for the Analog circuit. (3.0V~3.6V)				
29	VCI	P	A power supply for the Analog circuit. (3.0V~3.6V)				
30	VGAM1OUT	I/O	Output voltage of the VGAM1OUT regulator and used positive power of source driver. (4.8V/5.8V)				
31	VDDD	I/O	Internal logic voltage input or output pin VDC_ENB 0, VDDD is output, please connect to 1uF capacitor.				
			<table border="1" style="display: inline-table; vertical-align: middle;"> <tr> <td>VDC0</td> <td>VDDD</td> <td>Status</td> </tr> </table>	VDC0	VDDD	Status	
VDC0	VDDD	Status					

CONFIDENTIAL



			0	1.8V	Normal display
			1	2.5V	OTP program
			VDC ENB=1, VDDD is input. (Input range = 1.6V~2.75V)		
32	VCC	P	A power supply for the Digital circuit. (1.5V~3.6V)		
33	VSSD	P	Digital ground pin. It must connect to external ground.		
34	NRESET	I	Reset pin. Setting either pin low initializes the LSI. Must be reset after power is supplied. (Normally pull high)		
35	NCS	I	Serial Interface chip enable pin. (Normally pull high)		
36	SCL	I	Serial Interface clock input pin. (Normally pull high)		
37	SDA	I	Serial Interface data line. (Normally pull high)		
38	DE	I	Data enable: When VSYNC+HSYNC+DE mode, DE H: Data enable, DE L: Data disable (Black). (Normally pull low)		
39	VSYNC	I	Frame synchronizing signal. If VSPL 0: Active low. If VSPL 1: Active high.		
40	HSYNC	I	Line synchronizing signal. If HSPL 0: Active low. If HSPL=1: Active high.		
41	DCLK	I	Dot clock signal. If DPL 0: Data are input on the rising edge of DOTCLK. If DPL=1: Data are input on the falling edge of DOTCLK.		
42	D27	I	Digital data input. DX0 is LSB and DX7 is MSB. (Normally pull low) 1. If parallel RGB input mode is used, D0X, D1X, and D2X indicate R, G, and B data in turn. 2. If serial RGB or RGBD or CCIR601 or CCIR656 input mode is selected, only D07~D00 are used, and others short to GND. DX7~DX0 has 8-bit width, respectively to compose 16,777,216 color and 256 gray scale of 1 pixel.		
43	D26				
44	D25				
45	D24				
46	D23				
47	D22				
48	D21				
49	D20				
50	D17				
51	D16				
52	D15				
53	D14				
54	D13				
55	D12				
56	D11				
57	D10				
58	D07				

CONFIDENTIAL



59	D06			
60	D05			
61	D04			
62	D03			
63	D02			
64	D01			
65	D00			
66	TEST3 W	open	C MEL test pin, it must be open.	
67	AR VDD	I	Positive voltage for OLED	
68	AR VDD	I	Positive voltage for OLED	
69	AR VSS	I	Negative voltage for OLED	
70	AR VSS	I	Negative voltage for OLED	
71	TEST4 P	open	C MEL test pin, it must be open.	

CONFIDENTIAL



9. External Dimension:

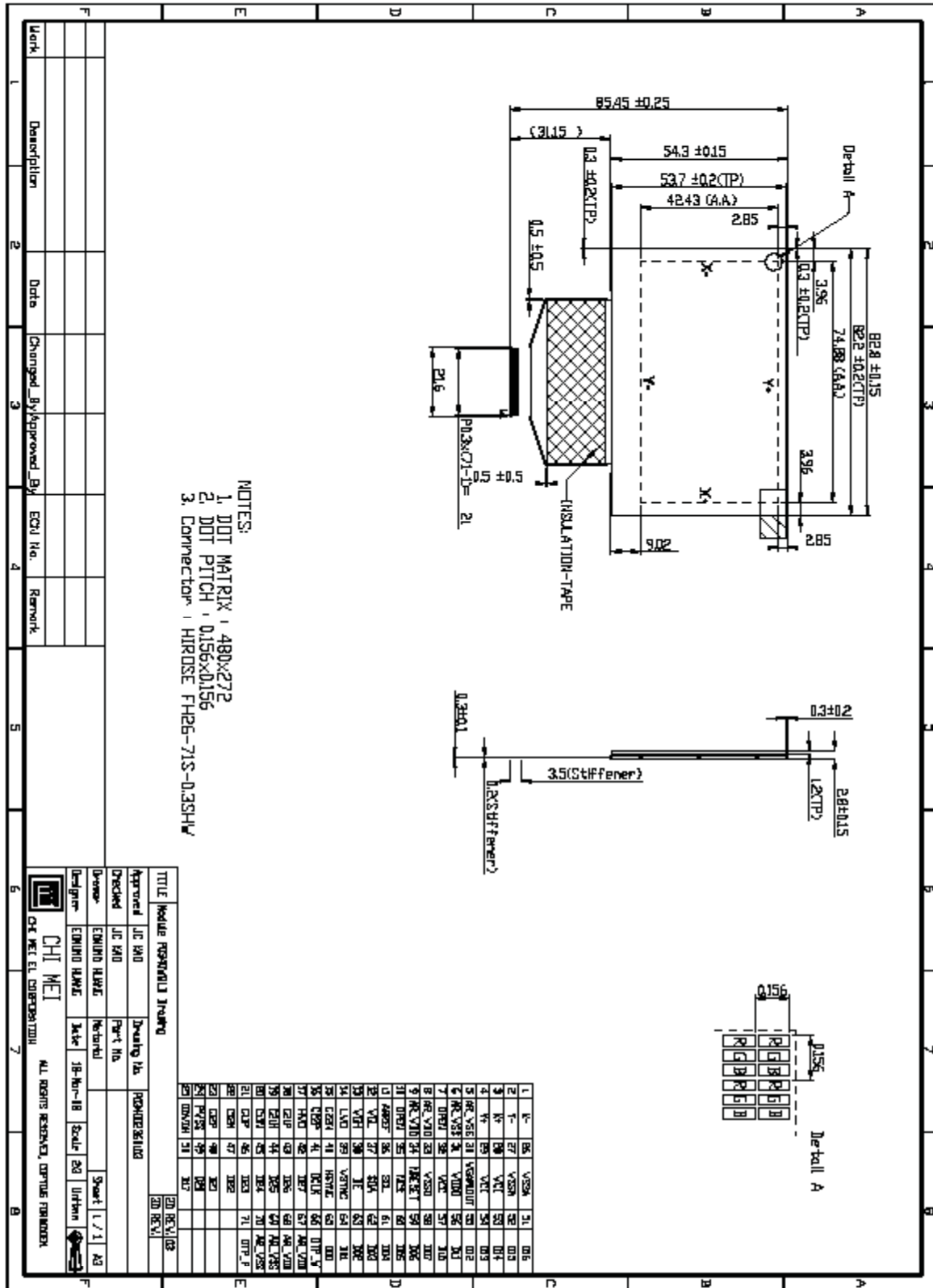

CONFIDENTIAL



10. Reliability Test:

No	Item	Specification
1	High Temp. Storage	85°C, 240hr
2	Low Temp. Storage	-40°C, 240hr
3	High Temp. Operation	60°C, 240hr
4	Low Temp. Operation	-40°C, 240hr
5	High Temp./ High Hum. Storage	85°C, 85 % RH, 240hr
6	High Temp./ High Hum. Operation	60°C, 90 % RH, 240hr
7	Thermal Shock storage	-40°C, 30 min. --> 85°C, 30 min., 100 cycles
8	ESD	TBD
9	Packing Test	TBD

CONFIDENTIAL

Test and measurement conditions

- All measurements shall not be started until the specimens attain to temperature stability.
- The degradation of Polarizer is ignored for item 1, 5 & 6.
- The test pattern at operating condition is 30%P.C. alternating pictures.

Evaluation Criteria

- No damage to glass or encapsulation
- No drastic change to display
- Defects / Mura follow product specification
- Luminance: Within +/-50% of initial value
- Current consumption: within +/-50% of initial value



11. Package:

1 One tray with 8 pcs panel module.

2 Take EPE sheet 1 pcs above the tray.

3 Take empty tray 1 pcs top of the substantial tray.

4 Circle the belt 1.5 loops around and fixed the trays by velcro(魔鬼氈).

5 Place one stack with a Drier into an anti-static bag.

6 Use clean tape to seal the bag.

7 Take EPE foam 2 pcs to hold one Bag.

8 Place three stacks into the carton.

9 One box package.

① Tray
Panel module

② EPE Sheet

x 1pcs(Empty)

x 10pcs(Panel 80pcs)

Belt Stack

Interface Stack

MP number label must upturn

FPC Pin direction must follow the arrowhead

Final Hot Sealing

S/N Label

Carton Label

③ Belt Start

④ Drier

⑤ Anti-Static Vacuum Bag

⑥ S/N Label (Must align the corner mark)

⑦ EPE Foam

⑧ Carton Label(Must align the corner point)

⑨ Carton

No.	Part Name	Q'ty	Unit	Part Number
1	Tray	33	pc	78-X000050
2	EPE Sheet	30	pc	78-X000051
3	Belt	6	pc	78-X000050
4	Drier	3	pc	78-X000001
5	Anti-Static vacuum bag	3	pc	78-X000006
6	S/N Label	3	pc	78-X000008
7	EPE Foam	6	pc	78-X000002
8	Carton Label	1	pc	78-X000011
9	Carton	1	box	78-X000009

TITLE		PCB/ENCL B/C/F PACKAGE DRAWING	
Approved	JC KAO	Drawing No.	PQ340023308A
Checked	LXY TSAI	Port No.	
Drawer	EDMUND HANG	Material	
Designer	EDMUND HANG	Date	24,SEP,08
		Scale	
		Sheet	1 / 1
		Unit	MM

20 REV. A
30 REV.

CHI MEI EL CORPORATION ALL RIGHTS RESERVED. COPYING FORBIDDEN

CONFIDENTIAL



US Micro Products

Electronic Products for the OEM

Los Angeles • Austin • New York • Orlando • Shenzhen

(800) 741-7755

www.usmicroproducts.com

Displays

US Micro Products is an industrial distributor specializing in engineered display solutions. We dedicate ourselves to providing the best in displays for the medical, industrial, gaming, automotive, aerospace, military, and consumer markets.

OLEDs



TFT Displays



Open Frame Monitors



Passive LCDs



Multitouch



As a customer, you benefit from our expert knowledge, support and service which allow quick selection and design-in of the best display for your application. On hand stock and demo boards facilitate quick access and evaluation to get you going fast. Our technical sales staff and experienced design engineers provide answers to your questions as well as engineered solutions to solve your display needs.

Peripheral Devices

Our full line of peripheral devices includes keyboards, trackballs, and printers. These rugged industrial products are designed to meet your demanding requirements and are available as both standard and custom solutions.

Keyboards



Trackballs



Aerospace Trackballs



Joysticks



Printers

