

PMOLED SPECIFICATION

Part Number	USMP-P015-128128LBI-B0
Size	1.46"
Resolution	128 x 128
Color	262K & 65K colors
IC	SSD1351
Brightness	90 cd/m ²
Contrast	2000:1
Operating temp.	-40 to 70 °C

FOR ADDITIONAL INFORMATION
PLEASE CONTACT:
engineering@usmicroproducts.com

Issue Date	Approved by (customer use)	Checked by	Prepared by

PROPRIETARY NOTE: THIS SPECIFICATION IS THE PROPERTY OF US MICRO PRODUCTS AND SHALL NOT BE REPRODUCED OR COPIED WITHOUT THE WRITTEN PERMISSION OF US MICRO PRODUCTS AND MUST BE RETURNED TO US MICRO PRODUCTS UPON ITS REQUEST.

(800) 741-7755
www.usmicroproducts.com

REVISION RECORD

REV.	REVISION DESCRIPTION	REV. DATE	REMARK
X01	INITIAL RELEASE	2010. 03. 23	
X02	<ul style="list-style-type: none"> • Add the lifetime specifications • Add the panel electrical specifications • Add the application circuit 	2010. 03. 30	Page 6, 7, 8 & 14
X03	<ul style="list-style-type: none"> • Modify FPC dimension • Add double sides tape 	2010. 05. 11	Page 4, 5 & 16
X04	<ul style="list-style-type: none"> • Add silk line on FPC • Modify double tape dimension • Add Mylar • Add bar code label 	2010. 10. 13	Page 16
A01	<ul style="list-style-type: none"> • Transfer from X version • Add the information of module weight • Add the packing specification 	2012. 11. 15	Page 5 & 17

CONTENTS

ITEM	PAGE
1. SCOPE	4
2. WARRANTY	4
3. FEATURES	4
4. MECHANICAL DATA	5
5. MAXIMUM RATINGS	6
6. ELECTRICAL CHARACTERISTICS	8
6.1 D.C ELECTRICAL CHARACTERISTICS	
6.2 ELECTRO-OPTICAL CHARACTERISTICS	
7. INTERFACE	9
7.1 FUNCTION BLOCK DIAGRAM	
7.2 PANEL LAYOUT DIAGRAM	
7.3 PIN ASSIGNMENTS	
7.4 GRAPHIC DISPLAY DATA RAM ADDRESS MAP	
7.5 INTERFACE TIMING CHART	
8. POWER ON / OFF SEQUENCE & APPLICATION CIRCUIT	13
8.1 POWER ON / OFF SEQUENCE	
8.2 APPLICATION CIRCUIT	
8.3 COMMAND TABLE	
9. RELIABILITY TEST CONDITIONS	15
10. EXTERNAL DIMENSION	16
11. PACKING SPECIFICATION	17
12. APPENDIXES	18

1.SCOPE

The purpose of this specification is to define the general provisions and quality requirements that apply to the supply of display cells manufactured by USMP. This document, together with the Module Ass'y Drawing, is the highest-level specification for this product. It describes the product, identifies supporting documents and contains specifications.

2.WARRANTY

USMP warrants that the products delivered pursuant to this specification (or order) will conform to the agreed specifications for twelve (12) months from the shipping date ("Warranty Period"). USMP is obligated to repair or replace the products which are found to be defective or inconsistent with the specifications during the Warranty Period without charge, on condition that the products are stored or used as the conditions specified in the specifications. Nevertheless, USMP is not obligated to repair or replace the products without charge if the defects or inconsistency are caused by the force majeure or the reckless behaviors of the customer.

After the Warranty Period, all repairs or replacements of the products are subject to charge.

3.FEATURES

- Small molecular organic light emitting diode.
- Color : 262K color and 65K colors
- Panel matrix : 128*128
- Driver IC : SSD1351
- Excellent quick response time.
- Extremely thin thickness for best mechanism design : 1.71mm
- High contrast : 2000:1
- Wide viewing angle : 160°
- Strong environmental resistance.
- 8-bit 6800-series Parallel Interface, 8-bit 8080-series Parallel Interface, Serial Peripheral Interface.
- Wide range of operating temperature : -40 to 70 °C.
- Anti-glare polarizer.

4.MECHANICAL DATA

NO	ITEM	SPECIFICATION	UNIT
1	Dot Matrix	128 (W) x (RxGxB) x 128 (H)	dot
2	Dot Size	0.0435 (W) x 0.1855 (H)	mm ²
3	Dot Pitch	0.0685 (W) x 0.2055 (H)	mm ²
4	Aperture Rate	57	%
5	Active Area	26.279 (W) x 26.284 (H)	mm ²
6	Panel Size	33.5 (W) x 33.5 (H)	mm ²
7*	Panel Thickness	1.42 ± 0.1	mm
8	Module Size	33.5 (W) x 49.83 (H) x 1.71 (D)	mm ³
9	Diagonal A/A size	1.46	inch
10	Module Weight	4.04 ± 10%	gram

* Panel thickness includes substrate glass, cover glass and UV glue thickness.

5. MAXIMUM RATINGS

ITEM	MIN	MAX	UNIT	Condition	Remark
Supply Voltage (V _{Cl})	-0.3	4	V	Ta = 25°C	IC maximum rating
Supply Voltage (V _{CC})	10	19	V	Ta = 25°C	IC maximum rating
Supply Voltage (V _{DDIO})	-0.5	V _{Cl}	V	Ta = 25°C	IC maximum rating
Operating Temp.	-40	70	°C		
Storage Temp	-40	85	°C		
Humidity	-	85	%		
Life Time	11,000	-	Hrs	90 cd/m ² , 50% checkerboard	Note (1)
Life Time	14,000	-	Hrs	70 cd/m ² , 50% checkerboard	Note (2)

Note:

(A) Under V_{CC} = 16.5V, Ta = 25°C, 50% RH.

(B) Life time is defined the amount of time when the luminance has decayed to less than 50% of the initial measured luminance.

(1) Setting of 90 cd/m² :

- Master contrast setting : 0x0b
- Red contrast setting : 0x70
- Green contrast setting : 0x71
- Blue contrast setting : 0x94
- Frame rate : 105Hz
- Duty setting : 1/128

(2) Setting of 70 cd/m² :

- Master contrast setting : 0x09
- Red contrast setting : 0x66
- Green contrast setting : 0x6a
- Blue contrast setting : 0x89
- Frame rate : 105Hz
- Duty setting : 1/128

6. ELECTRICAL CHARACTERISTICS

6.1 D.C ELECTRICAL CHARACTERISTICS

SYMBOL	PARAMETERS	TEST CONDITION	MIN	TYP	MAX	UNIT
V_{CC}	Analog power supply (for OLED panel)		16	16.5	17	V
V_{CI}	Digital power supply		2.4	-	3.5	V
V_{DDIO}	I/O voltage power supply		1.65	-	V_{CI}	V
I_{DD}	$V_{CI} = V_{DDIO} = 3.5V$, $V_{CC} = 16V$, External $V_{DD} = 2.6V$, Display ON, No panel attached, contrast = FF			170	190	μA
I_{DDIO}	$V_{CI} = V_{DDIO} = 3.5V$, $V_{CC} = 16V$, Display ON, No panel attached, contrast = FF	External VDD = 2.6V		0.5	10	μA
		Internal VDD		0.5	10	μA
I_{CI}	$V_{CI} = V_{DDIO} = 3.5V$, $V_{CC} = 16V$, Display ON, No panel attached, contrast = FF	External VDD = 2.6V	-	60	70	μA
		Internal VDD		255	280	μA
I_{CC}	$V_{CI} = V_{DDIO} = 3.5V$, $V_{CC} = 16V$, Display ON, No panel attached, contrast = FF	External VDD = 2.6V	-	1.15	1.26	mA
		Internal VDD		1.15	1.26	mA
V_{IH}	Hi logic input level		0.8* V_{DDIO}	-	V_{DDIO}	V
V_{IL}	Low logic input level		0	-	0.2* V_{DDIO}	V
V_{OH}	Hi logic output level		0.9* V_{DDIO}	-	V_{DDIO}	V
V_{OL}	Low logic output level		0	-	0.1* V_{DDIO}	V
I_{SEG}	Segment Output Current Setting $V_{CC} = 16V$ at $I_{REF} =$ 12.5 μA	Contrast=FF	-	200	-	μA
		Contrast=7F	-	100	-	μA
		Contrast=3F	-	50	-	μA

6.2 ELECTRO-OPTICAL CHARACTERISTICS

PANEL ELECTRICAL SPECIFICATIONS

PARAMETER	MIN	TYP.	MAX	UNITS	COMMENTS
Normal mode current		30	32	mA	All pixels on (1)
Standby mode current		3	4	mA	Standby mode 10% pixels on (2)
Normal mode power consumption		495	528	mW	All pixels on (1)
Standby mode power consumption		49.5	66	mW	Standby mode 10% pixels on (2)
Normal mode Luminance	70	90		cd/m ²	Display Average
Standby mode Luminance		20		cd/m ²	
CIE _x (White)	0.24	0.28	0.32		x, y (CIE 1931)
CIE _y (White)	0.28	0.32	0.36		
CIE _x (Red)	0.62	0.66	0.70		
CIE _y (Red)	0.29	0.33	0.37		
CIE _x (Green)	0.26	0.30	0.34		
CIE _y (Green)	0.59	0.63	0.67		
CIE _x (Blue)	0.10	0.14	0.18		
CIE _y (Blue)	0.14	0.18	0.22		
Dark Room Contrast	2000:1				
Viewing Angle	160			degree	
Response Time		10		μs	

(1) Normal mode condition :

- Driving Voltage : 16.5V
- Master contrast setting : 0x0b
- Red contrast setting : 0x70
- Green contrast setting : 0x71
- Blue contrast setting : 0x94
- Frame rate : 105Hz
- Duty setting : 1/128

(2) Standby mode condition :

- Driving Voltage : 16.5V
- Master contrast setting : 0x04
- Red contrast setting : 0x4e
- Green contrast setting : 0x53
- Blue contrast setting : 0x6e
- Frame rate : 105Hz
- Duty setting : 1/128

7. INTERFACE

7.1 FUNCTION BLOCK DIAGRAM

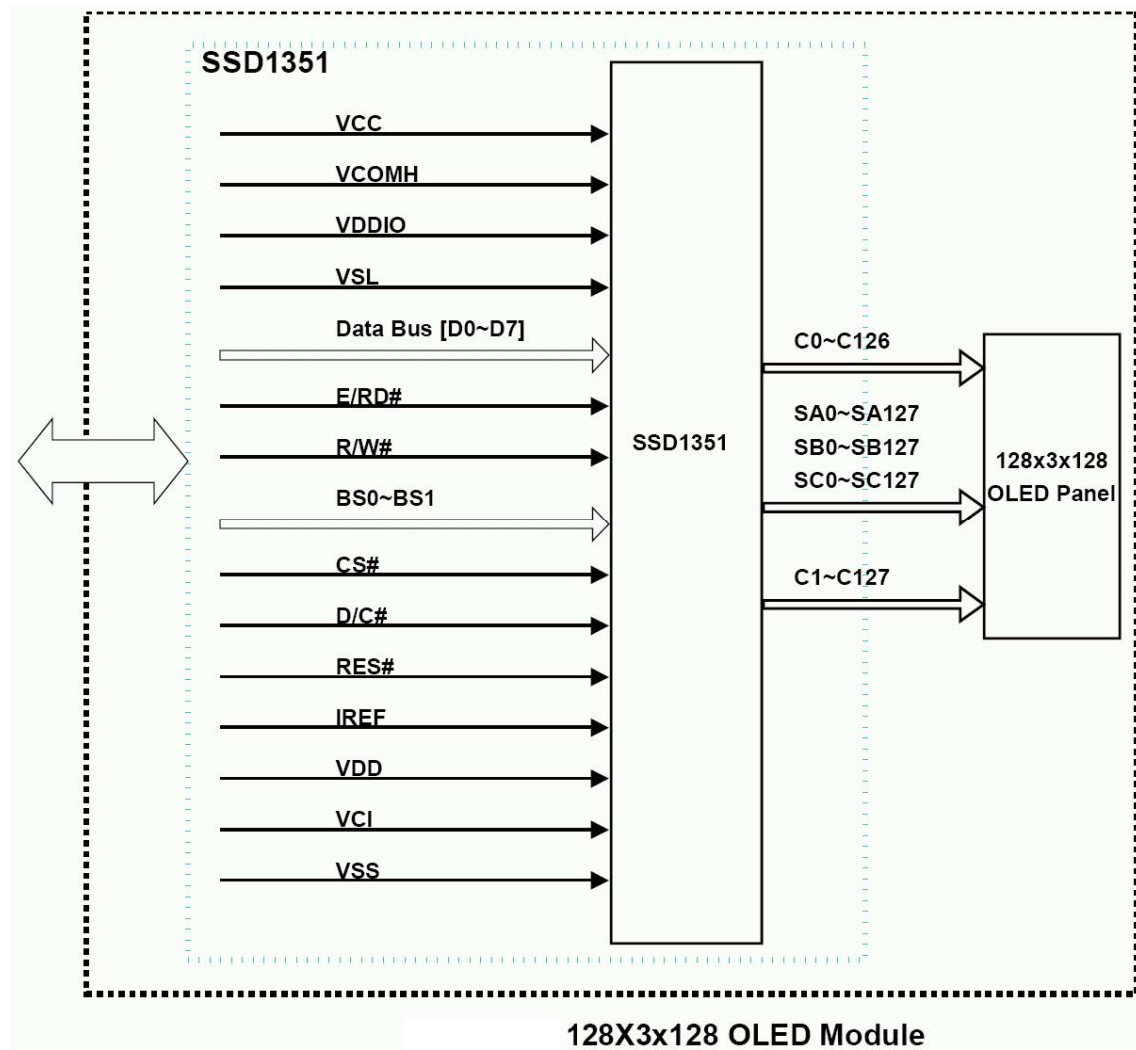

7.2 PANEL LAYOUT DIAGRAM

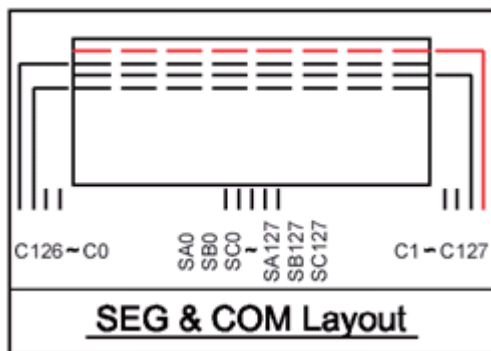

7.3 PIN ASSIGNMENTS

PIN NAME	PIN NO	DESCRIPTION
NC(GND)	1	Ground.
VCC	2	Power supply for panel driving voltage.
VCOMH	3	COM signal deselected voltage level. A capacitor should be connected between this pin an VSS.
VDDIO	4	Power supply for interface logic level.
VSL	5	This is segment voltage reference pin.
NC	6	No connection.
D7	7	These pins are bi-directional data bus connecting to the MCU data bus.
D6	8	
D5	9	
D4	10	
D3	11	
D2	12	
D1	13	
D0	14	
E/RD#	15	8080: data read enable pin; 6800:Read/Write enable pin.
R/W#	16	8080: data write enable pin; 6800:Read/Write select pin.
BS0	17	Interface select pin.
BS1	18	
CS#	19	Chip select pin.
D/C#	20	H: Data, L: Command.
RES#	21	Hardware Reset pin (Low active).
IREF	22	A resistor should be connected between this pin and VSS.
NC	23	No connection.
NC	24	No connection.
NC	25	No connection.
VDD	26	Power supply pin for core logic operation.
VCI	27	Digital voltage power supply.
VSS	28	Ground.
NC	29	No connection.
NC(GND)	30	Ground.

7.4 GRAPHIC DISPLAY DATA RAM ADDRESS MAP

The GDDRAM is a bit mapped static RAM holding the pattern to be displayed. The RAM size is 128 x 128 x 18bits. For mechanical flexibility, re-mapping on both Segment and Common outputs can be selected by software. Each pixel has 18-bit data. Each sub-pixels for color A, B and C have 6 bits. The arrangement of data pixel in graphic display data RAM is shown below.

262k Color Depth Graphic Display Data RAM Structure

Segment Address	Normal	0			1			2	126	127		
	Remapped	127			126			125	1	0		
Color		A	B	C	A	B	C	A	C	A	B	C
Data Format	Common Address	A5	B5	C5	A5	B5	C5	A5	C5	A5	B5	C5
		A4	B4	C4	A4	B4	C4	A4	C4	A4	B4	C4
		A3	B3	C3	A3	B3	C3	A3	C3	A3	B3	C3
		A2	B2	C2	A2	B2	C2	A2	C2	A2	B2	C2
		A1	B1	C1	A1	B1	C1	A1	C1	A1	B1	C1
A0	B0	C0	A0	B0	C0	A0	C0	A0	B0	C0		
Normal	Remapped													Common output
0	127	6	6	6	6	6	6	6	6	6	6	
1	126	6	6	6	6	6	6	6	6	6	6	6
2	125	6	6	6	6	6	6	6	6	6	6	6
3	124	6	6	6	6	6	6	6	6	6	6	6
4	123	6	6	6	6	6	6	6	6	6	6	6
5	122	6	6	6	6	6	6	6	6	6	6	6
6	121	6	6	no of bits in this cell			6	6	6	6	6	6
7	120								6	6	6	6
:	:	:	:	:	:	:	:	:	:	:	:	:
:	:	:	:	:	:	:	:	:	:	:	:	:
:	:	:	:	:	:	:	:	:	:	:	:	:
123	4	6	6	6	6	6	6	6	6	6	6	6
124	3	6	6	6	6	6	6	6	6	6	6	6
125	2	6	6	6	6	6	6	6	6	6	6	6
126	1	6	6	6	6	6	6	6	6	6	6	6
127	0	6	6	6	6	6	6	6	6	6	6	6

SEGoutput	SA0	SB0	SC0	SA1	SB1	SC1	SA2	SC126	SA127	SB127	SC127
-----------	-----	-----	-----	-----	-----	-----	-----	-------	-------	-------	-------	-------	-------

7.5 INTERFACE TIMING CHART

8080-Series MCU Parallel Interface Timing Characteristics

($V_{DD} - V_{SS} = 2.4$ to $2.6V$, $V_{DDIO} = 1.65V$, $V_{CI} = 2.8V$, $T_A = 25^\circ C$)

Symbol	Parameter	Min	Typ	Max	Unit
t_{CYCLE}	Clock Cycle Time	300	-	-	ns
t_{AS}	Address Setup Time	10	-	-	ns
t_{AH}	Address Hold Time	0	-	-	ns
t_{DSW}	Write Data Setup Time	40	-	-	ns
t_{DHW}	Write Data Hold Time	7	-	-	ns
t_{DHR}	Read Data Hold Time	20	-	-	ns
t_{OH}	Output Disable Time	-	-	70	ns
t_{ACC}	Access Time	-	-	140	ns
t_{PWLr}	Read Low Time	150	-	-	ns
t_{PWLW}	Write Low Time	60	-	-	ns
t_{PWHr}	Read High Time	60	-	-	ns
t_{PWHW}	Write High Time	60	-	-	ns
t_R	Rise Time	-	-	15	ns
t_F	Fall Time	-	-	15	ns
t_{CS}	Chip select setup time	0	-	-	ns
t_{CSH}	Chip select hold time to read signal	0	-	-	ns
t_{CSF}	Chip select hold time	20	-	-	ns

8080-series MCU parallel interface characteristics

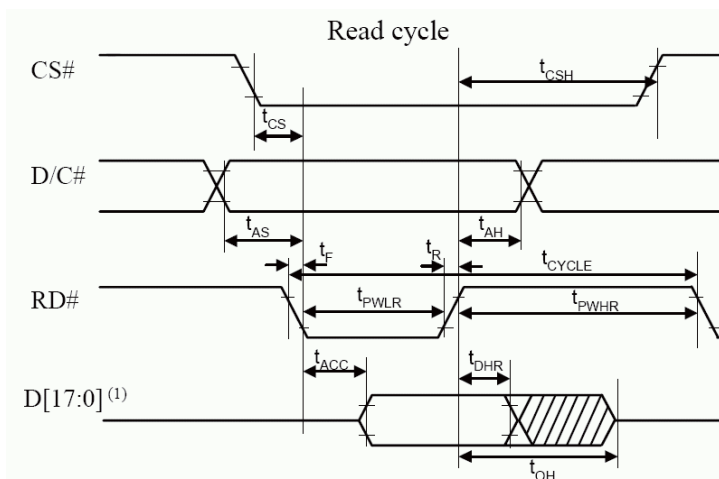
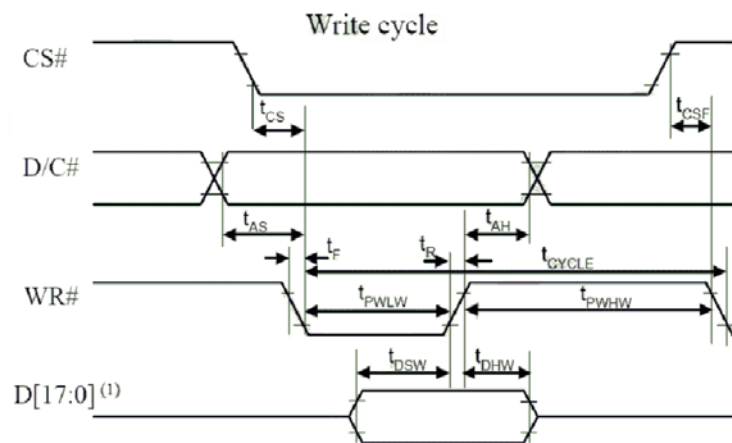

Note

(1) when 8 bit used: D[7:0] instead; when 16 bit used: [15:0] instead; when 18 bit used: D[17:0] instead.

8. POWER ON / OFF SEQUENCE & APPLICATION CIRCUIT

8.1 POWER ON / OFF SEQUENCE

The following figures illustrate the recommended power ON and power OFF sequence of SSD1351 (assume V_{CI} and V_{DDIO} are at the same voltage level and internal V_{DD} is used).

Power ON sequence:

1. Power ON V_{CI} , V_{DDIO} .
2. After V_{CI} , V_{DDIO} become stable, set wait time at least 1ms (t_0) for internal V_{DD} become stable. Then set RES# pin LOW (logic low) for at least 2us (t_1)⁽⁴⁾ and then HIGH (logic high).
3. After set RES# pin LOW (logic low), wait for at least 2us (t_2). Then Power ON V_{CC} .⁽¹⁾
4. After V_{CC} become stable, send command AFh for display ON. SEG/COM will be ON after 200ms(t_{AF}).

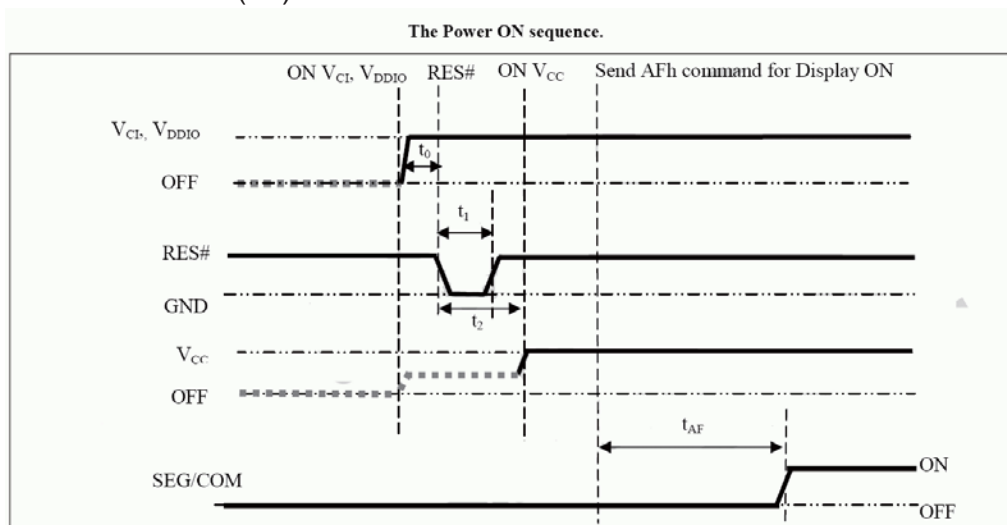

Power OFF sequence:

1. Send command AEh for display OFF.
2. Power OFF V_{CC} .^{(1), (2)}
3. Wait for t_{OFF} . Power OFF V_{CI} , V_{DDIO} . (where Minimum t_{OFF} =80ms⁽³⁾, Typical t_{OFF} =100ms)

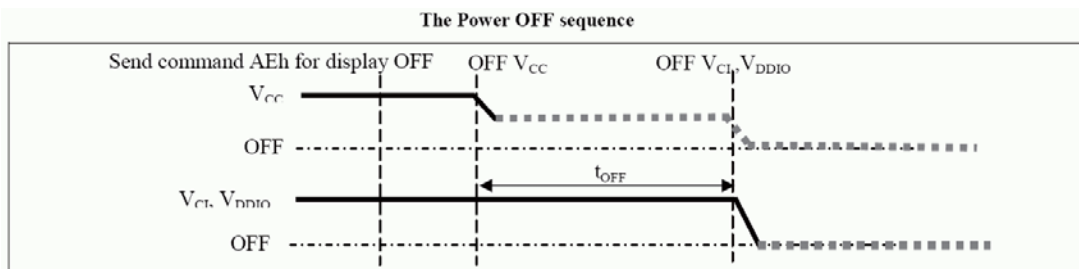

Note:

- (1) Since an ESD protection circuit is connected between V_{CI} , V_{DDIO} and V_{CC} , V_{CC} becomes lower than V_{CI} whenever V_{CI} , V_{DDIO} is ON and V_{CC} is OFF as shown in the dotted line of V_{CC} in above figures.
- (2) V_{CC} should be kept float (disable) when it is OFF.
- (3) V_{CI} , V_{DDIO} should not be Power OFF before V_{CC} Power OFF.
- (4) The register values are reset after t_1 .
- (5) Power pins (V_{DD} , V_{CC}) can never be pulled to ground under any circumstance.

8.2 APPLICATION CIRCUIT

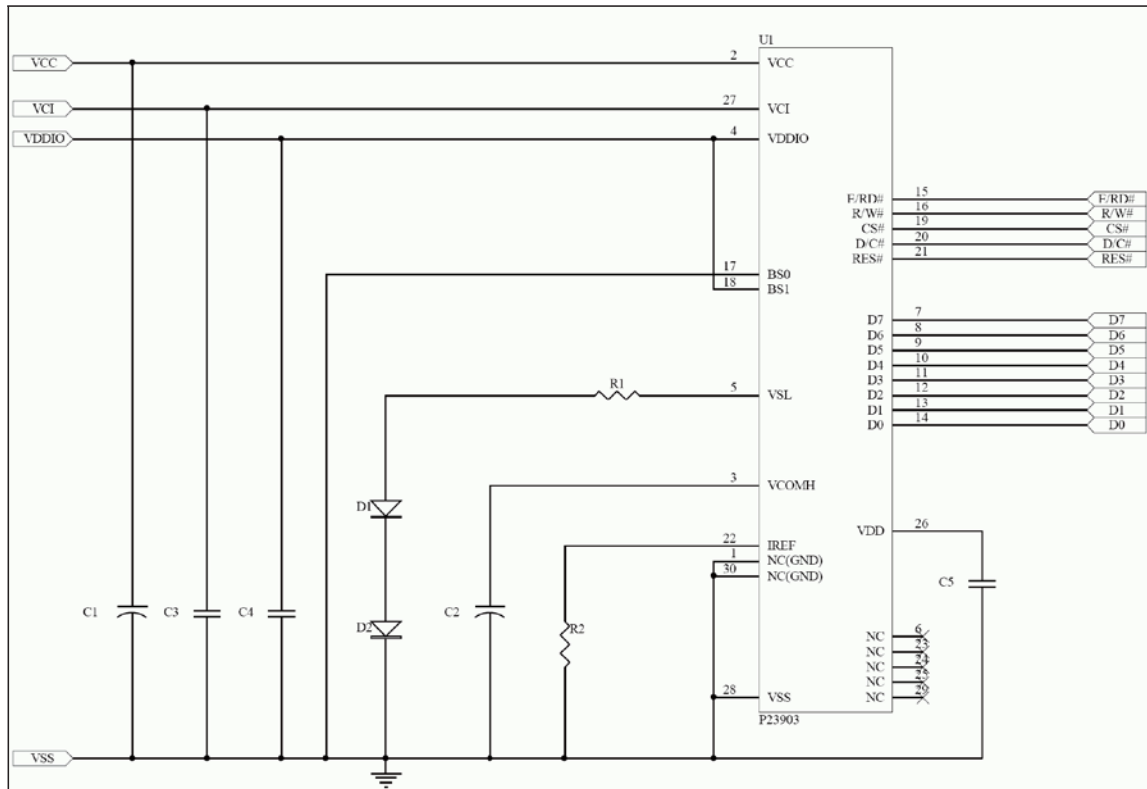

Recommend components:

C3, C4, C5: 1uF/16V(0805)

C1, C2: 4.7uF/35V (Tantalum type) or VISHAY (572D475X0025A2T)

R2: 1M ohm 1%(0603)

R1: 50 ohm 1/4W

D1, D2: RB480K(ROHM)

This circuit is for 8080 8bits interface

8.3 COMMAND TABLE

Refer to SSD1351 IC Spec.

9.RELIABILITY TEST CONDITIONS

No.	Items	Specification	Quantity
1	High temp. (Non-operation)	85°C, 240hrs	5
2	High temp. (Operation)	70°C, 120hrs	5
3	Low temp. (Operation)	-40°C, 120hrs	5
4	High temp. / High humidity (Operation)	65°C, 90%RH, 96hrs	5
5	Thermal shock (Non-operation)	-40°C ~85°C (-40°C /30min; transit /3min; 85°C /30min; transit /3min) 1cycle: 66min, 20 cycles	5
6	Vibration	Frequency : 5~50HZ, 0.5G Scan rate : 1 oct/min Time : 2 hrs/axis Test axis : X, Y, Z	1 Carton
7	Drop	Height: 120cm Sequence : 1 angle ,3 edges and 6 faces Cycles: 1	1 Carton
8	ESD (Non-operation)	Air discharge model, ±8kV, 10 times	5

Test and measurement conditions

1. All measurements shall not be started until the specimens attain to temperature stability.
2. All-pixels-on is used as operation test pattern.
3. The degradation of Polarizer are ignored for item 1, 4 & 5.

Evaluation criteria

1. The function test is OK.
2. No observable defects.
3. Luminance: > 50% of initial value.
4. Current consumption: within ± 50% of initial value.

10. EXTERNAL DIMENSION

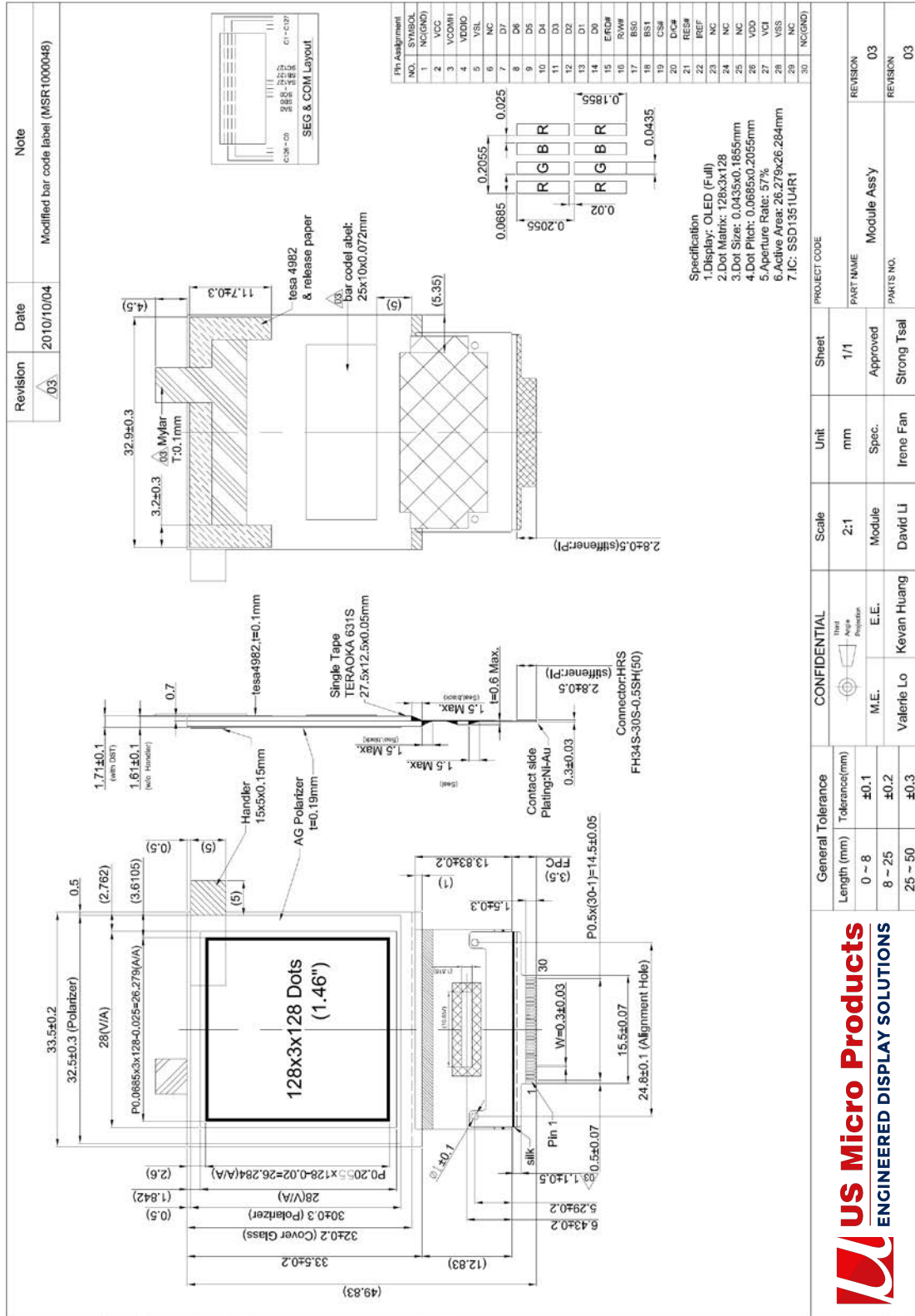

11. PACKING SPECIFICATION

Revision ▲01	Date 2012/11/15	Note Packing Tray Instruction
-----------------	--------------------	----------------------------------

① Module
P/N: 330x270x8.7mm, t=0.7mm
Face Up
取樣位置

② Packing Tray
P/N: 3008000103
330x270x8.7mm, t=0.7mm

③ 5G 封箱袋
P/N: 3010000003
x4

④ 真空包裝袋 ONY/LDPE
P/N: 300300000112
480x285x90mm
抽真空4秒

⑤ Antistatic Bubble Bag
P/N: 30030000016
440x(350+450)mm

⑥ Pizza Box
P/N: 30010000005
345x285x88, B 浪

⑦ 單色 Carton
P/N: 30000000009
385x305x203mm

⑧ Label
P/N: 30060000000
x2 pcs

⑨ 封箱膠帶
P/N: 3208000125

旋轉堆疊 x 20 pcs

封箱膠帶 P/N: 3208000125 x 21 pcs

旋轉堆疊 x 1 pcs (empty)

旋轉堆疊 x 20 pcs

封箱膠帶 P/N: 3208000125 x 1 pcs

Label P/N: 30060000000 x 1 pcs

Item	Part No.	Description	QTY
1		Module Assy	960
2	3008000103	Tray 330x270x8.7mm, t=0.7mm	42
3	3010000003	5G 封箱袋	8
4	30030000012	真空包裝袋 480x285x90mm	2
5	30030000016	Antistatic Bubble Bag 440x(350+450)mm	2
6	30010000005	Pizza Box 345x285x88, B 浪	2
7	30000000009	單色 Carton, 385x305x203mm	1
8	30060000000	Label	3
9	3208000125	封箱膠帶	

CONFIDENTIAL		PROJECT CODE
General Tolerance	Scale	Sheet
Length (mm)	1:9	1/1
0 ~ 8	Module	Approved
8 ~ 25	E.E.	Strong Tsai
25 ~ 50	Turbo Yeh	Irene Fan
±0.1	M.E.	David Li
±0.2	E.E.	Kevan Huang
±0.3	Third Angle Projection	David Li
PART NAME		REVISION
Packing Tray Instruction		01
PARTS NO.		REVISION
		01

12.APPENDIXES

APPENDIX 1: DEFINITIONS

A. DEFINITION OF CHROMATICITY COORDINATE

The chromaticity coordinate is defined as the coordinate value on the CIE 1931 color chart for R, G, B, W.

B. DEFINITION OF CONTRAST RATIO

The contrast ratio is defined as the following formula:

$$\text{Contrast Ratio} = \frac{\text{Luminance of all pixels on measurement}}{\text{Luminance of all pixels off measurement}}$$

C. DEFINITION OF RESPONSE TIME

The definition of turn-on response time T_r is the time interval between a pixel reaching 10% of steady state luminance and 90% of steady state luminance. The definition of turn-off response time T_f is the time interval between a pixel reaching 90% of steady state luminance and 10% of steady state luminance. It is shown in Figure 2.

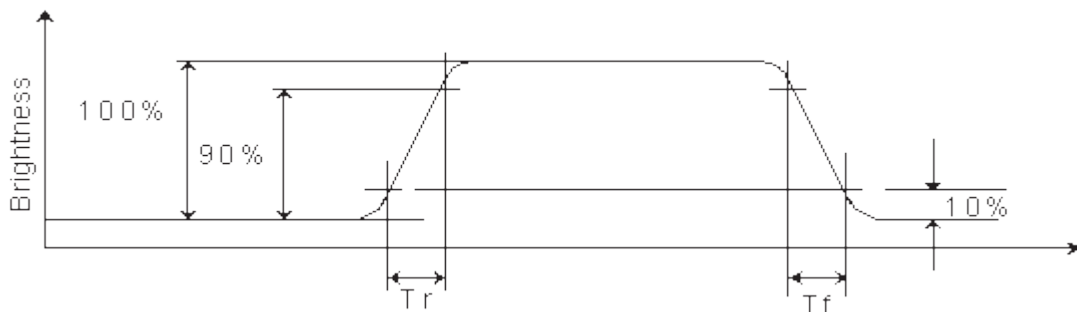

Figure 2: Response time

D. DEFINITION OF VIEWING ANGLE

The viewing angle is defined as Figure 3. Horizontal and vertical (H & V) angles are determined for viewing directions where luminance varies by 50% of the perpendicular value.

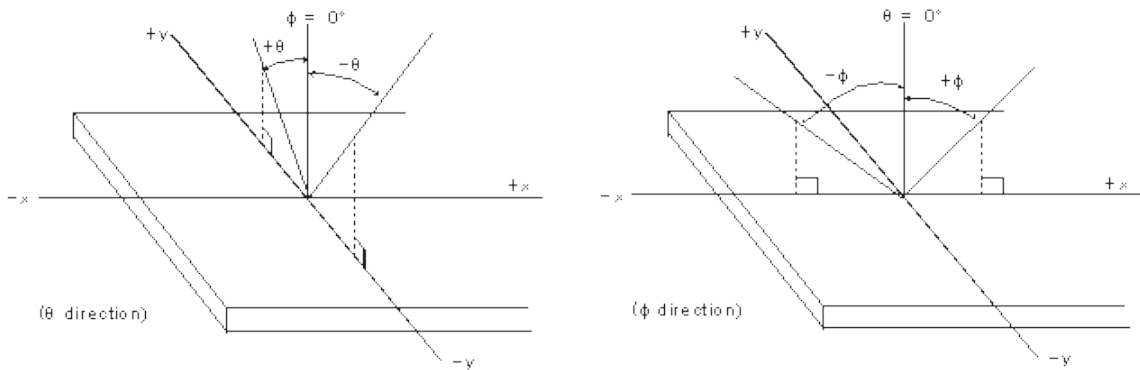
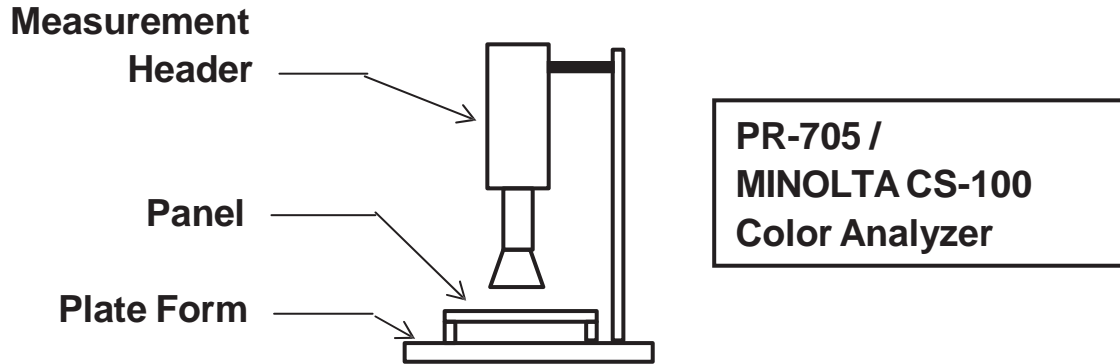

Figure 3: Viewing Angle

APPENDIX 2: MEASUREMENT APPARATUS

A. LUMINANCE/COLOR COORDINATE

PHOTO RESEARCH PR-705, MINOLTA CS-100



B. CONTRAST / RESPONSE TIME / VIEW ANGLE

WESTAR CORPORATION FPM-510

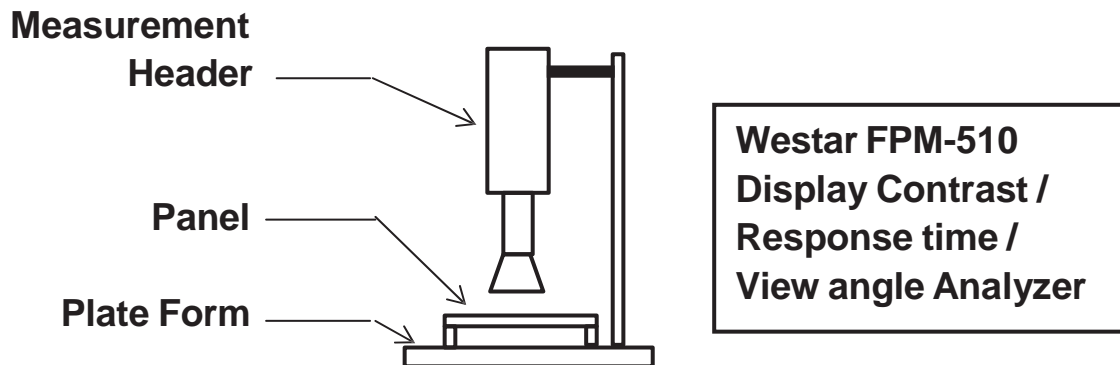

C. ESD ON AIR DISCHARGE MODE

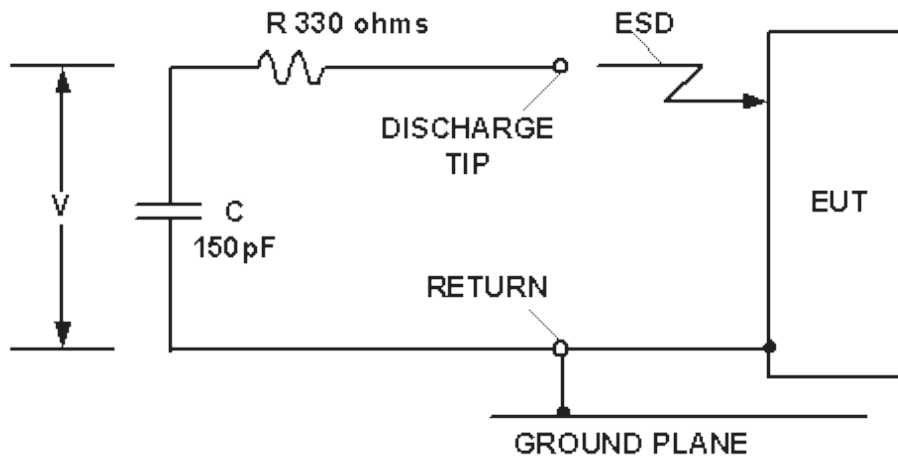

APPENDIX 3: PRECAUTIONS

A. RESIDUE IMAGE

Because the pixels are lighted in different time, the luminance of active pixels may reduce or differ from inactive pixels. Therefore, the residue image will occur. To avoid the residue image, every pixel needs to be lighted up uniformly.