

AMOLED SPECIFICATION

Part Number	USMP-A010-018012CBN-B2
Size	0.948"
Resolution	180 x 120
Brightness	350 cd/m ²
Contrast	100000:1
Viewing Angle	85/85/85/85
Operating Temp.	-20 ~ 70°C

FOR ADDITIONAL INFORMATION
PLEASE CONTACT:
engineering@usmicroproducts.com

Issue Date	Approved by (customer use)	Checked by	Prepared by

PROPRIETARY NOTE: THIS SPECIFICATION IS THE PROPERTY OF US MICRO PRODUCTS AND SHALL NOT BE REPRODUCED OR COPIED WITHOUT THE WRITTEN PERMISSION OF US MICRO PRODUCTS AND MUST BE RETURNED TO US MICRO PRODUCTS UPON ITS REQUEST.

(800) 741-7755
www.usmicroproducts.com

Reversion History			
Reversion. No	Date	Contents	Remark
01	2016-5-30	First Draft	
02	2016-9-28	Final Spec	ESD/image retention 等规格变更
03	2016-11-16	Final Spec	Luminance 增加上下 限/image retention 判定方式变更

Contents

Contents	3
1 Scope.....	4
2 Features	4
2.1 Product Applications.....	4
2.2 Product Features.....	4
3 Mechanical Specifications.....	4
4 Maximum Rating.....	4
5 Electrical Specifications.....	5
5.1 Electrical Characteristics.....	5
5.2 TP IC Recommended Operating Conditions.....	8
5.3 I/O Connection and Block Diagrams	8
5.4 Recommended Operating Sequence.....	10
6 Electro-Optical Specification.....	10
7 Reliability.....	17
7.1 Environmental Test.....	17
7.2 Electrical Test	17
7.3 Mechanical Test.....	17
8 Outline Dimension Drawing.....	18
9 Packing Specification.....	19

1 Scope

This Specification defines AMOLED manufactured by EverDisplay Optronics(Shanghai) Limited, from here on refer as USMP. In the case of any unspecified item, it may require both USMP and the party designs this module into its product to work out a solution.

2 Features

2.1 Product Applications

Smart Watch

2.2 Product Features

- 1) Display color: 16.7M (RGB x 8bits)
- 2) Display format: 0.95”(180RGBx120)
- 3) Pixel arrangement: Real RGB arrangement
- 4) Interface: SPI

3 Mechanical Specifications

Item	Specification	unit
Dimension outline	22.23 (W) x 18.32 (H) x 0.75 (T)	mm
LTPS Glass outline	22.23 x18.32	mm
Encapsulation Glass outline	22.23 x16.72	mm
Number of dots	180(W) x RGB x 120(H)	dots
Active area	20.03x13.36	mm
Diagonal size	0.948	inch
Pixel pitch	111.3 x 111.3	μm
Glass thickness (LTPS/encapsulation glass)	0.2 / 0.3	mm
Weight	0.83	g

4 Maximum Rating

Parameter	Symbol	Spec			Unit	Note
		Min.	Typ.	Max.		
Analog/boost power voltage	VCI	-0.3	-	5.5	V	-
I/O voltage	VDDIO	-0.3	-	5.5	V	-
Operating temperature	Top	-20	-	70	°C	-
Storage temperature	Tstg	-40	-	80	°C	-

5 Electrical Specifications

5.1 Electrical Characteristics

5.1.1 Power Characteristic:

Item	Symbol	Min.	Typ.	Max.	Unit	Remark
AMOLED Power positive	ELVDD	4.55	4.6	4.65	V	-
AMOLED power Negative	ELVSS	-2.45	-2.4	-2.35	V	Ref
Digital Power supply	VDDIO	1.65	1.8	1.95	V	Ref
Analog Power supply	VCI	2.7	2.8	2.9	V	Ref

1) Normal Mode

Power Supply: IOVCC=1.8V VCI=2.8V

Frame Frequency: $F_{frame}=60\text{HZ @ }25\text{degC}$, Brightness 350 nits, Command Mode,

Display Condition	Symbol	Min.	Typ.	Max.	Unit	Remark
100% Pixel On 350nits	IELVDD /ELVSS	-	8	8.8	mA	Ref
	IVCI	-	6.0	7.2	mA	Ref
	IVDDIO	-	5.8	6.0	mA	Ref
50% Pixel On 175nits	IELVDD /ELVSS	-	2.5	2.75	mA	Ref
	IVCI	-	6.6	8.0	mA	Ref
	IVDDIO	-	5.8	6.0	mA	Ref

2) Idle Mode

Power Supply: IOVCC=1.8V VCI=2.8V

Frame Frequency: $F_{frame}=15\text{HZ @ }25\text{degC}$, Brightness 30 nits,

Display Condition	Symbol	Min.	Typ.	Max.	Unit	Remark
10% Pixel On 30 nits	IELVDD /ELVSS	-	-	-	mA	Supplied by Driver IC
	IVCI	-	4.5	5.4	mA	Ref
	IVDDIO	-	1.5	1.8	mA	Ref

3) Deep Standby Mode

Display Condition	Symbol	Min.	Typ.	Max.	Unit	Remark
Deep Standby	IVCI	-	-	2	uA	-
	IVDDIO	-	-	1	uA	-

5.1.2 Power supply circuit application (This is for reference only):

1) RT4723A

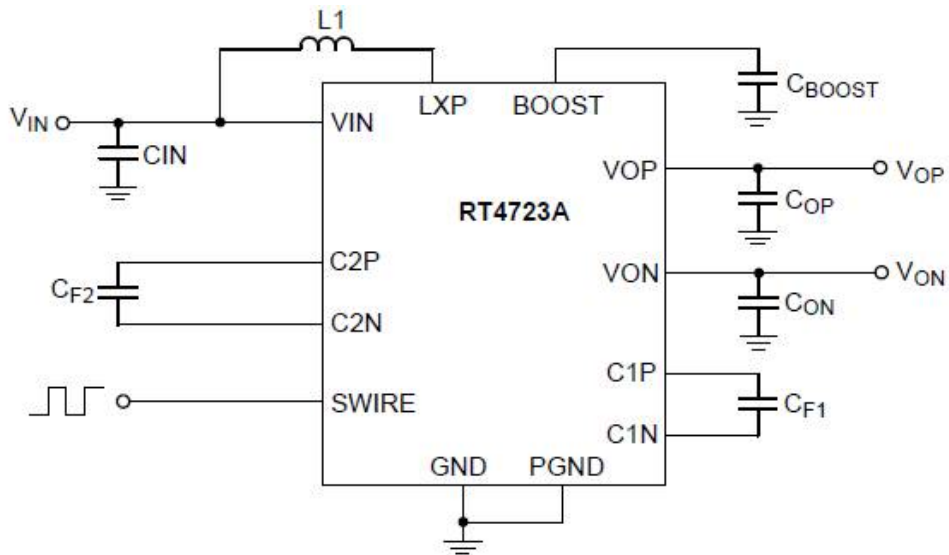

2) SM3321

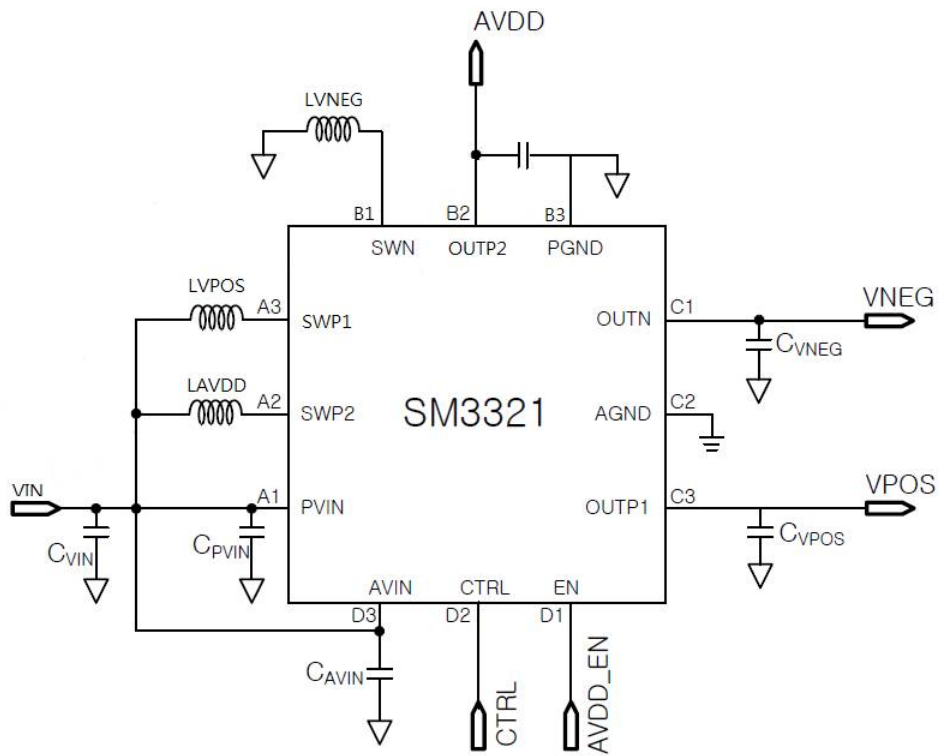

3) TPS65631W

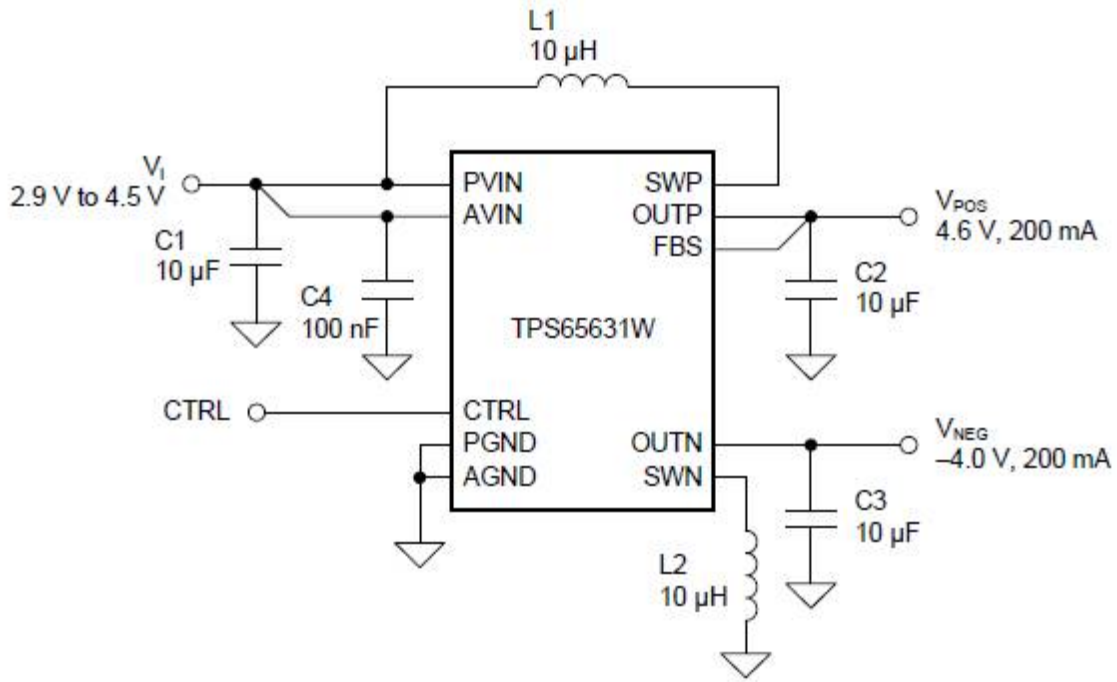

4) STAM1332

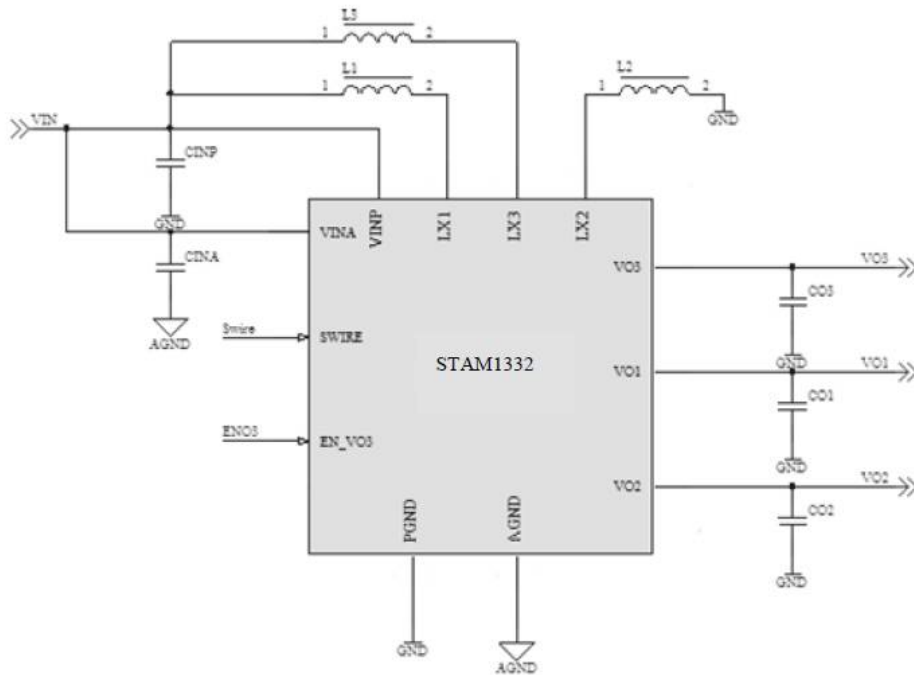

5.2 TP IC Recommended Operating Conditions

Symbol	Description	Min	TYP	MAX	UNIT
VCCA	Analog power supply voltage	2.7	3.3	3.6	V
V _{IN} (I2C)	Input voltage range	0	-	3.6	V
V _{OUT} (I2C)	Output voltage range	0	-	VBUS	V
V _{IN} (INT)	Input voltage range	0	-	3.6	V
V _{OUT} (INT)	Output voltage range	0	-	VBUS	V
V _{OUT} (TX)	Output voltage range	0	-	3.3	V
V _{OUT} (RX)	Input voltage range	0	-	3.3	V

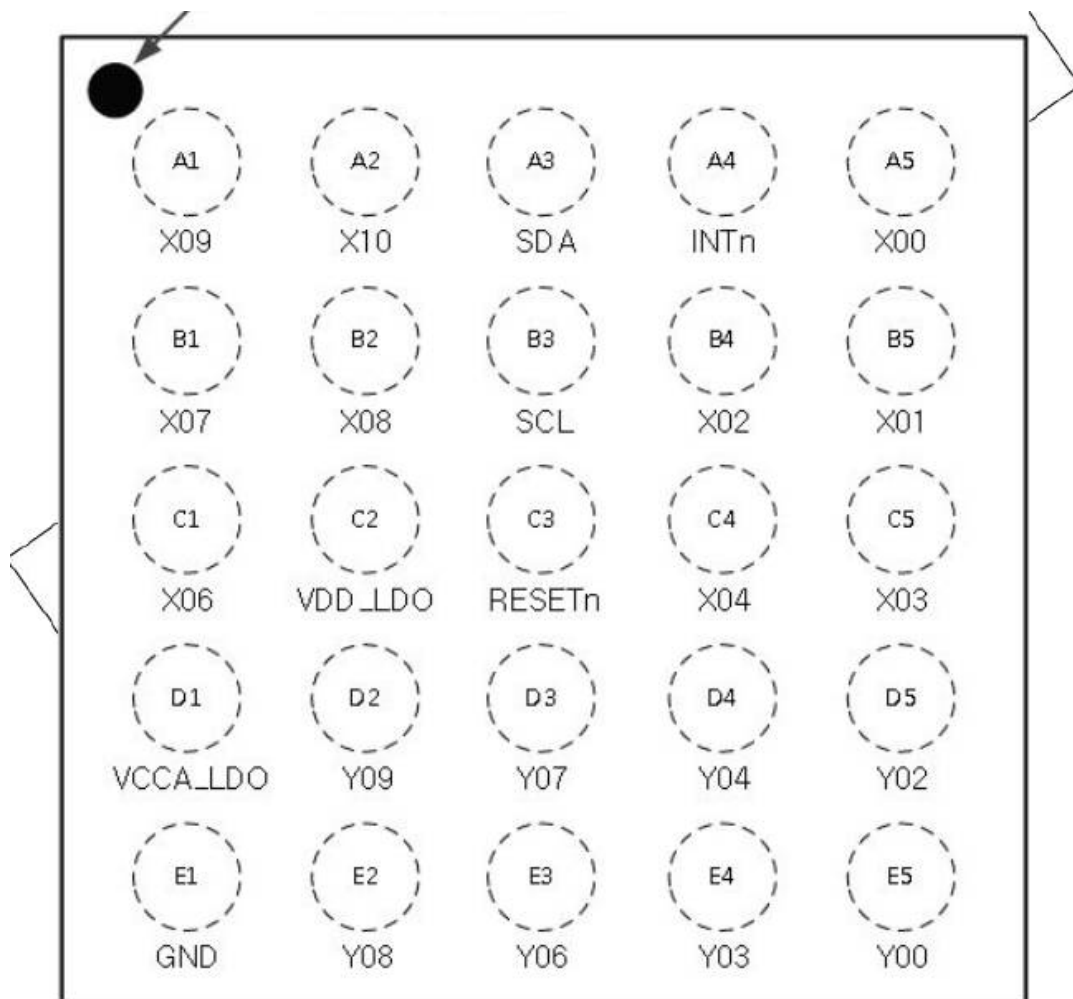

25 Ball WLCSP (TOP VIEW) assignments

5.3 I/O Connection and Block Diagrams

5.3.1 I/O Connection

#	Pin_name	I/O	Description
1	GND1	Power	The power ground

2	X00	IO	Touch Panel trace
3	Y00	IO	Touch Panel trace
4	X01	IO	Touch Panel trace
5	X02	IO	Touch Panel trace
6	Y02	IO	Touch Panel trace
7	X03	IO	Touch Panel trace
8	GND2	Power	The power ground
9	KEY_R	-	Connect to KEY
10	KEY_L	-	Connect to KEY
11	VDDIO	Power	Driver IC digital I/O supply
12	VCI	Power	Driver IC analog supply
13	TE	O	Tear effect output
14	SWIRE	O	Swire protocol setting pin of Power IC
15	GND3	Power	The power ground
16	ID_L	O	Panel ID pin
17	SDI	I	Serial input signal in SPI I/F. The data is input on the rising edge of the SCL signal.
18	CSX	I	Chip select input pin ("Low" enable)
19	SDO	O	Serial output signal in SPI I/F. The data is output on the rising/falling edge of the SCL signal.
20	D/CX	I	Display data / command selection in 80-series MPU I/F and 4-wire SPI I/F. D/CX = "0" : Command D/CX = "1" : Display data or Parameter
21	GND4	Power	The power ground
22	XRES	I	This signal will reset the device and must be applied to properly initialize the chip. Signal is active low.
23	SCL	I	A synchronous clock signal in SPI I/F.
24	GND5	Power	The power ground
25	NC2	-	No Connection
26	MTP	Power	Power supply for OTP. Leave the pin to open when not in use.
27	ELVSS2	Power	AMOLED power Negative
28	ELVDD	Power	AMOLED power Positive
29	ELVSS3	Power	AMOLED power Negative
30	ELVDD	Power	AMOLED power Positive

5.4 Recommended Operating Sequence

5.4.1 Power on sequence

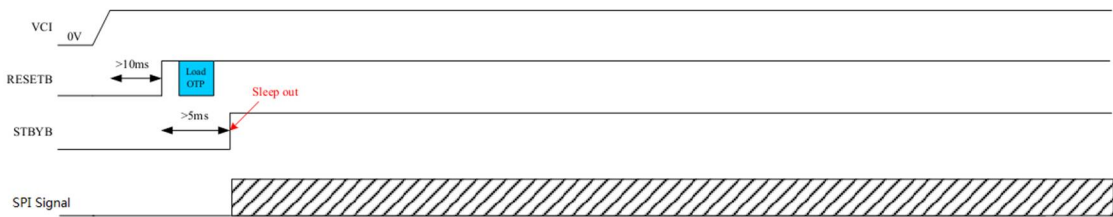

5.4.2

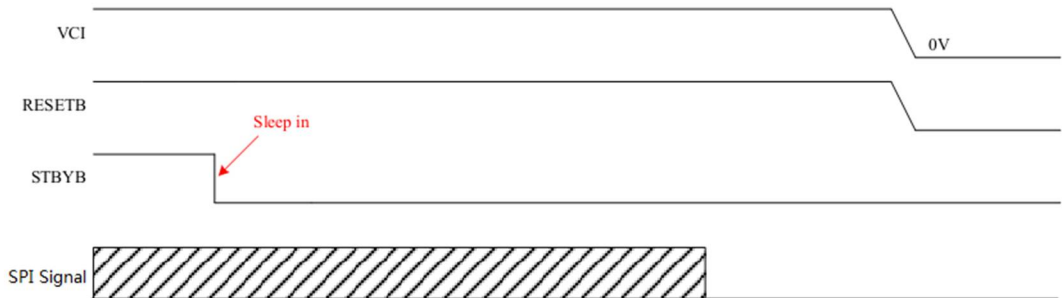

5.4.3 Timing requirements for RESETB

When RESETB of the reset pin equals to Low, it will be in the condition of reset.

When it is in the condition of reset, it will make the device recover the initial set.

However, in order to avoid the reset noise cause reset, there is a mechanism to judge about whether the reset is needed or not.

The closed interval of Low can be shown as the following.

(Test condition: VDDIO=1.65V~3.6V, VSS=0V, TA=-20°C~+70°C)

Parameter	Symbol	Conditions	Spec			Unit
			Min.	Typ.	Max.	
Reset low pulse width	Trst	-	20	-	-	μs

Table: Reset timing

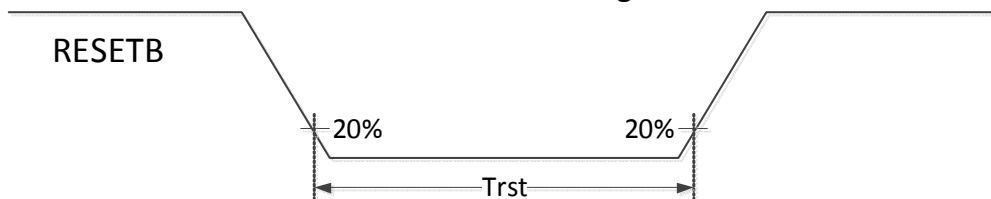

Figure: Reset timing

6 Electro-Optical Specification

Test condition: IOVCC=1.8V, VCI=2.8V, Ta=25°C

Item	Symbol	Condition	Value			Unit	Remark
			Min	Typ	Max		
Luminance		$\theta=0^\circ$	315	350	385	cd/m ²	Note1

Uniformity			$\Phi=0^\circ$	85	90	-	%	Note2
Viewing Angle	Left	θ_L	Cr \geq 200	80	85	-	Deg.	Note3
	Right	θ_R		80	85	-		
	Top	ψ_T		80	85	-		
	Bottom	ψ_B		80	85	-		
Contrast Ratio		CR	$\theta=0^\circ$	10000	100000	-	-	Note4
Response Time		Tr+Tf	$\Phi=0^\circ$	-	2	4	ms	Note5
Color Coordinate of CIE1931	Red	X	$\theta=0^\circ$ $\Phi=0^\circ$	0.63	0.66	0.69	-	
		Y		0.31	0.34	0.37		
	Green	X		0.16	0.21	0.26		
		Y		0.68	0.73	0.78		
	Blue	X		0.09	0.13	0.17		
		Y		0.02	0.06	0.10		
	White	X		0.28	0.30	0.32		
		Y		0.29	0.31	0.33		
NTSC Ratio		NTSC	CIE1931	90	105	-	%	
Flicker		-	-	-	-30	-	dB	Note6
Gamma		-	$\text{Log}(L_v-L_b)=\Upsilon$ $\text{log}(V)+\text{log}(a)$ $V(\text{Gray})=$ 48,72,104,132,164,19 2,224,252,255 $\text{Lum}(\text{gray}255)=300\text{nit}$	2.0	2.2	2.4		
Crosstalk			-	-	-	4	%	Note7
Polarization direction of front polarizer		PdF		--	135	--	deg	Note8
Color temperature		CT		6724	7524	8324	K	
Luminance decrease ratio of full white			$\theta_L=30^\circ$		40	45	%	Note9
			$\theta_R=30^\circ$		40	45	%	
			$\psi_T=30^\circ$		40	45	%	
			$\psi_B=30^\circ$		40	45	%	
Color shift			@30°	---	4	5	JNCD	Note10
OLED lifetime		0.95*(TYP brightness)	At 25°C, with white color pattern	100			hrs	
Image retention			To check image retention, a 4x6 Chess Pattern shall be displayed for 30 sec. and do the judgment after switching the pattern to L186 Gray Level.			2	sec.	ND02 invisible

Note1: Environmental conditions

Temp. 25°C ± 3°C, 65 ± 20%RH, Dark Room.

Distance of OLED display center to measuring machine is 50cm.

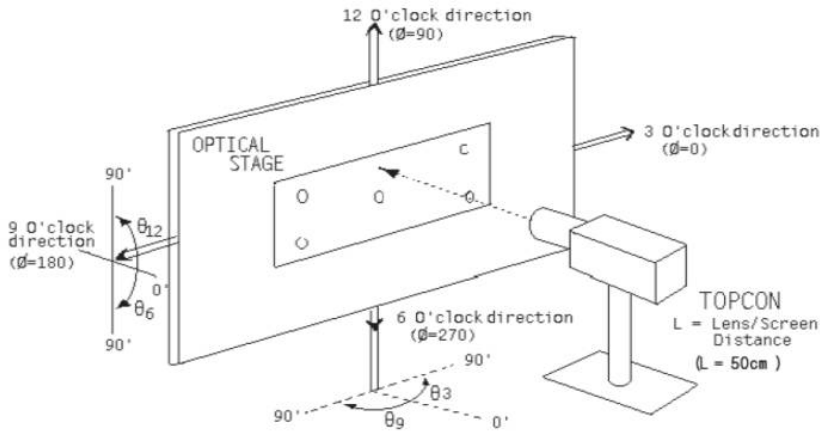

Note2: Brightness Uniformity definition

Measure 5 points of Display Brightness,

$$\text{Brightness Uniformity} = L_{\min} / L_{\max} \times 100\%$$

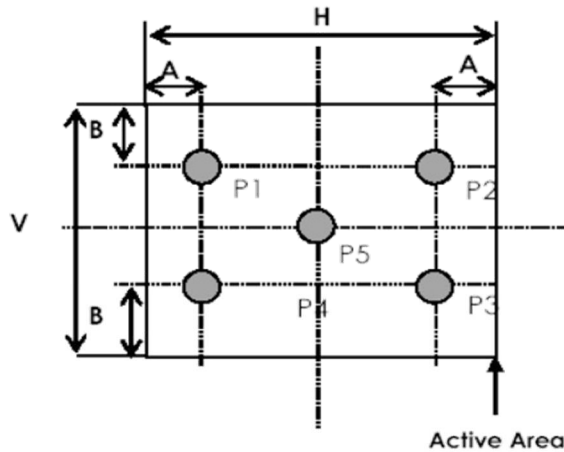

A: 1/4H

B: 1/4V

H.V: Active Area

Note3: The definition of Viewing Angle

Refer to the graph below marked by θ and Φ

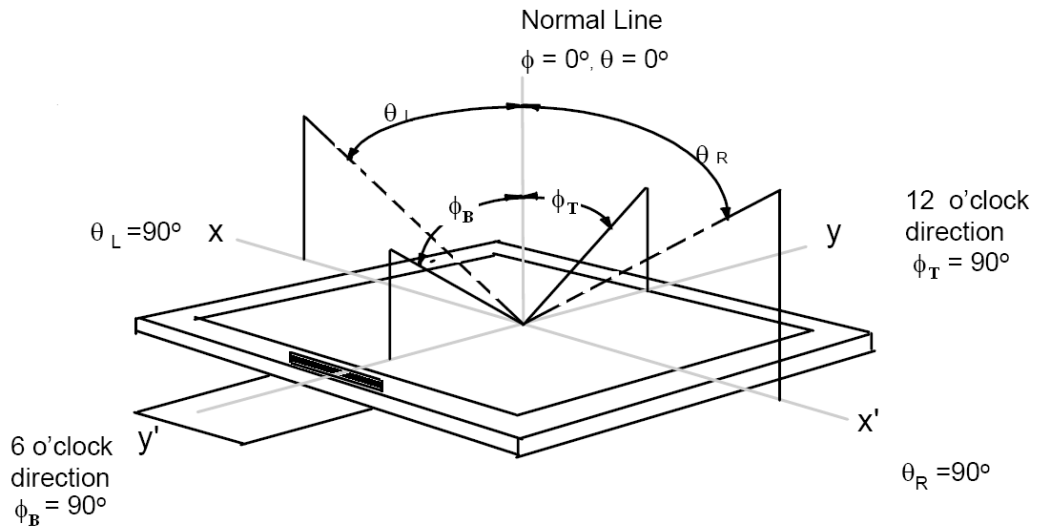

Note4: Contrast Ratio

Dark Room C.R=LW/LB

LW: full white brightness of display center P0;

LB: full black brightness of display center P0.

Note5: Response Time

Response time=Pixel turn on and turn off time (White<=>Black).

It is measuring transition time from 10% to 90% of luminance.

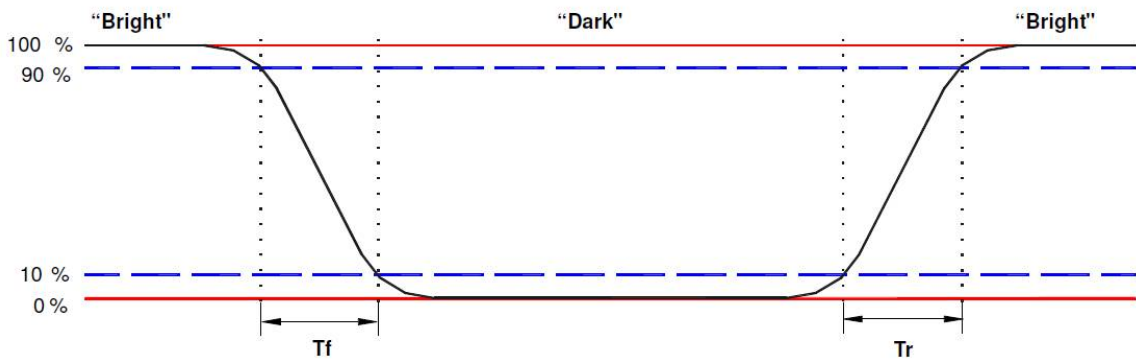

Note6: Flicker

Suggested Instruments: **Konica Minolta CA-310** or **Klein Instruments K-8**

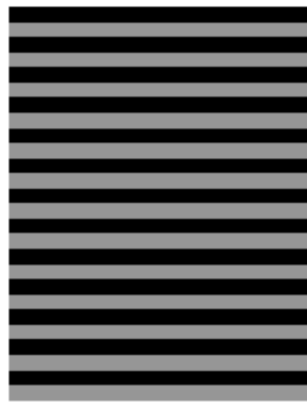

Odd row : L0 Black
Even row : L186 gray level

Flicker Test Pattern

The flicker level is defined by **Fast Fourier Transformation (FFT)** as follows:

$$Flicker = 20 \log_{10} \left(2 \frac{f_{FFT}(n)}{f_{FFT}(0)} \right) + FS(Hz) \quad (dB)$$

Where

$f_{FFT}(n)$ is the n-th FFT coefficient.

$f_{FFT}(0)$ is the 0-th FFT coefficient which is DC component.

$FS(Hz)$ is the flicker sensitivity as a function of frequency.

The peak flicker level shall be reported based on the calculation using above formula in which $FS(Hz)$ is determined by the flicker weighing factor shown below.

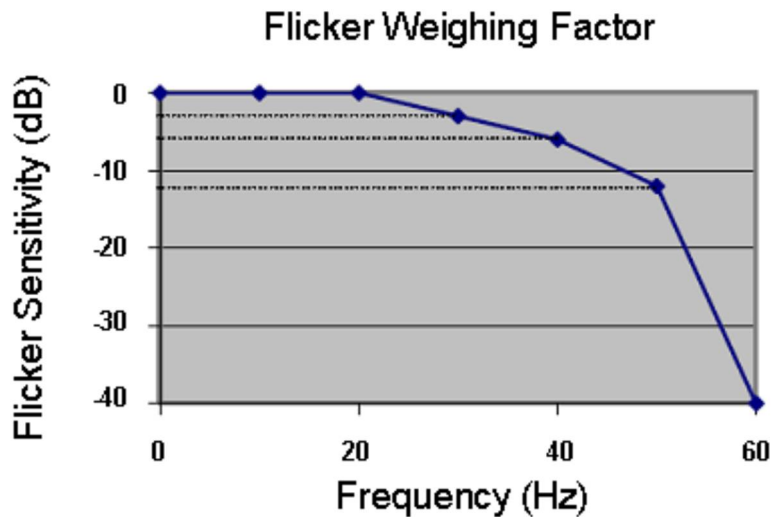

Note7: Crosstalk

Crosstalk shall be calculated by the luminance of **B1~B4** and **G1~G4** in the patterns shown below.

Box Pattern: **L128** gray level background with a **L255** White window in the central area.

Gray Pattern: **L128** gray level background only.

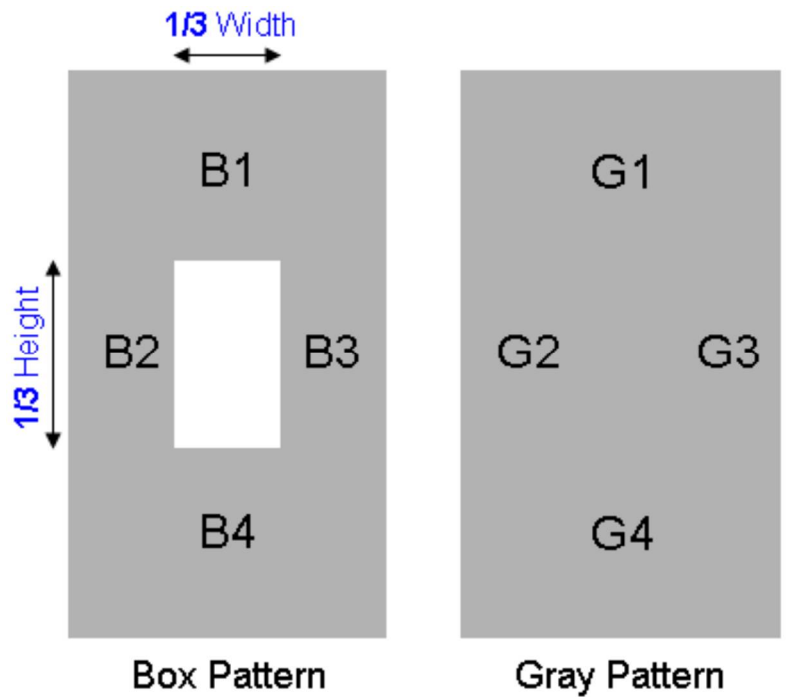

Crosstalk

$$\equiv \text{Maximum: } \left\{ \frac{|B1 - G1|}{G1}, \frac{|B2 - G2|}{G2}, \frac{|B3 - G3|}{G3}, \frac{|B4 - G4|}{G4} \right\} \times 100\%$$

Note8: Polarization Direction Definition

Viewing direction is normal user viewing direction which is vertical to the display surface

The polarizer which is closer to viewer is defined as Front Polarizer

The X axis is defined as parallel line to top & bottom sidelines of the Active Area

PdF which is marked in blue arrow is polarization degree of Front polarizer

The polarization degree parameter must be indicated in range of 0deg to 180deg according to above definition

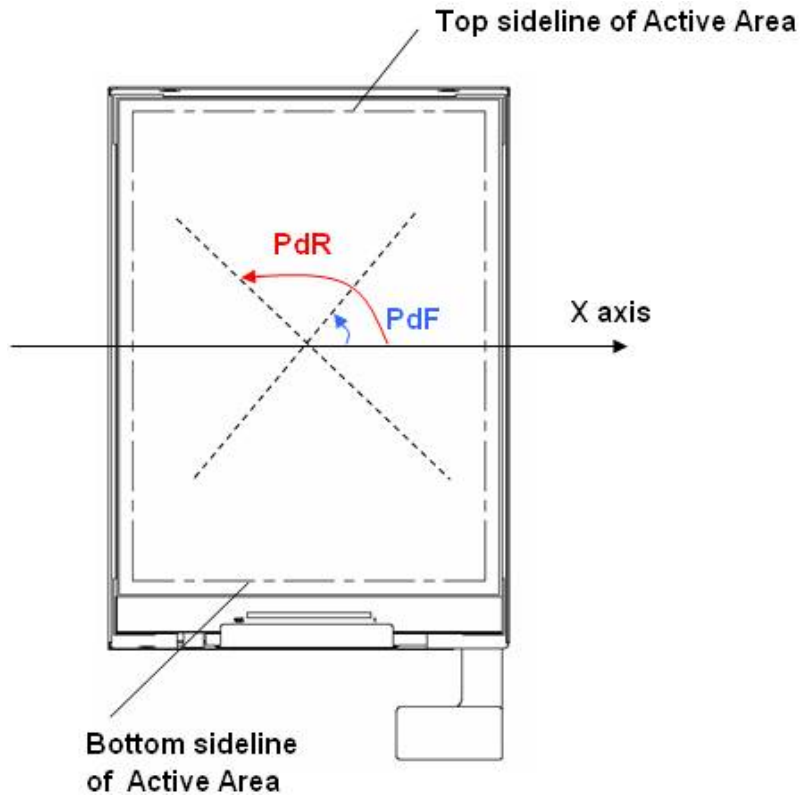

Note9: Definition of Luminance decrease ratio

Refer to the graph of note 3

Test pattern: Full White

The luminance decrease ratio is calculated by using following formula:

$$\text{Luminance decrease ration} = 1 - \frac{\text{Luminance test at left, right, top, bottom} = 30^\circ}{\text{Luminance test at left, right, top, bottom} = 0^\circ}$$

Note10: Color Shift JNCD

For JNCD measure:

Test pattern: Full White

On the condition $\theta=0$ $F=0^\circ$, we can get the color coordinate (u_1', v_1') and on 30° we can get another color coordinate (u_2', v_2')

$$\text{Delta} = \text{Square Root}((u_2' - u_1')^2 + (v_2' - v_1')^2)$$

JNCD stands for "Just Noticeable Color Difference"

For the (u', v') color space JNCD=0.0040.

2JNCD means $\text{Delta } u'v' < 0.0080$

This Requirement is from our customer and we have test some of our phone display and the result is OK.

7 Reliability

7.1 Environmental Test

Item	Main spec	No. of failures / No. of examinations
High Temperature Operation	70°C / 128hrs	0/5
Low Temperature Operation	-20°C / 128hrs	0/5
High Temperature Storage	80°C / 128hrs	0/5
Low Temperature Storage	-40°C / 128hrs	0/5
High Temperature Humidity Operation	60°C/93%RH/ 128hrs	0/10
Thermal Shock	-40°C~80°C dwell time=0.5hr, 50 cycles.	0/10

7.2 Electrical Test

Item	Main spec	Note
Air Discharge	±2kV , 150pF/330Ω (Module level, without CG)	5Points, Each 10times. After one time discharge, touch the ground for 1s. No degradation of OLED performance after this test.
Contact Discharge	±2kV, 150pF/330Ω (Module level, without CG)	

7.3 Mechanical Test

Test item	Test condition	Note
Packing vibration-proof test	2g, f=10->55->10Hz apply in each of X, Y, and Z direction for 30 min	Package
Packing Drop test	Drop the packing from 60cm height, 6-faces, 3-edges and 1-corner(one time for each)	Package

8 Outline Dimension Drawing

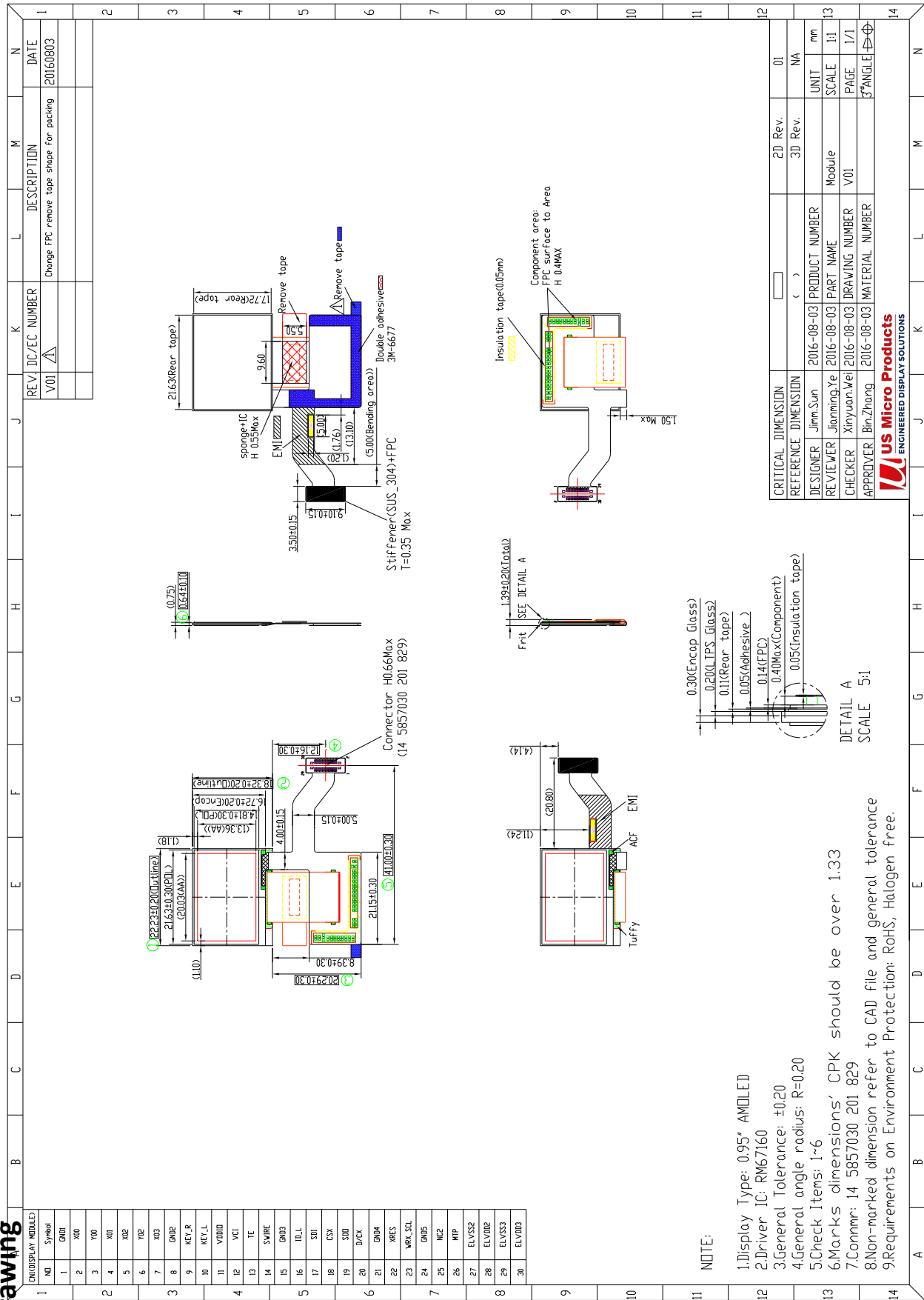

9 Packing Specification

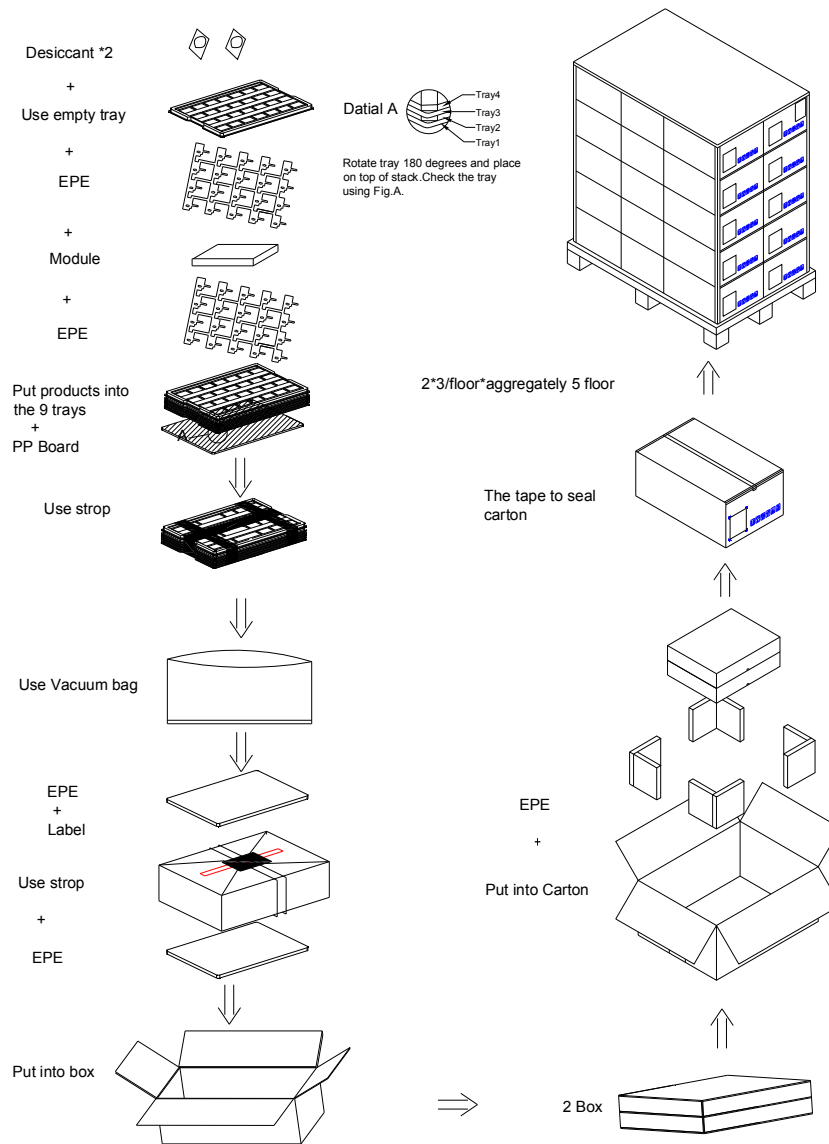

1) 内包装

NO	Item	材质	尺寸	数量	模组数量	备注
1	纸盒	纸	459*294*115mm	2	180 pcs /纸盒	
2	吸塑盒	PET	455*290	20	下面9层, 20 pcs /吸塑, 最上面的吸塑为空	10吸塑/盒
4	防尘袋	Al	660*440*0.28mm	2	/	
5	珍珠棉	EPE	394.3*228.23*0.1mm	40	2/吸塑盘	
6	内盒标签	PET	52*100*0.075mm	2	/	

2) 外包装

NO	Item	材质	尺寸	数量	模组数量	备注
1	外箱	纸	516*338*248mm	1	360pcs OLED/箱	
2	外箱标签	贴纸	52*100*0.1mm	1	/	